

NÁVOD / INSTRUCTION

1/48

CZ - Historie

Pfalz Flugzeugwerke GmbH byla založena v roce 1913 ve Speyeru v tehdejší Bavorském království Alfred Eversbuschem, jeho bratrem Ernstem a dalšími investory. Dne 12. července 1913 byla společnost zapsána v obchodním rejstříku. Projekt byl financován bavorskou vládou.

Nová továrna zahájila licenční výrobu dvouplošníků Otto, ale hlavně zakoupila těsně před válkou licenci na výrobu typů Morane Saulnier typ L (dvoumístný hornoplošník typu parasol) a typ H (jednomístný střednoplošník). Ten byl označen jako Pfalz E.I. Poháněl ho motor Oberursel U0 o výkonu 80 koní. Přednostně byl dodáván bavorským jednotkám. Před vyzbrojením kulomety se Pfalzy E.I užívaly jako rychlé průzkumné stroje. Po vybavení Pfalzů E.I kulomety se synchronizačním zařízením se z nich staly, společně s Fokkery E.I, první opravdové stíhačky německého letectva. Montován byl kulomet LMG 08/15 na pravou stranu přídě. Používaly se hlavně jako doprovodné stíhací stroje k ochraně průzkumných letounů, jak na východní, tak západní frontě. Několik strojů bylo nasazeno i v Palestině. Nejvíce strojů bylo na frontě v dubnu 1916. Po tomto datu jejich počty na frontě klesaly. Jednak je nahrazovaly výkonnější Pfalzy verze E.II a hlavně také další varianty úspěšnější varianty Fokkerů E.II a E.III.

rozpětí: 9,26 m, délka: 6,30 m, max. rychlost: 140 km/h, vytrvalost: 1,5 hodiny, výstup do 3000 m: 8 min.

EN - History

Pfalz Flugzeugwerke GmbH was established in Speyer in the then Kingdom of Bavaria in 1913 by Alfred Eversbusch, his brother Ernst and several other investors. The company, funded by the Bavarian Government, was registered on July 12, 1913.

The first types to be produced by the new company were licence-built Otto biplanes, but production rights for Morane Saulnier monoplanes were bought before the Great War, namely the Type L parasol-wing two-seat monoplane and Type H mid wing single seater. The latter was built as the Pfalz E.I, fitted with an 80HP Oberursel U0 engine. These aircraft were, in the first place, delivered to Bavarian units. At first without armament and were used as fast scout planes, later after being equipped with machine gun armament with synchronization gear, they became, along with the Fokker E.I, the first true fighter planes of the German military. The armament of one LMG 08/15 machine gun was mounted on the right side of the front fuselage and the machines were used to escort and protect reconnaissance aircraft both on the Eastern and Western Front, smaller number of them also saw service in Palestina.

The greatest number of the Pfalz fighter plane was used operationally during April 1916, later their numbers decreased and the Pfalz E.I were either replaced by a more modern E.I type or by much more successful Fokker E.II and E.III fighter planes.

Wingspan: 9,26 m, Length: 6,30 m, Max. Speed: 140 km/h, Endurance: 1.5 hrs, Time to 3000 m: 8 min.

PLASTIC PARTS (A/B)

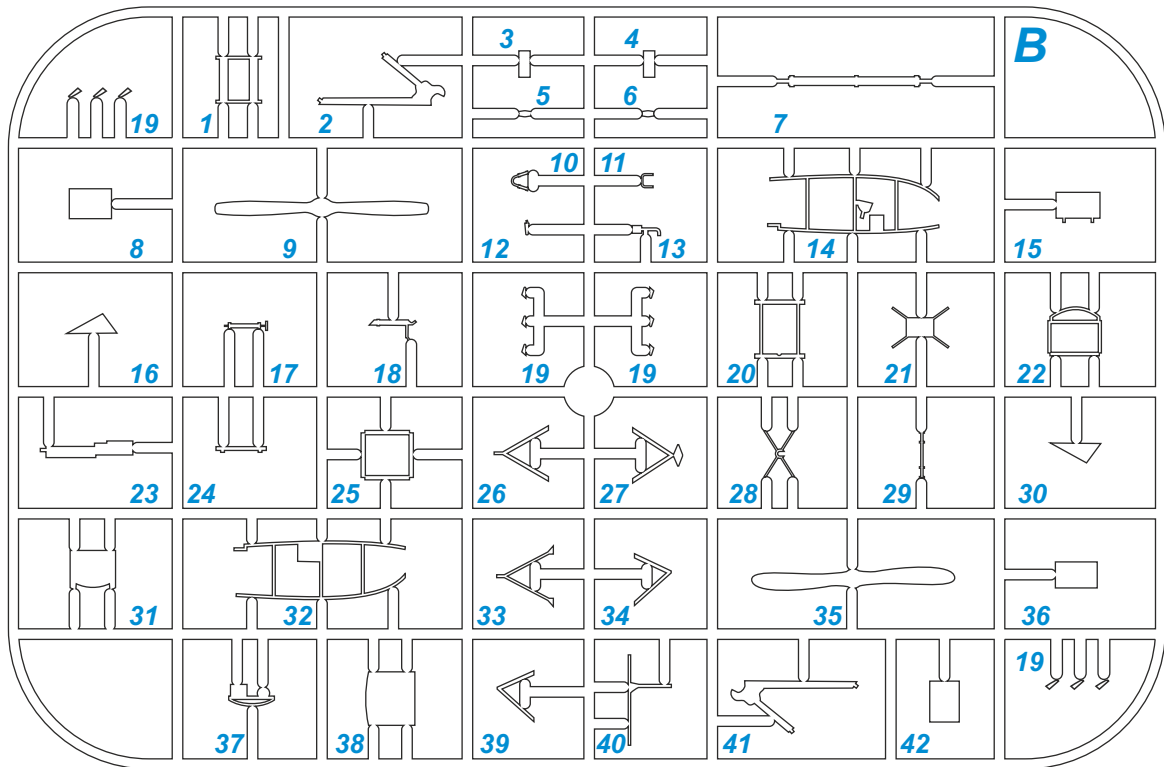
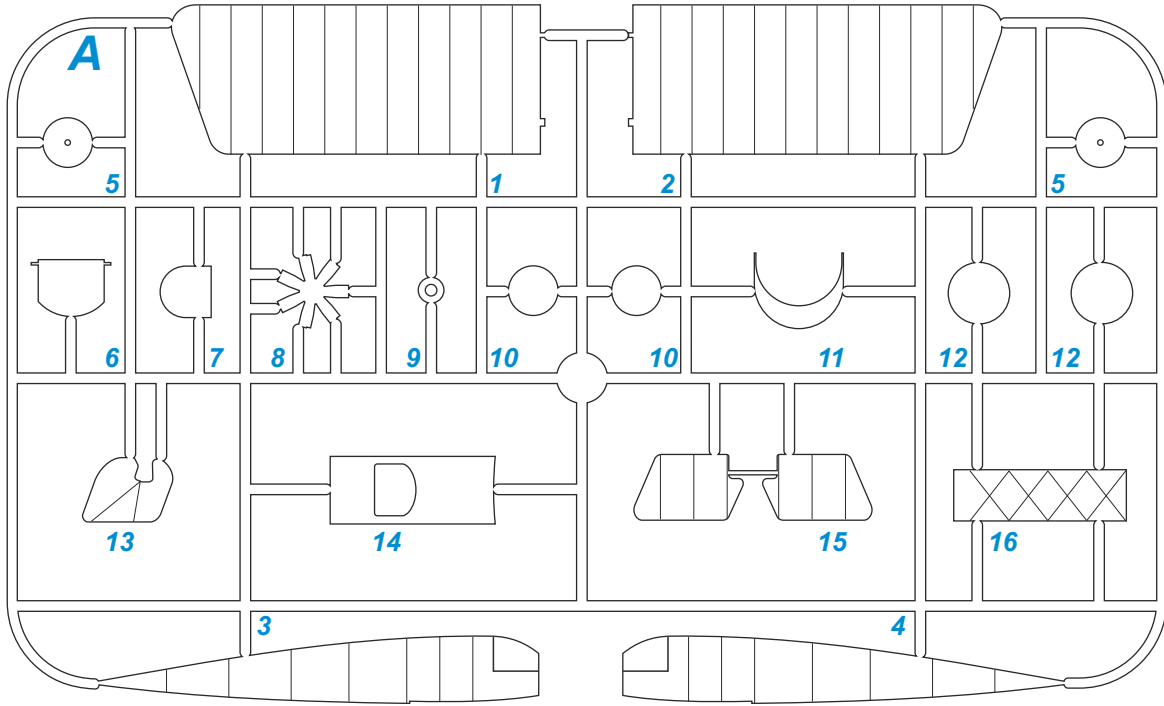

- A** Černá / Black H2 / C2
- B** Barva plátna / Linen H85 / C45
- C** Špinavě bílá / Off White H21 / C69
- D** Dřevo / Wood H37 / C43
- E** Hliník / Aluminium H8 / C8
- F** Tmavý kov / Metal Black H28 / C18
- G** Červenohnědá (kůže) / Red Brown (Leather) H47 / C41

Barvy GUNZE / GUNZE Colour No.

PHOTO-ETCHED PARTS (PE)

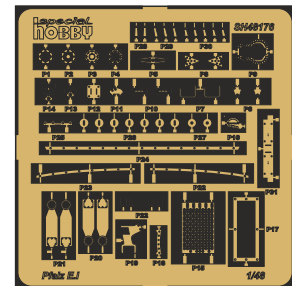

FILM (F)



SYMBOLS

- | | | | | | | |
|--|--|---|--|---|-----------------------------|---|
| <p>MOŽNOST VOLBY OPTIONAL NACH BELIEBEN OPTION</p> | <p>POUŽIT KYANOAKRYLÁTOVÉ LEPIDLO INSTANT CYANOACRYLATE GLUE ZYANOAKRYLÁTKLEBER COLLE CYANOACRYLAT</p> | <p>OHNOUT BEND BIEGEN COURBER</p> | <p>ZHOTOVIT NOVÉ SCRATCH BUILD FERTIGSTELLEN ACHEVER</p> | <p>ŘEZAT/VRTAT CUT OFF/DRILL ENTFERNEN DETACHER</p> | <p>GSI colours code</p> | <p>NATŘÍT COLOUR FARBEN PEINDRE</p> |
|--|--|---|--|---|-----------------------------|---|

1

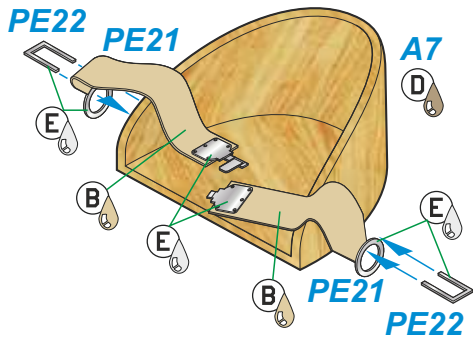

2

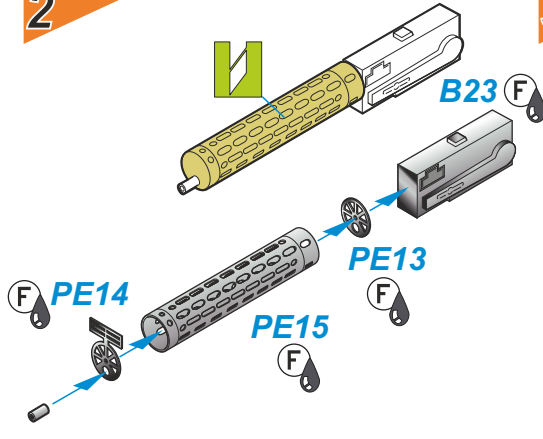

3

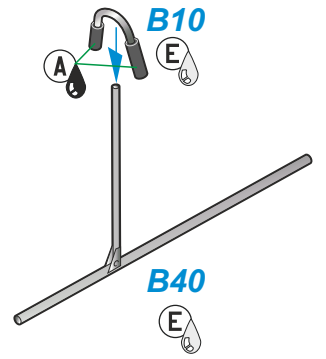

4

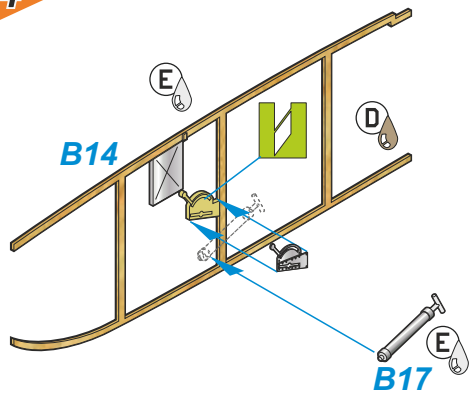

5

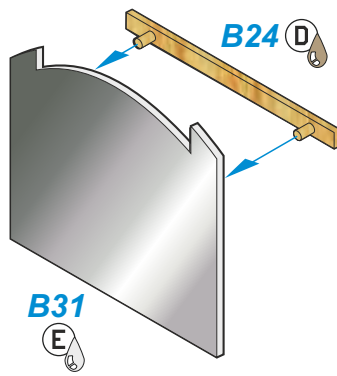

6

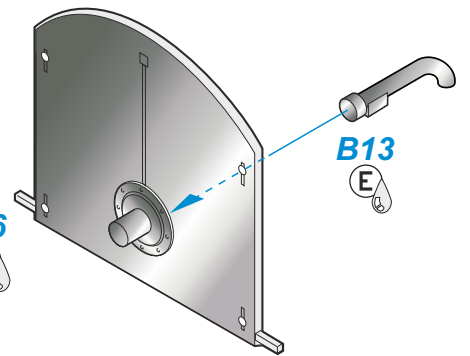

7

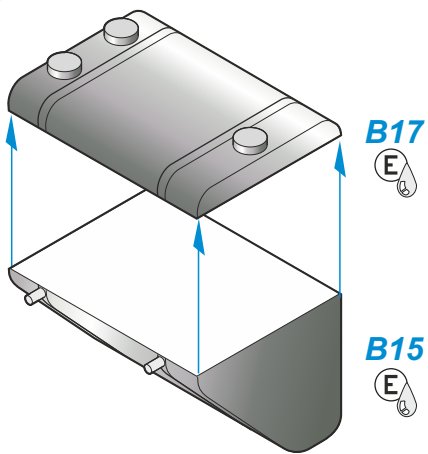

8

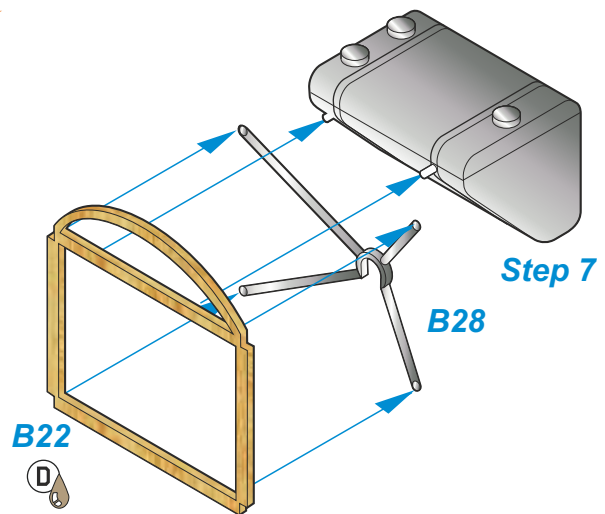

9

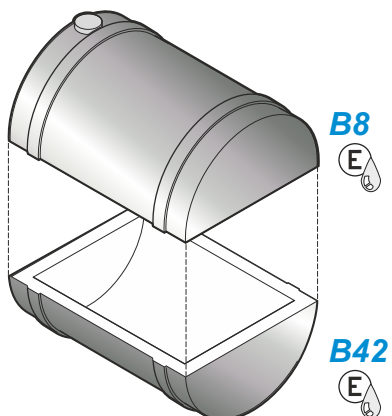

10

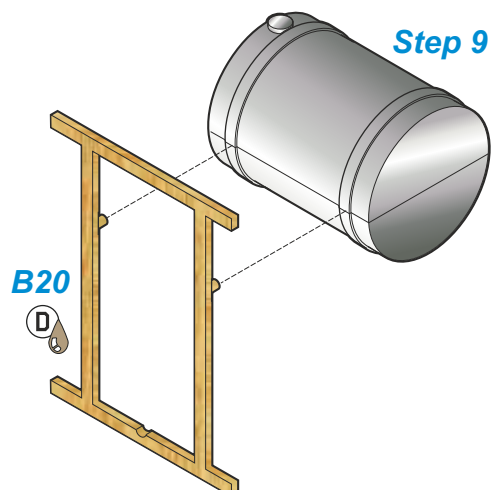

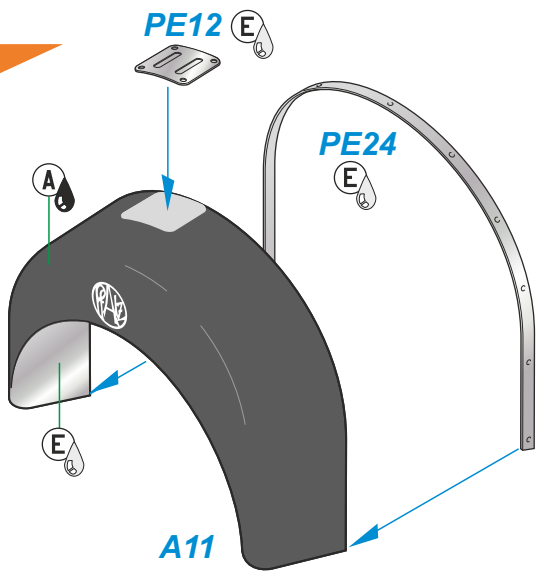
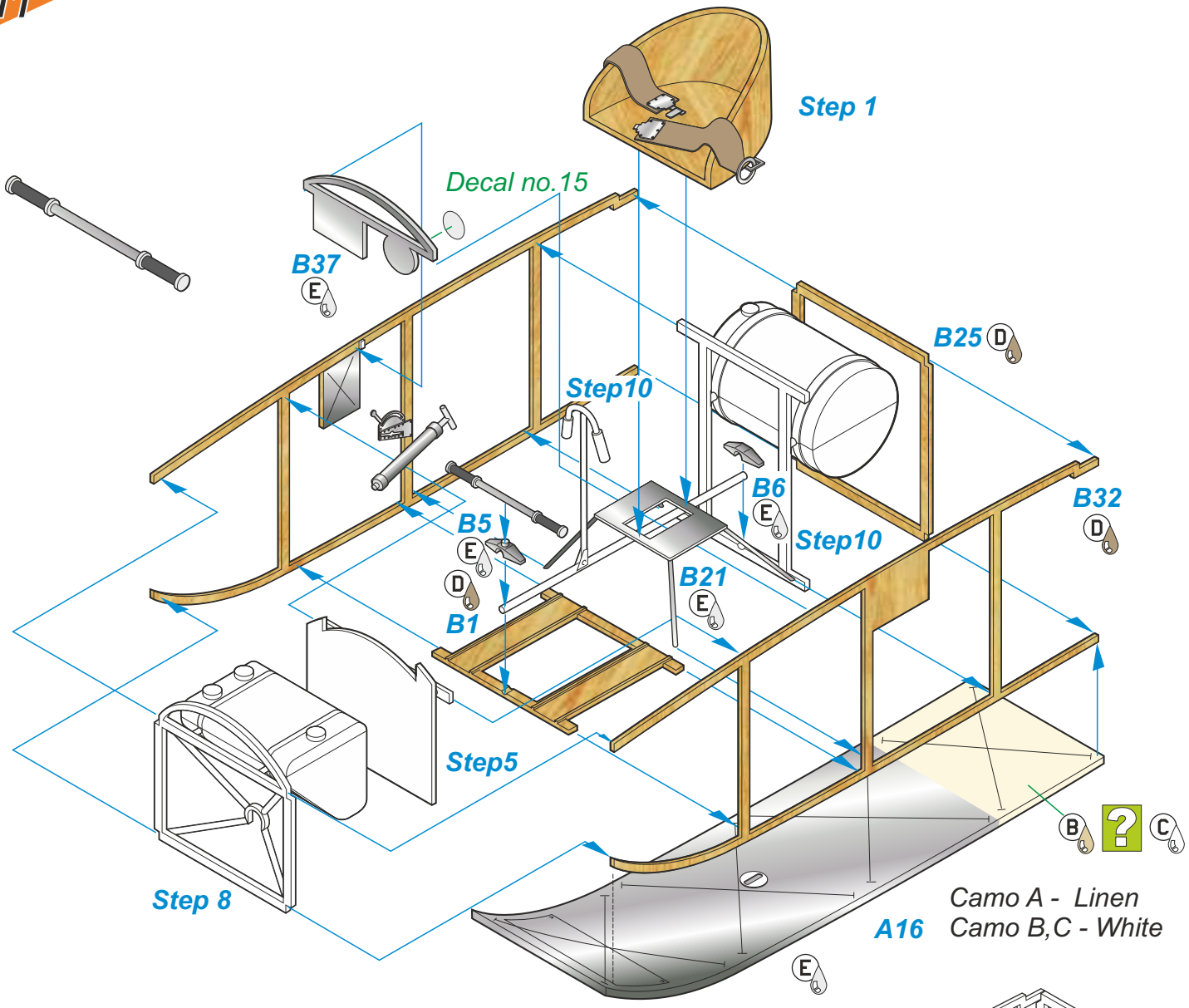

Step 11 info view

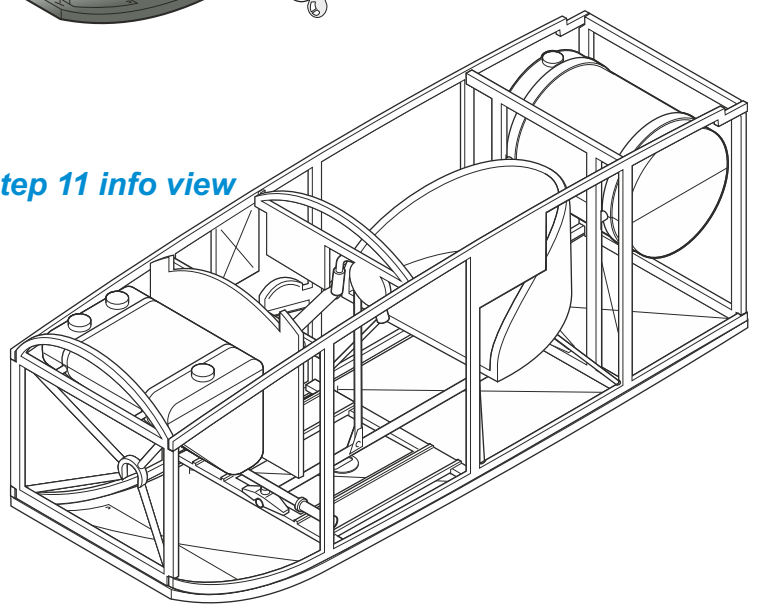

13

2x 

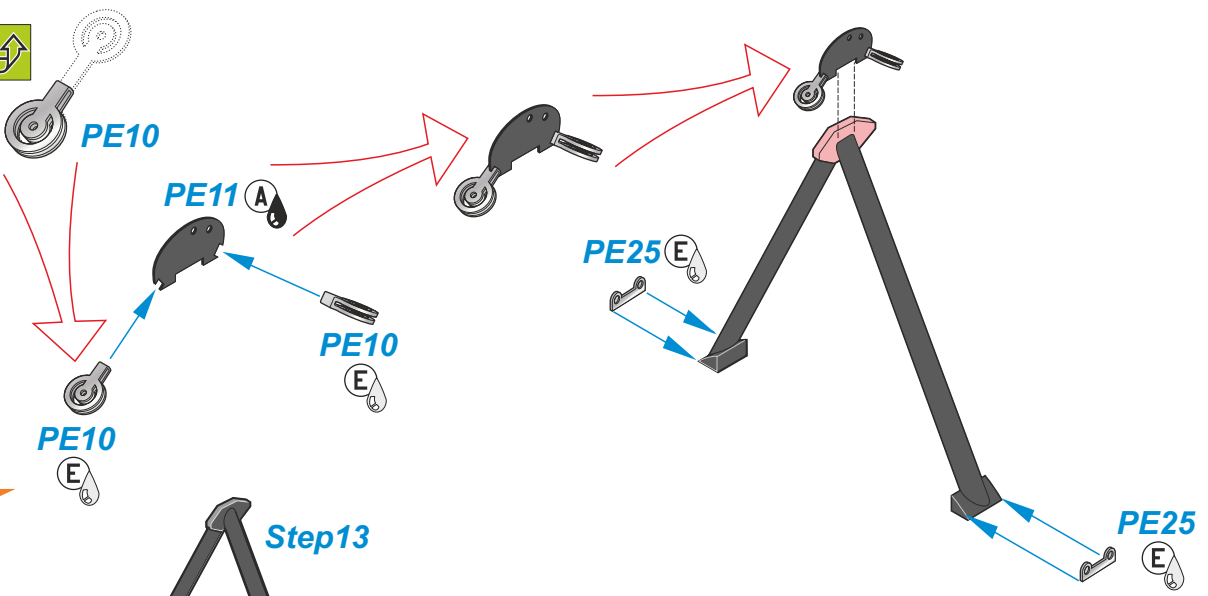

14

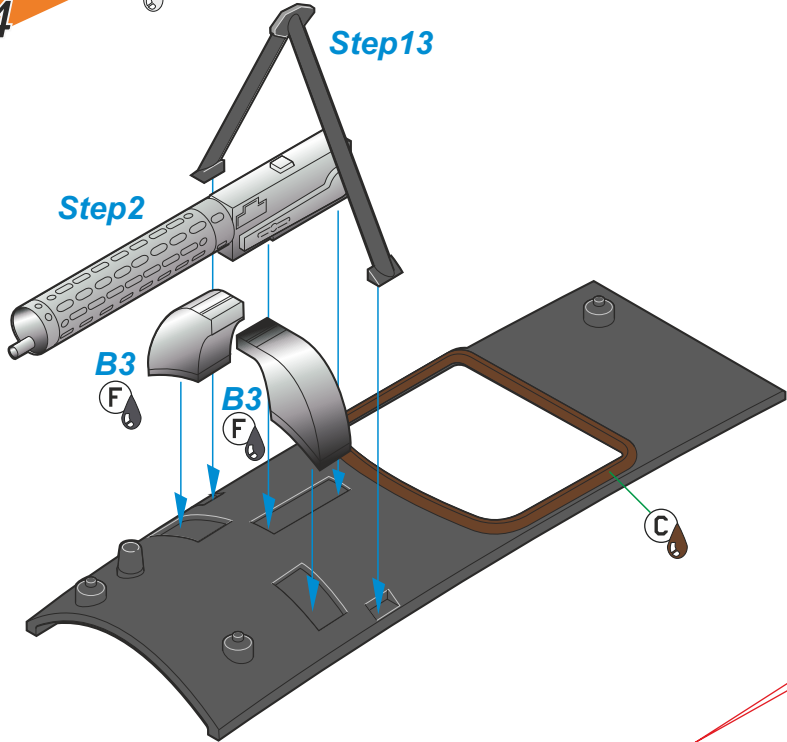

15

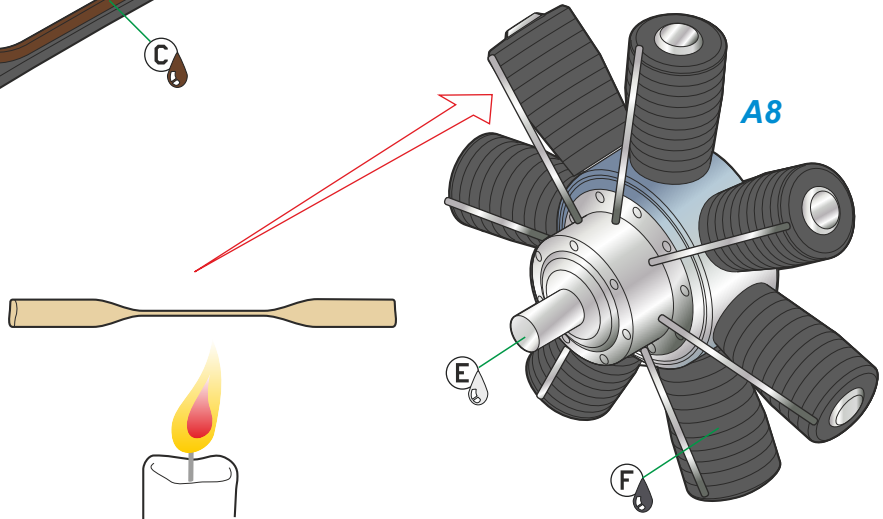

16

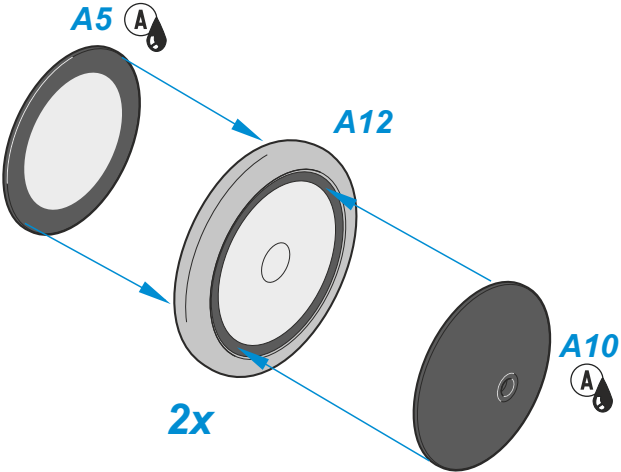

17

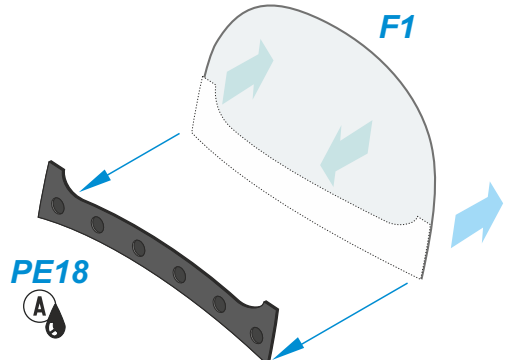

18

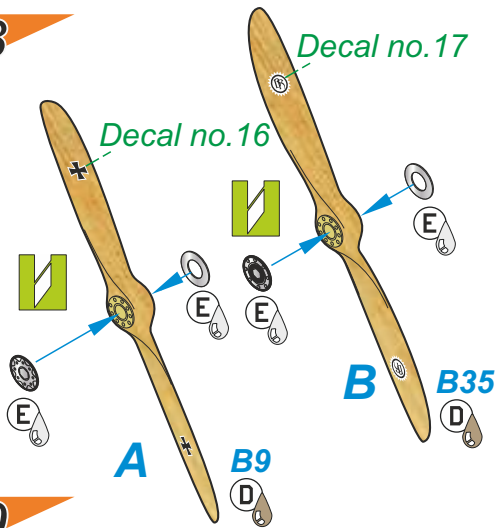

19

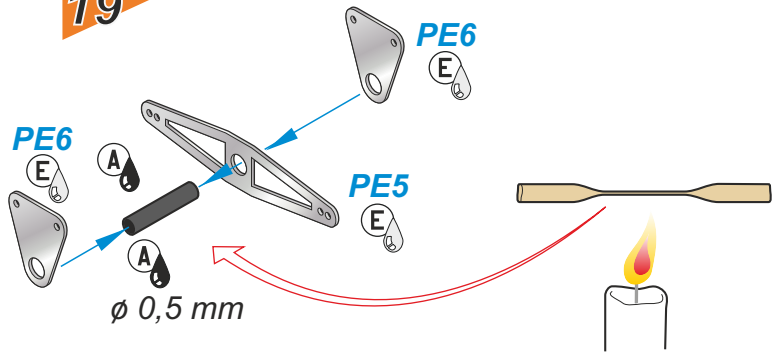

20

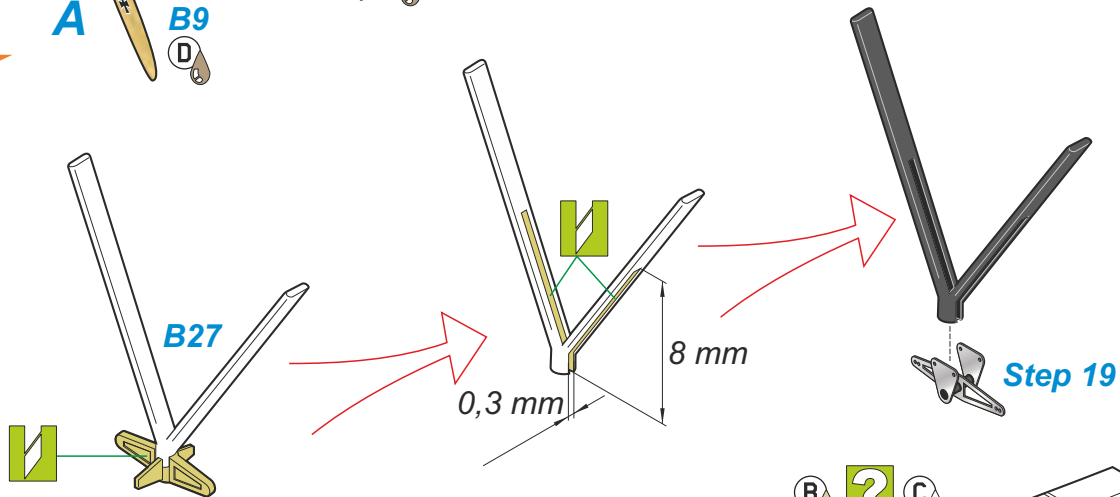

21

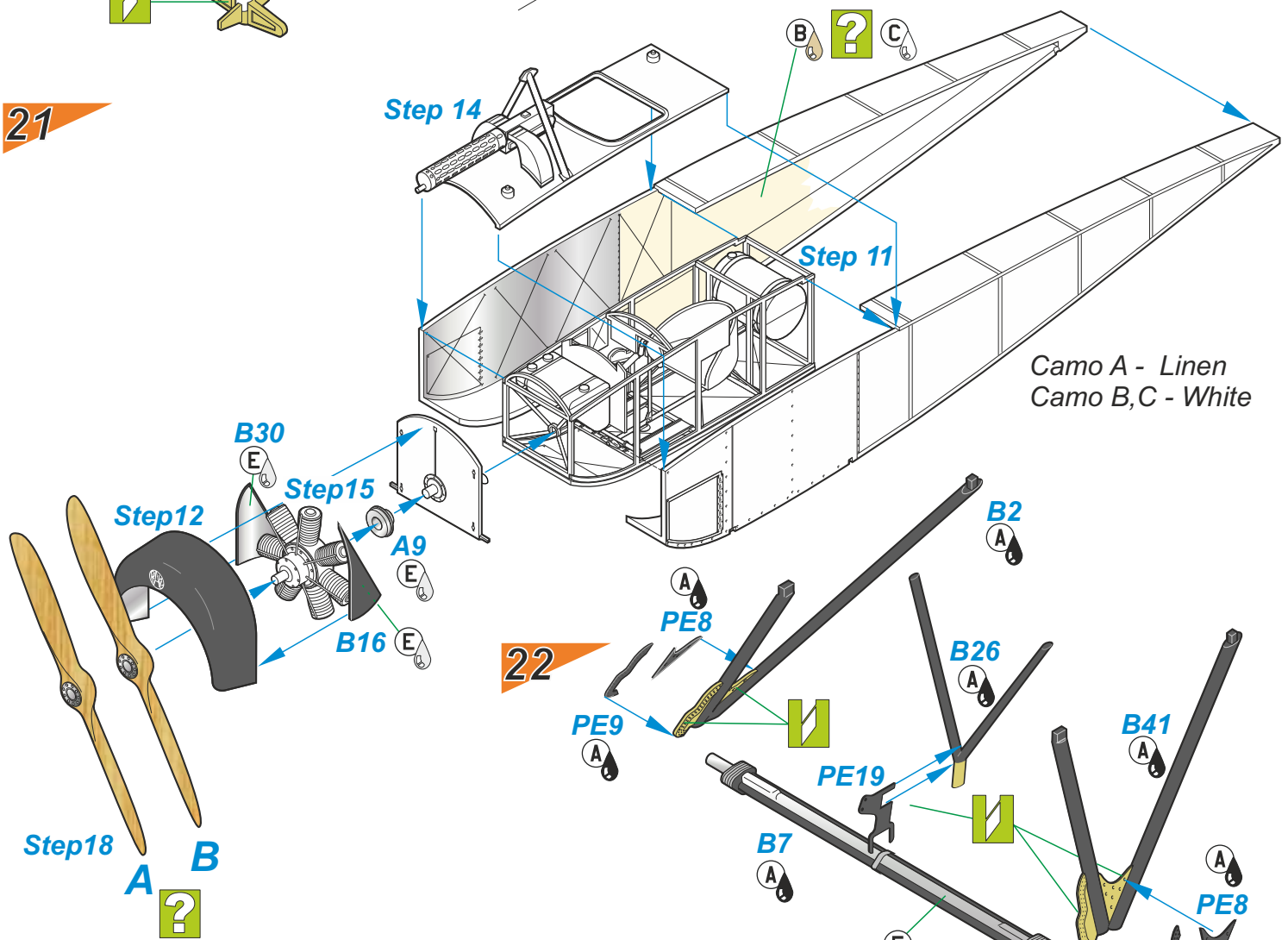

22

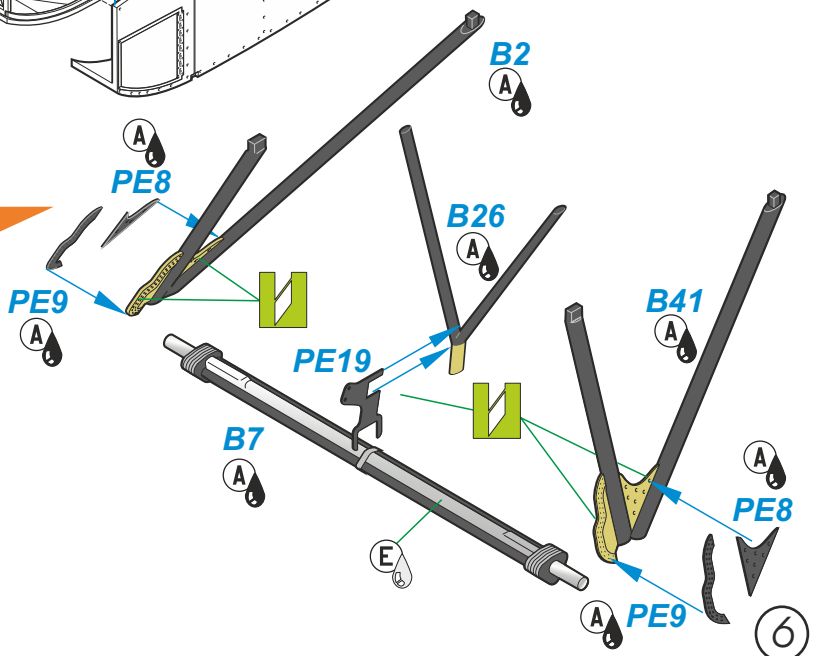

Camo A and B - propeler A only
 Camo C - propeler B only

6

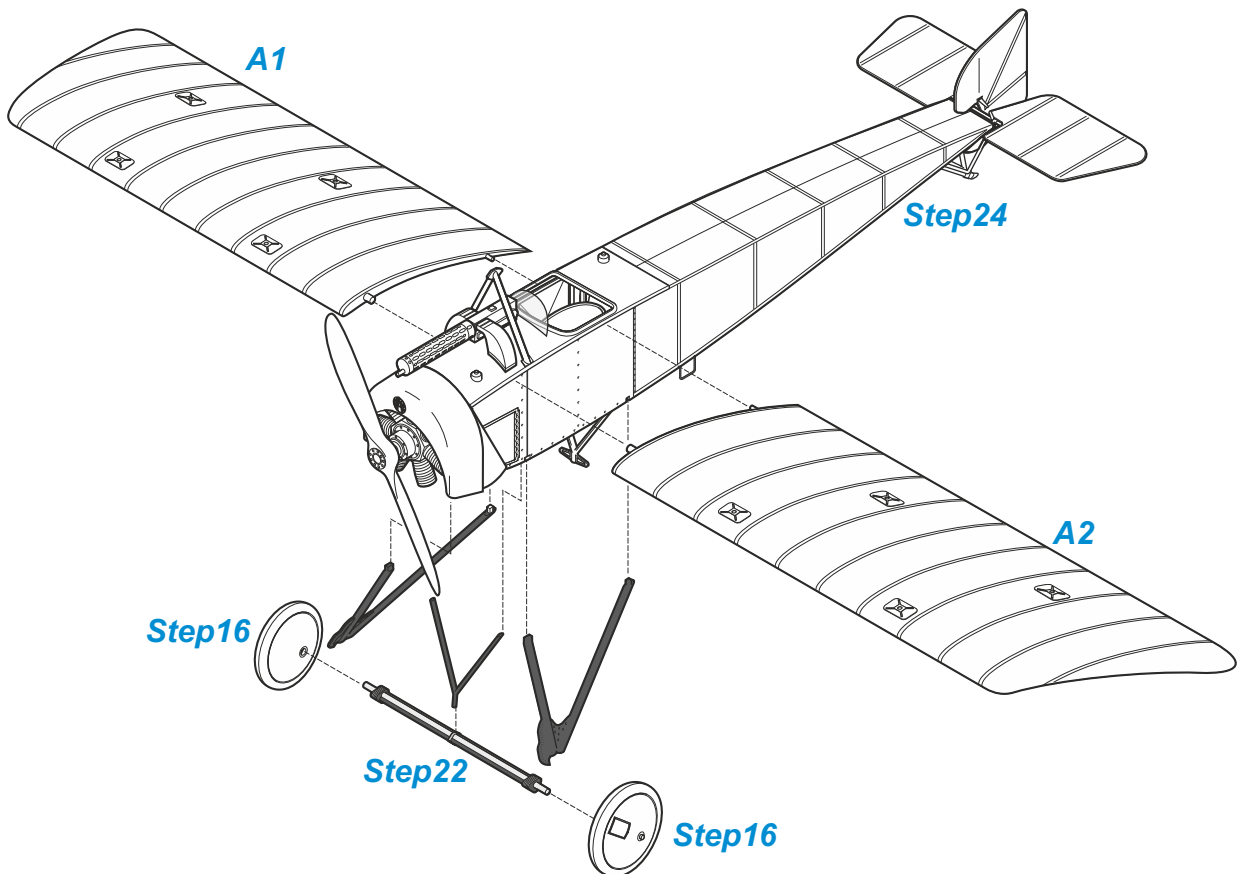
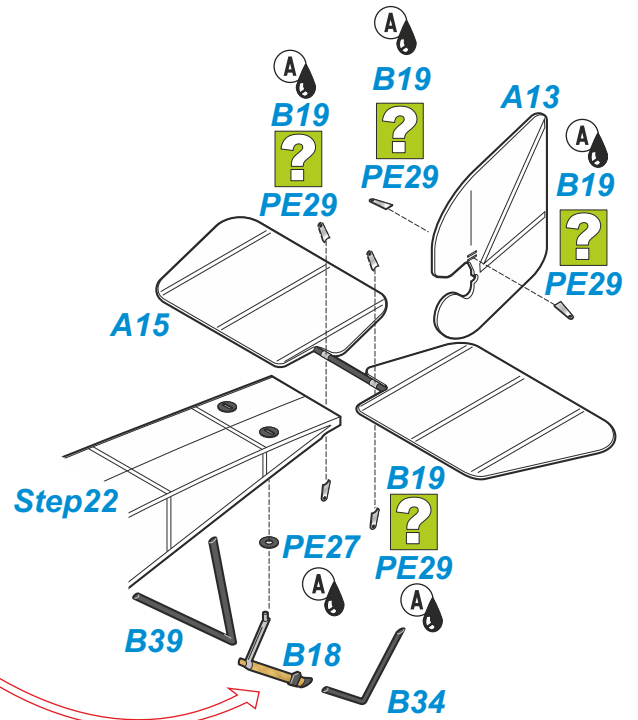
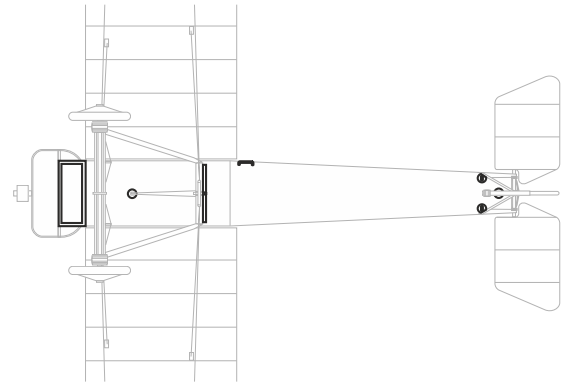
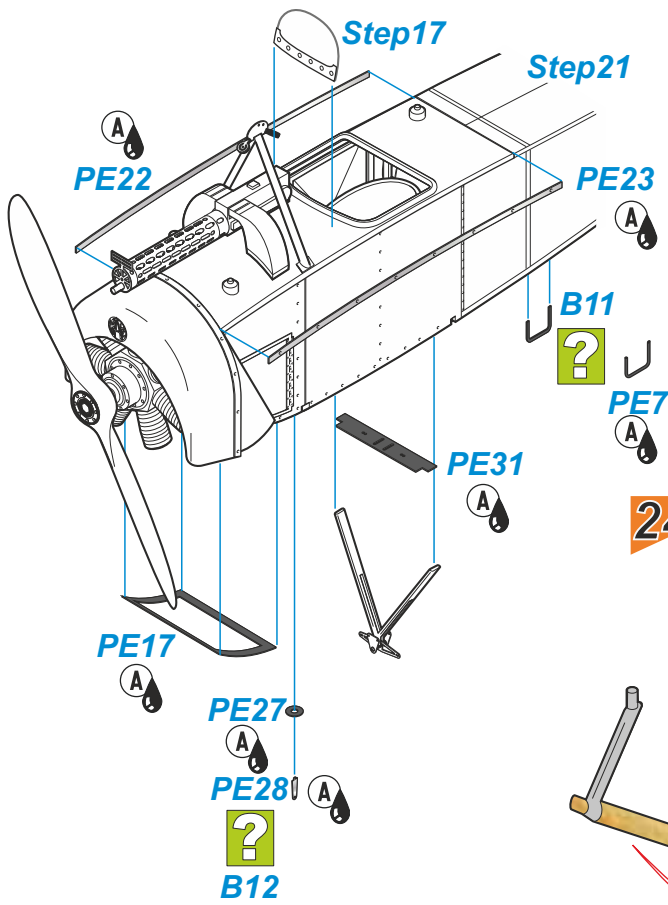

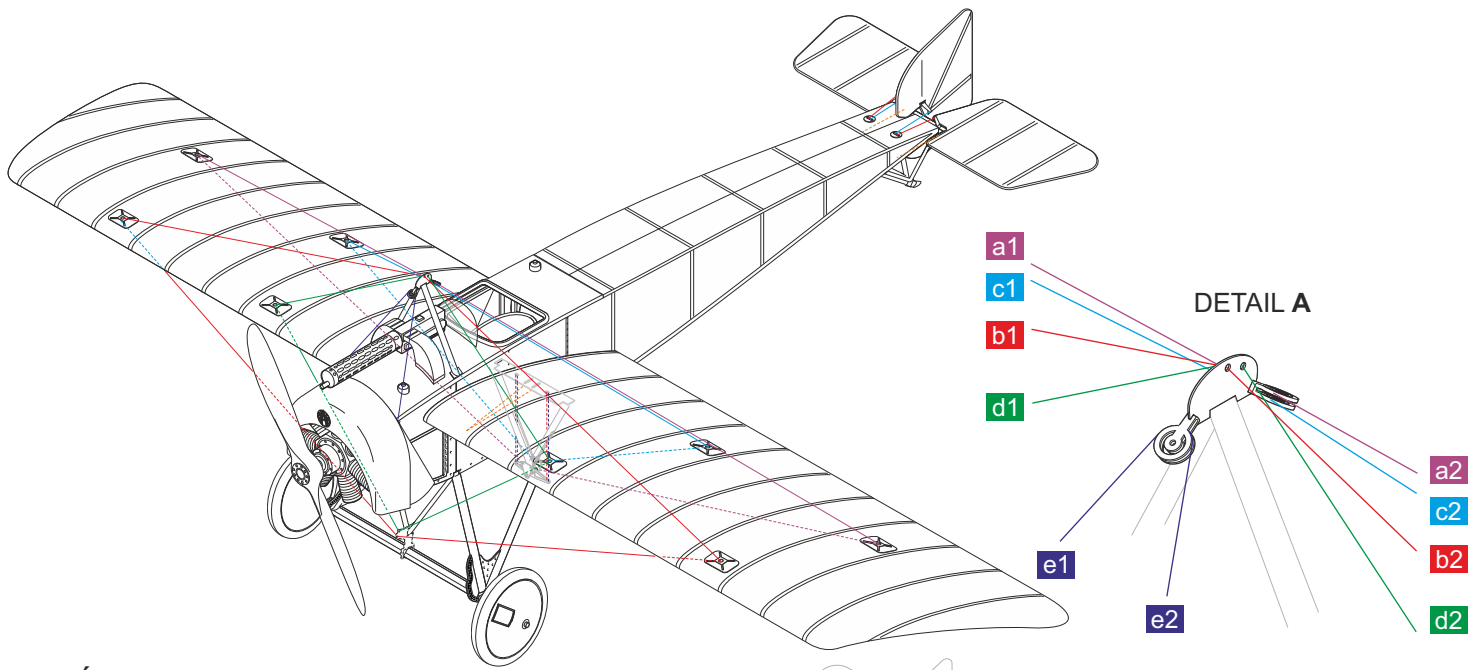

HORNÍ STRANA / UPPER SIDE

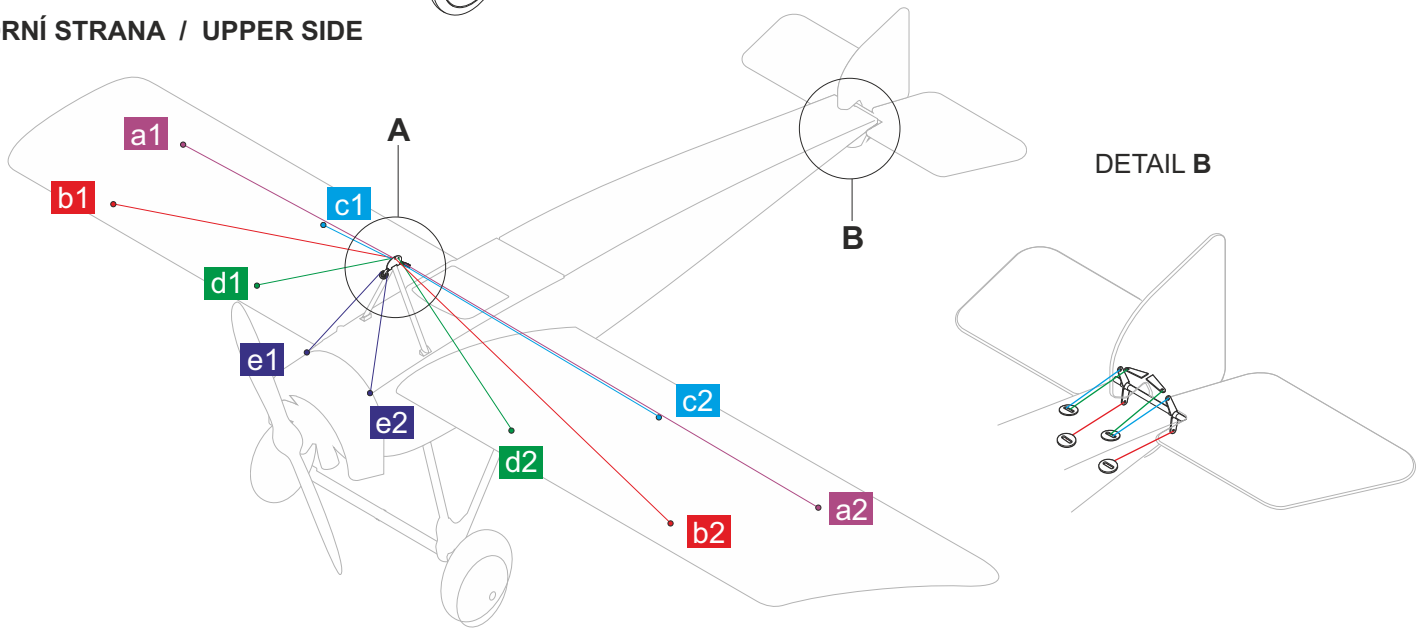

SPODNÍ STRANA / BOTTOM SIDE

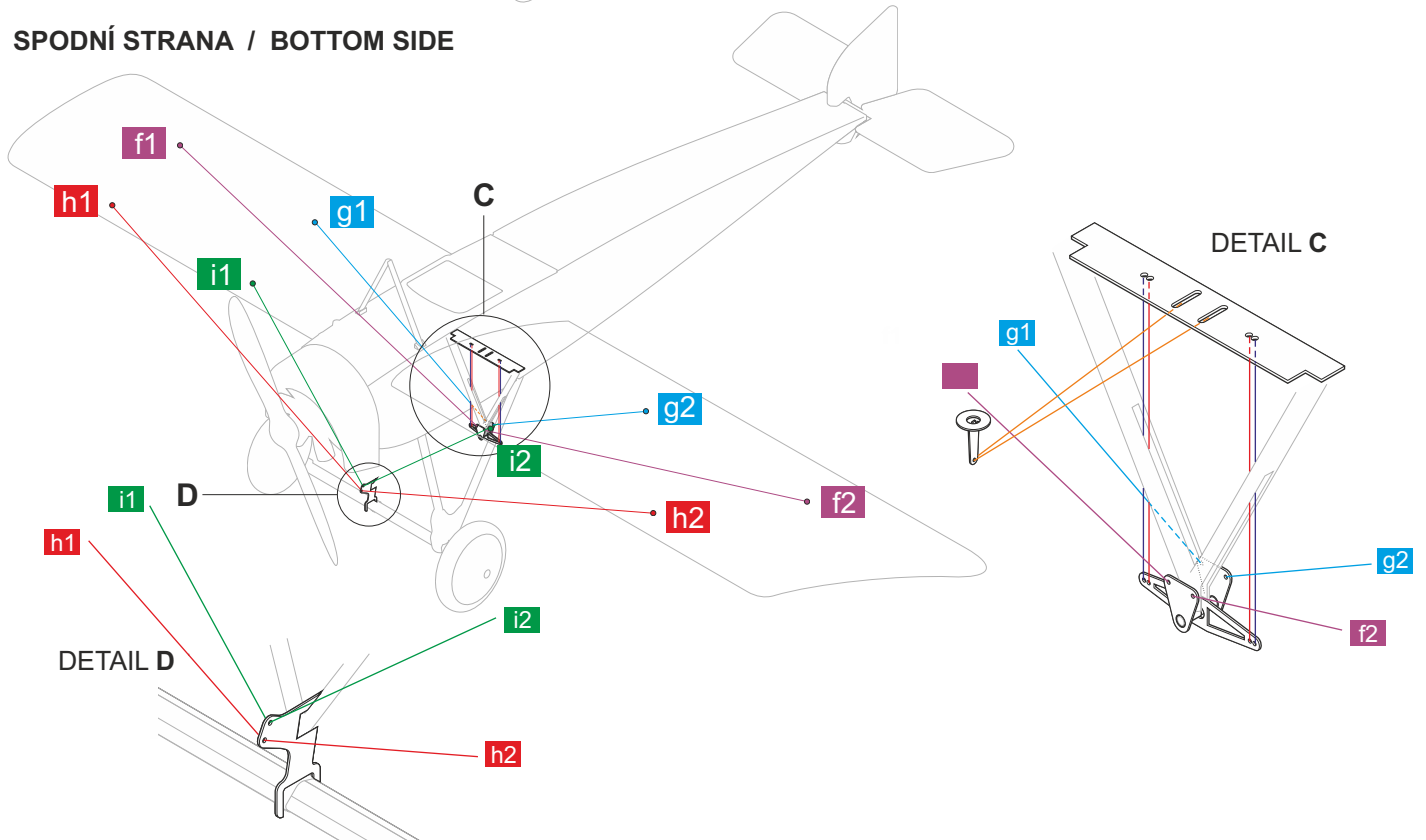

Pfalz E.I, tovární letiště firmy Pfalz, Speyer, 1916. Tento stroj byl na bocích ozdoben erbem, v literatuře často uváděno neznámým. Šlo ale o velký znak Bavorského království.

Pfalz E.I, factory airport of the company Pfalz, Speyer, 1916. This aircraft was decorated by a coat of arms, often described as unknown. It was however the greater coat of arms of the Bavarian kingdom.

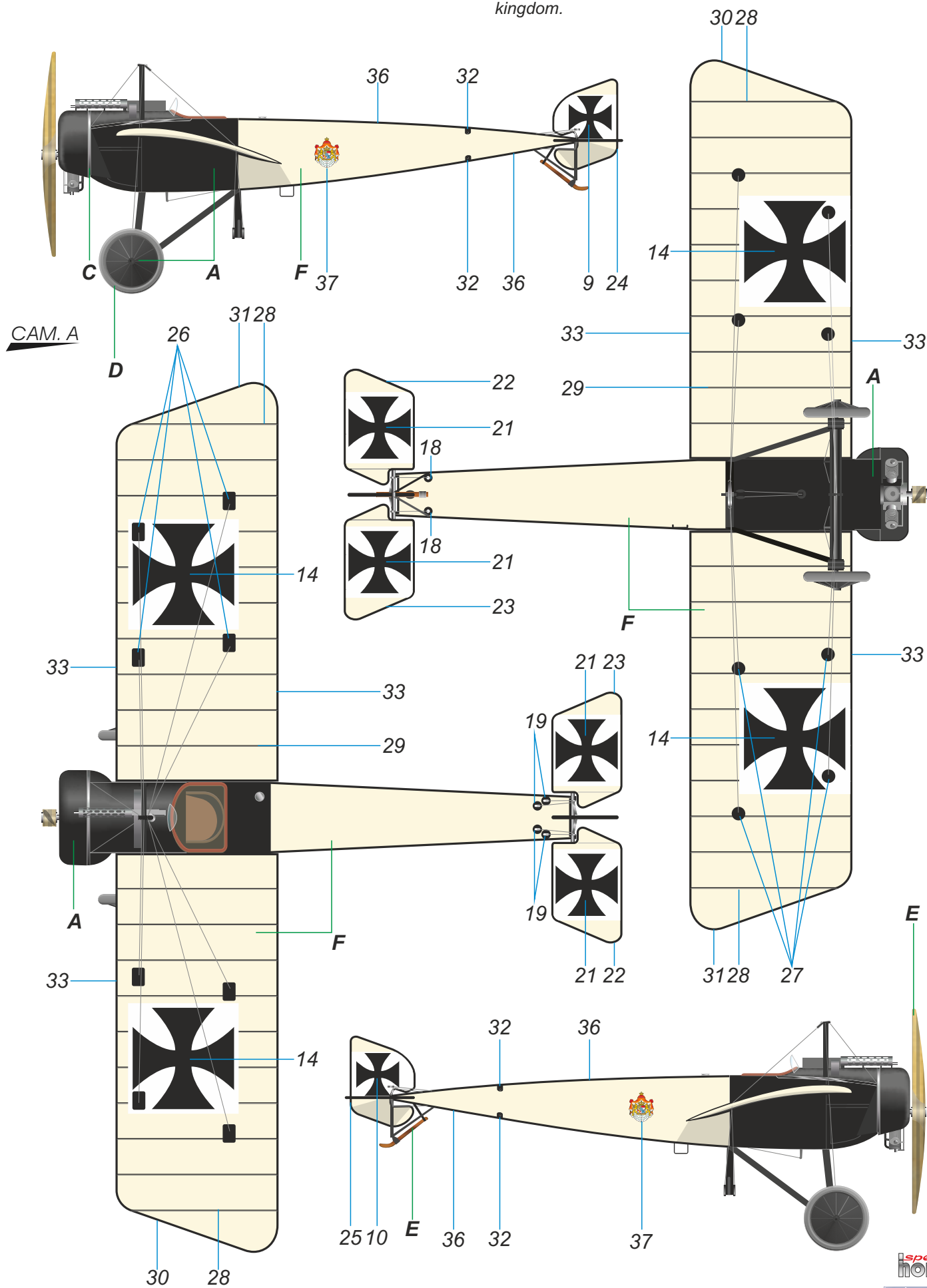

H2 / C2
Black
Černá



H8 / C8
Aluminium
Hliník



H324 / C324
Light Gray
Světle šedá



H37 / C43
Wood
Barva dřeva



H85 / C45
Linen
Barva plátna

Pfalz E.I 213/15. Tento Pfalz E.I je fotograficky doložen s výzbrojí a bez výzbroje. Plátěný potah trupu za kabinou a zejména levá polovina křídla byla značně znečištěna od oleje odstříkujícího z rotačního motoru.

Pfalz E.I 213/15. There are pictures showing this Pfalz E.I both equipped with a machine gun and without it. The canvas covered hull behind the canopy and especially the left part of the wing was considerably stained by oil dripping from the rotary engine.

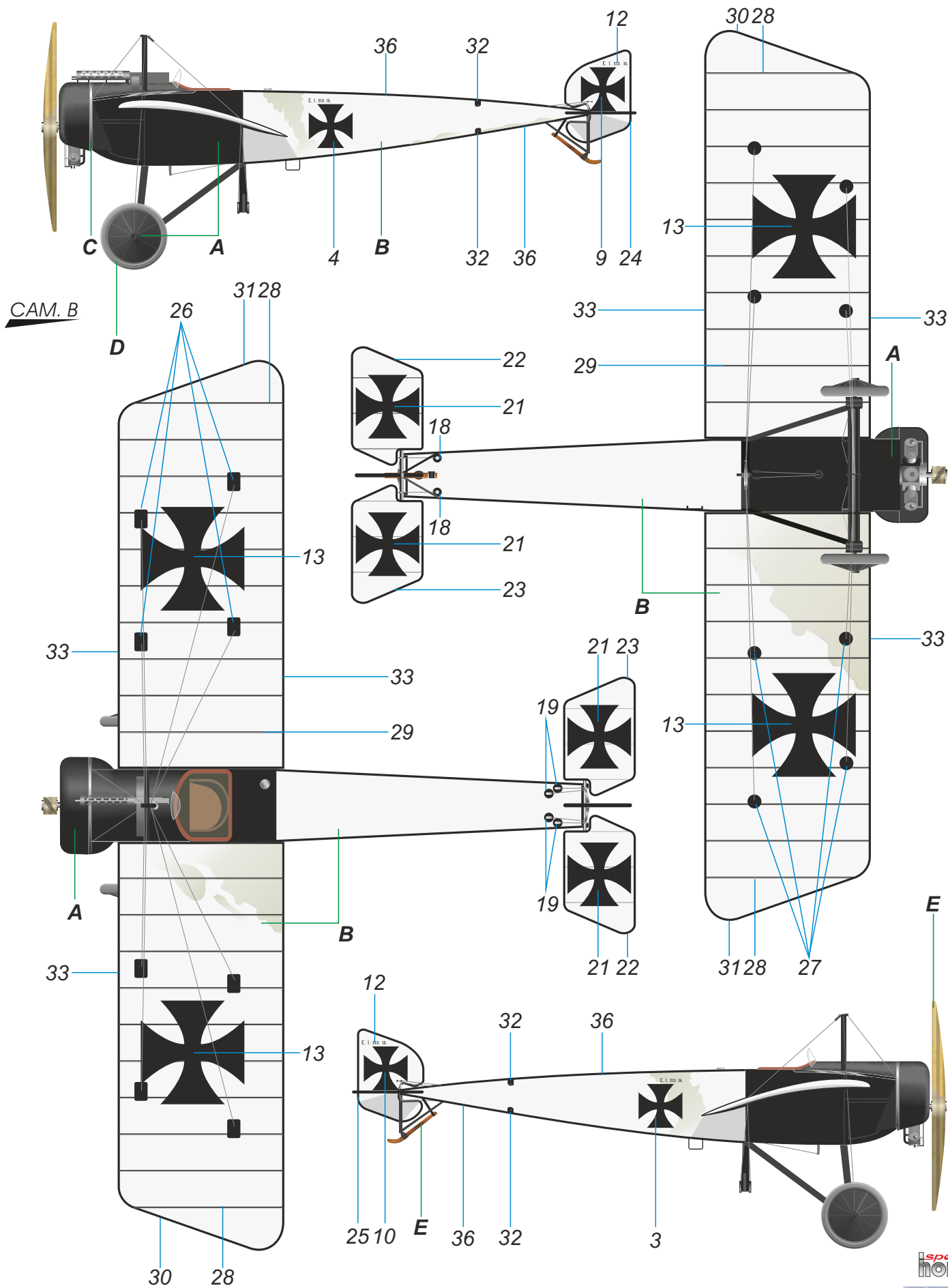

- | | | | | | | | | | |
|----------|---------------------------|----------|--|----------|--------------------------------|----------|--|----------|----------------------------------|
| A | H2 / C2 Black Černá | B | H21 / C69 Off White Špinavě bílá | C | H8 / C8 Aluminium Hliník | D | H324 / C324 Light Gray Světle šedá | E | H37 / C43 Wood Barva dřeva |
|----------|---------------------------|----------|--|----------|--------------------------------|----------|--|----------|----------------------------------|

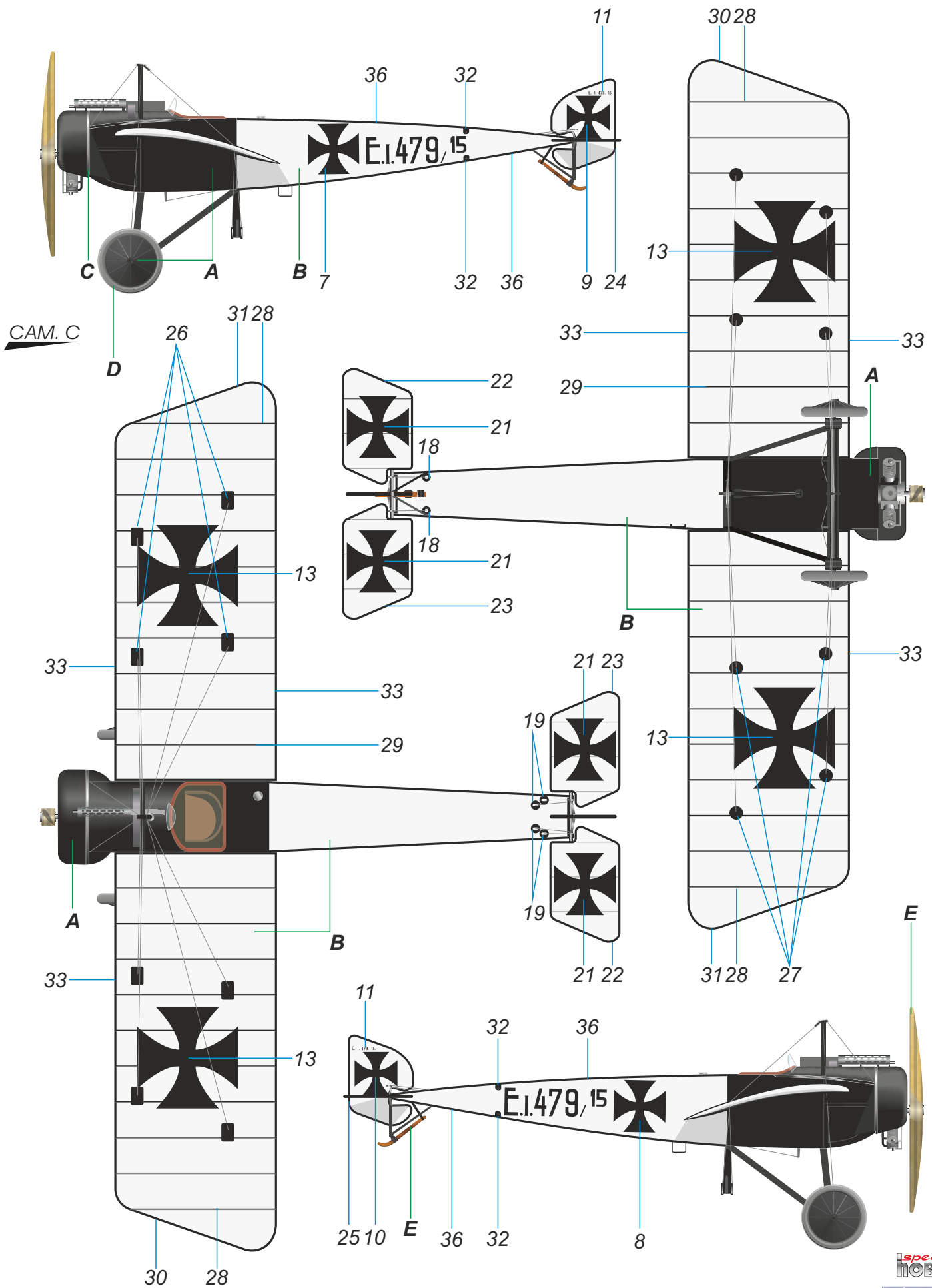

- A

H8 / C8
Aluminium
Hliník
- B

H8 / C8
Aluminium
Hliník
- C

H8 / C8
Aluminium
Hliník
- D

H8 / C8
Aluminium
Hliník
- E

H8 / C8
Aluminium
Hliník

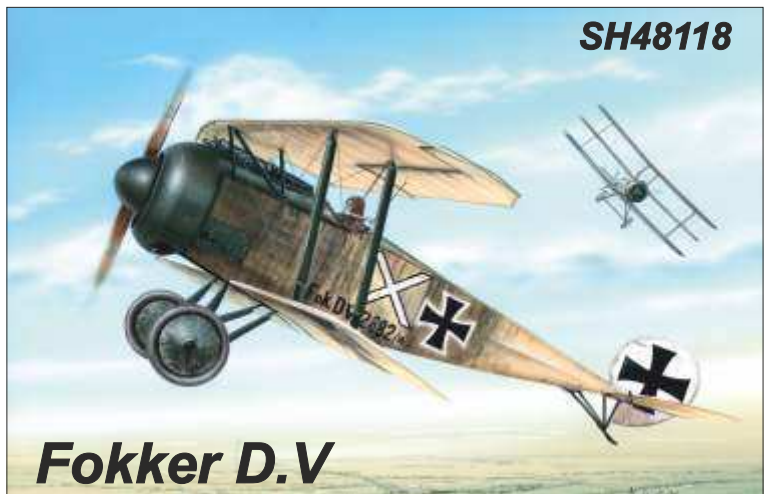

USE CMK TOOLS AND WEATHERING PIGMENTS FOR YOUR KITS.

H1010 HANDLE FOR OUR SAWS
- PRICELESS TOOL FOR RESIN PARTS ADJUSTMENT



H1011 CMK SANDING STICK
- FOUR DIFFERENT GRIT OF SANDING PAPERS ON ONE SANDING STICK.



Star Dust
weathering pigments