

# 648 517 P-51D gun bays

for Eduard kit - pro stavebnici Eduard

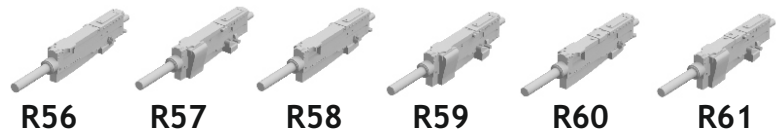

1/48 scale



R56 R57 R58 R59 R60 R61

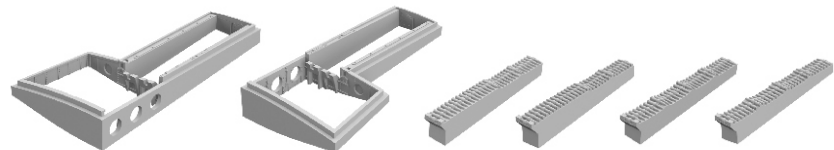

R62 R63 R64 R65 R66 R67

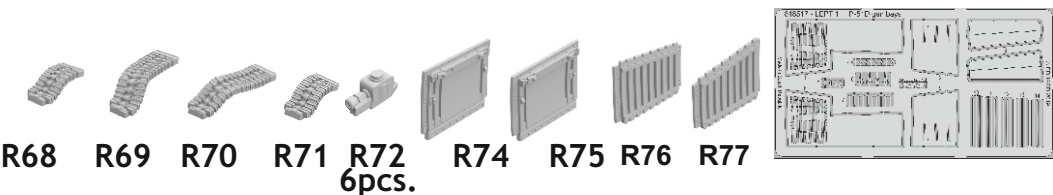

R68 R69 R70 R71 R72 R74 R75 R76 R77  
6pcs.

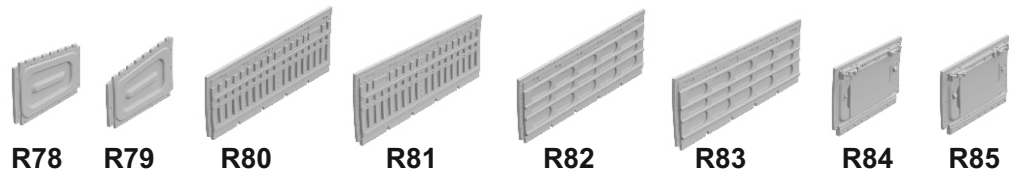

R78 R79 R80 R81 R82 R83 R84 R85

### COLOURS

GSI Creos (GUNZE)		Mr.METAL COLOR	
AQUEOUS	Mr.COLOR	Mr.METAL COLOR	
H 2	C 2	MC215	COPPER
H 8	C 8		
	C351		

This product contains metal and resin detail parts for upgrading scale plastic models. When selecting this set make sure that it is for the kit mentioned in product name as these sets are made specifically for that kit. When upgrading the model some cutting or corrections may be necessary for parts to fit accurately. **WARNING!** This set contains small and sharp parts. Work carefully in a ventilated and well-lit room. Safety glasses are recommended. This product is not suitable for children below 14 years of age.

Tento výrobek obsahuje leptané a odlávané detaily pro úpravu a vylepšení plastického modelu. Při výběru sady kovových detailů zkontrolujte, zda je určena pro model, který chcete upravit. Model, pro který je sada určena, je uveden u názvu výrobku. Pro přesnou aplikaci kovových a odlávaných dílů může být zapotřebí upravit díly upravovaného modelu. **POZOR!** Sada obsahuje malé ostré díly. Pracujte ve větrané a dobře osvětlené místnosti. Doporučujeme použití ochranných brýlí. Tento výrobek není vhodný pro děti mladší 14 let.

**eduard**  
435 21 Obrnice 170  
Czech Republic  
www.eduard.com

www.eduard.com  
19,95



# 648 517 P-51D gun bays

for Eduard kit - pro stavebnici Eduard

1/48

**BRASSIN**

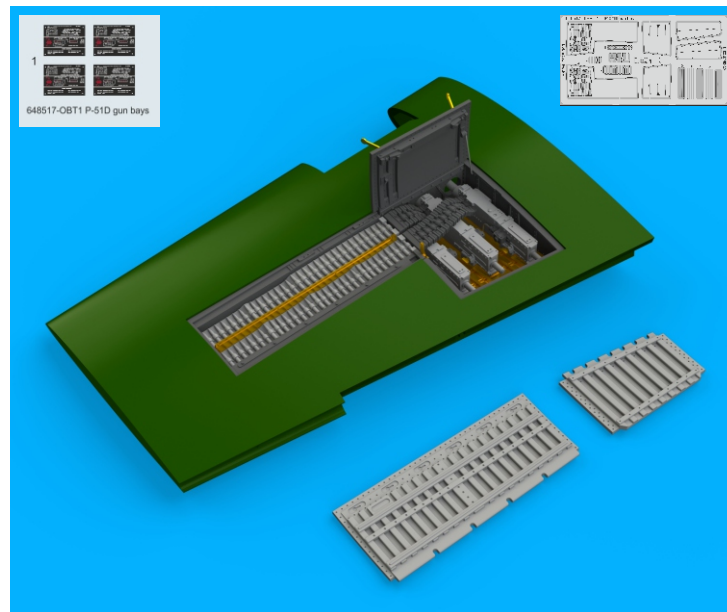

**BRASSIN**

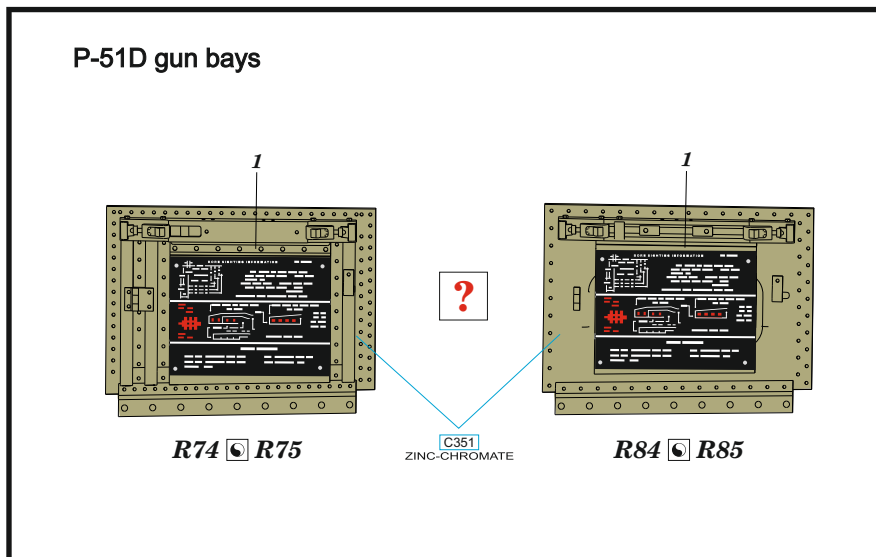

**BEST ~~BRASS~~ RESIN AROUND!**



3

A F

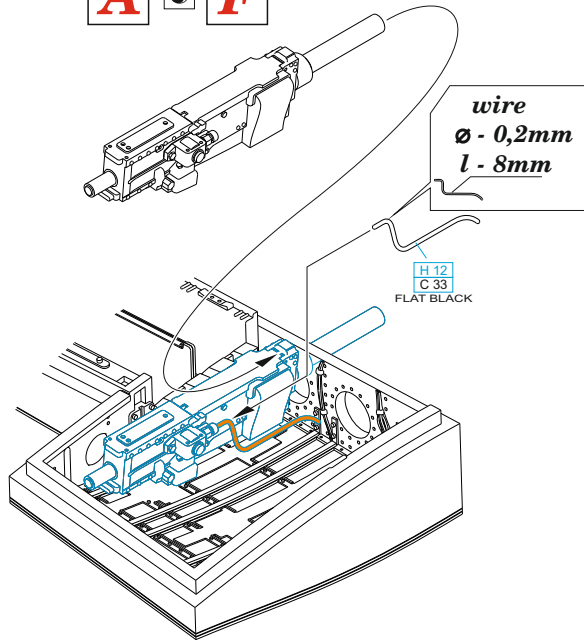

4

B E

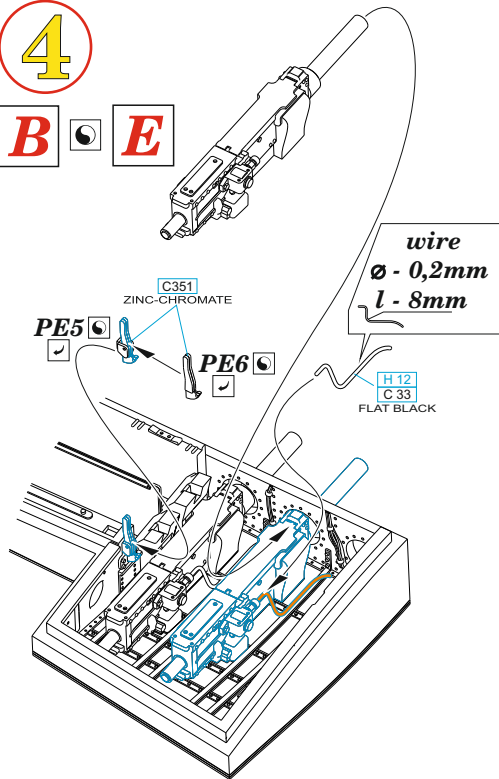

5

C D

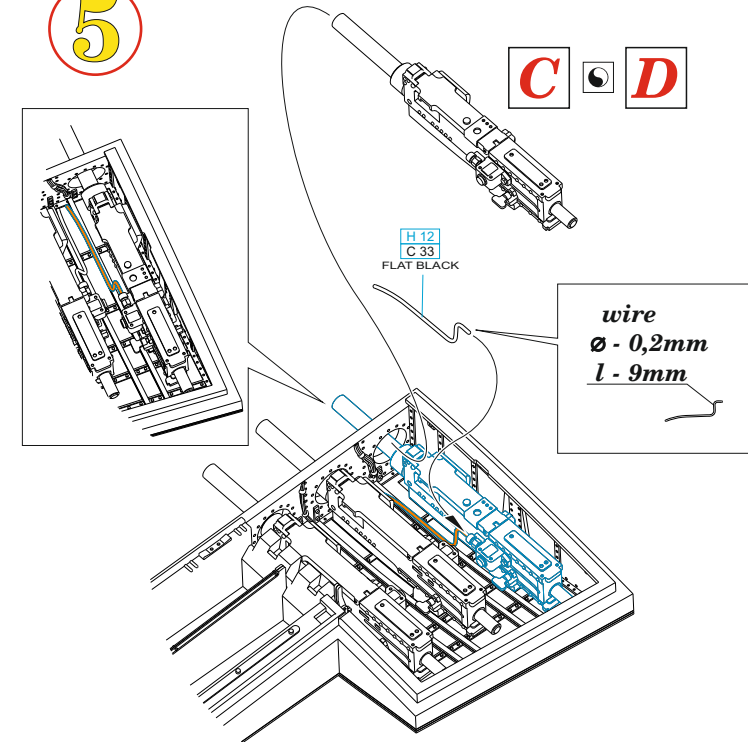

6

R66 R67 R64 R65

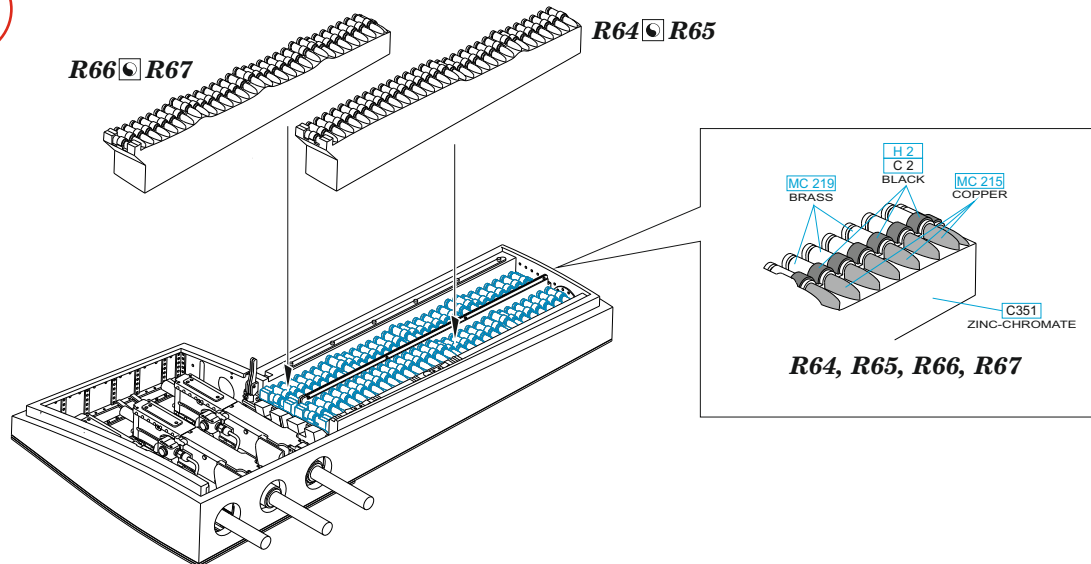

7

■ = □

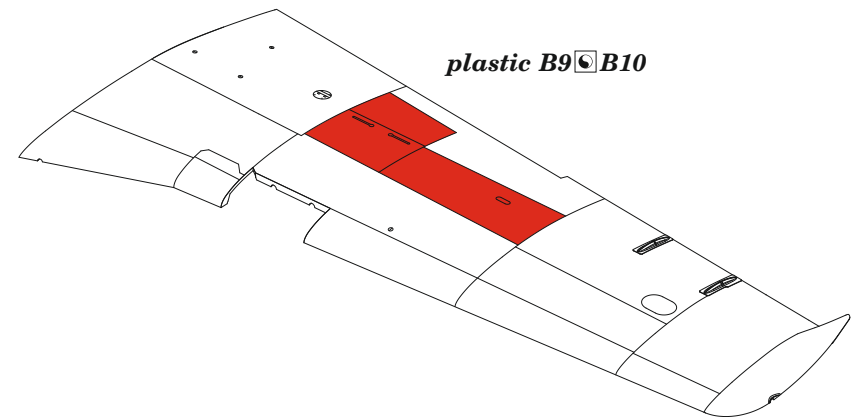

8

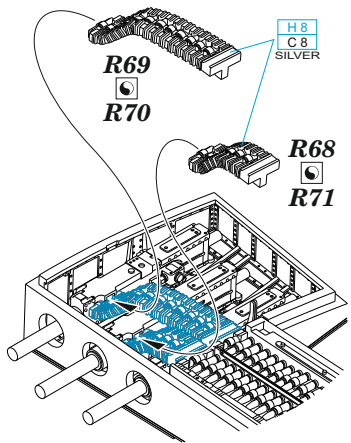

9

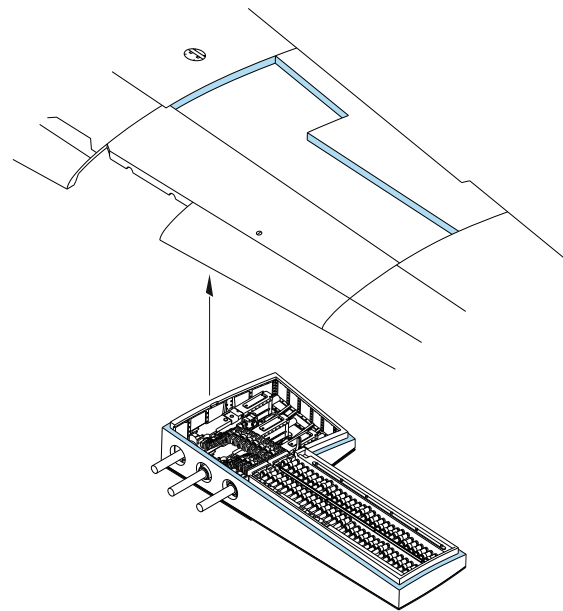

10

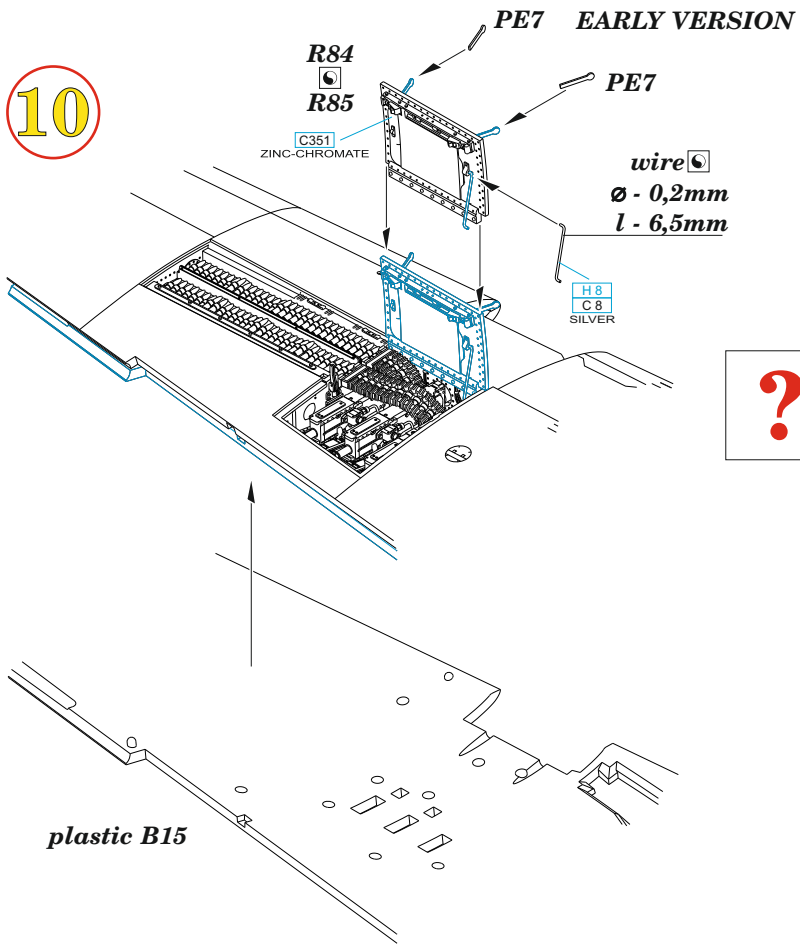

?

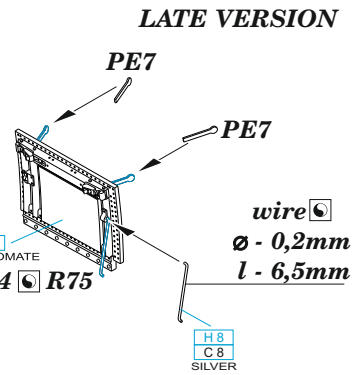

LATE VERSION

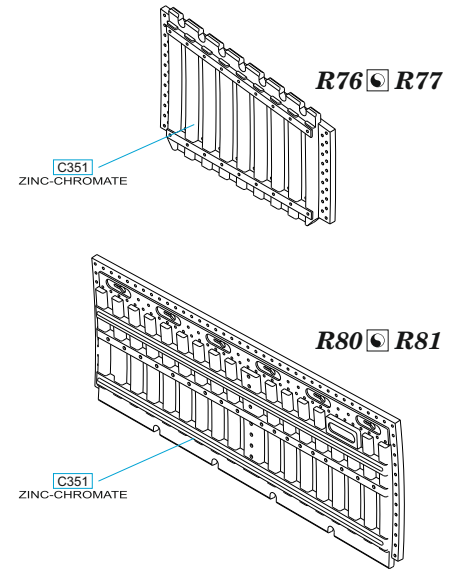

INNER SURFACES

EARLY VERSION

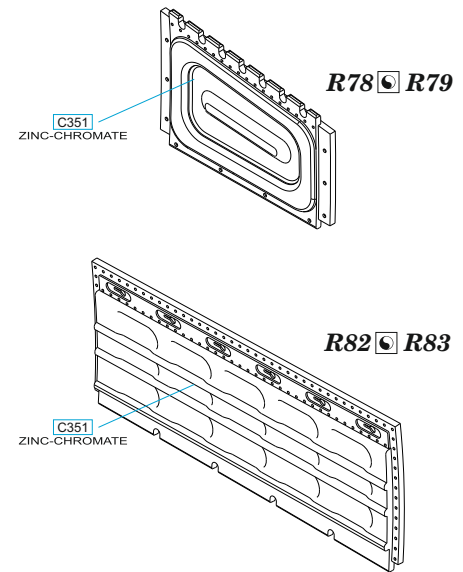

INNER SURFACES