

SOVIET SUPERSONIC FIGHTER 1:48 SCALE PLASTIC KIT



eduard

intro

ProfiPACK



The MiG-21 was one of a long list of Mikoyan-Gurevich products to be integrated into the armed forces of the Soviet Union, the Warsaw Pact, and allied client states. Its predecessors included such notable types as the MiG-15, MiG-17 and the supersonic MiG-19. The roots of this project reach back to the first half of the fifties. In 1954, the Ye-1 project came to an end, and was quickly picked up by the Ye-2. Both had a swept wing. The first machine to feature the delta wing was the Ye-4, which first took to the air on June 16th, 1955. It was also demonstrated a year later at the Moscow airfield Tushino. The first of the new line to enter production was the MiG-21F, which together with the MiG-21P and F-13 represented the first generation of the MiG-21, and was in production through the end of the fifties and the beginning of the sixties. Subsequent versions included the PF, FL, PFM, R, S, N and PD, the production of which peaked at the end of the sixties. The third generation started production in 1968, which included such versions as M, SM, MF, SMT, bis among others. Simultaneously, two-seat training versions were also produced designated MiG-21U, UM and US. Production of the MiG-21 ended in 1985, and was put into service with some fifty nations. Over the course of the cold war, the opponents of the MiG-21 included the likes of the Northrop F-5 Freedom Fighter and the Dassault Mirage III. NATO assigned it the reporting name 'Fishbed'. It became the most produced supersonic fighter in terms of quantity. The new machines came off Soviet production lines in Moscow, Gorky and Tbilisi. The MiG-21F-13 was also built under license in Czechoslovakia and the MiG-21FL, M and bis in India by Hindustan Aeronautics Ltd. The Soviet Union produced 10,645 examples of all versions, 194 were built in Czechoslovakia and 657 in India. Outside of the Soviet Union, the type flew with a long list of nations on all continents with the exception of Australia. The MiG-21 participated in combat in Vietnam, the Indo-Pakistan wars, the Cuban participation in Angola and in the Arab world's attempt to eliminate Israel. Thanks to the high volume of use, the highest number of aces produced on the type was in Vietnam. The top of the ladder is occupied by Nguyen Van Coc with nine kills. The type serving as a fighter-bomber served with the Soviet Union and other nations of the Warsaw Pact into the eighties, when it began to be displaced by the MiG-29 Fulcrum.

This kit is specific to the building of a model of the MiG-21PFM. In factory documentation, the export version is identified as 'Izdelye 94A' and the version built for Soviet armed forces as 'Izdelye 94'. It was powered by a Tumanskiy R-11F2-300, and armed with a twin barreled GSh-23 23mm cannon with 200 rounds housed in the underbelly pod GP-9. Hardpoints could still be loaded with RS-3US, R-3S and R-3R missiles, UB-16-57 rocket pods, S-24 unguided rockets and bombs up to 500kg in size. NATO assigned MiG-21PFM the codename 'Fishbed F'.

úvodem

MiG-21 byl další konstrukcí kanceláře Mikojan-Gurjevič, která se zařadila do výzbroje Sovětského svazu, zemí Varšavské smlouvy a dalších ozbrojených sil. Jeho předchůdci byly tak významné typy jako MiG-15, MiG-17 či nadzvukový MiG-19. Kořeny vývoje letounu sahají do první poloviny 50. let minulého století. V roce 1954 byl dokončen projekt Je-1, velmi rychle nahrazený druhým prototypem Je-2. Oba měly šípové křídlo. Prvním strojem s delta křídlem byl prototyp Je-4, který se do vzduchu dostal poprvé 16. června 1955. Představil se také na letecké přehlídce, která se konala o rok později na moskevském letišti Tušino. Jako první se do sériové výroby dostala verze MiG-21F, která společně s MiG-21P a MiG-21F-13 reprezentovala první generaci tohoto typu, vyráběnou na přelomu 50. a 60. let minulého století. Následovaly další, pokročilejší verze – PF, FL, PFM, R, S, N a PD, jejichž produkce vyvrcholila ve druhé polovině 60. let. Od roku 1968 probíhala výroba třetí generace, která zahrnovala například verze M, SM, MF, SMT, bis a další. Souběžně se stavěly také dvoumístné cvičné jednadvacítky MiG-21U, UM a US. Výroba MiGů-21 skončila v roce 1985 a do výzbroje je zařadilo okolo 50 zemí světa. MiG-21 měl během studené války své protějšky v typech Northrop F-5 Freedom Fighter či Dassault Mirage III. Vojska NATO dalo typu kódové označení Fishbed. Stal se v největších počtech vyráběným nadzvukovým letounem. Nové stroje v Sovětském svazu sjížděly z továrních linek v Moskvě, Gorkém a Tbilisi. V licenci se stavěla verze MiG-21F-13 v Československu a MiG-21FL, M a bis v Indii u Hindustan Aeronautics Ltd. V Sovětském svazu vzniklo 10 645 exemplářů všech verzí, v Československu 194 kusů a v Indii 657 strojů. Kromě ozbrojených sil Sovětského svazu létal s řadě zemí, s výjimkou Austrálie na všech kontinentech. Zúčastnil se řady válečných konfliktů, včetně války ve Vietnamu, indicko-pákistánských potyček, kubánského tažení v Angole či arabské snahy o zničení Izraele. Díky největšímu zapojení do bojových akcí se největší počet stíhacích es zrodil ve Vietnamu. Na čele žebříčku stojí Nguyen Van Coc s devíti sestřely. V roli přepadového stíhacího letounu sloužily MiGy-21 v Sovětském svazu a dalších zemích Varšavské smlouvy až do 80. let, kdy jej jako plnohodnotná náhrada začaly z prvoliniové služby vytlačovat nové MiGy-29 Fulcrum.

Z této stavebnice si můžete postavit MiG-21PFM. V tovární dokumentaci tato verze figuruje pod označením Izdělje 94A pro exportní stroje a Izdělje 94 pro letouny určené pro sovětské ozbrojené síly. Poháněl jej motor Tumanskiy R-11F2-300. Výzbroj tvořil dvouhlavňový kanon GŠ-23 ráže 23 mm se zásobou 200 ran v kontejneru GP-9 pod trupem. Podvěsnou výzbroj tvořily rakety RS-3US, R-3S, R-3R, popř. raketové bloky UB-16-57, protizemní neřízené rakety S-24 a pumy do 500 kg. V kódu NATO nesly stroje označení Fishbed F.

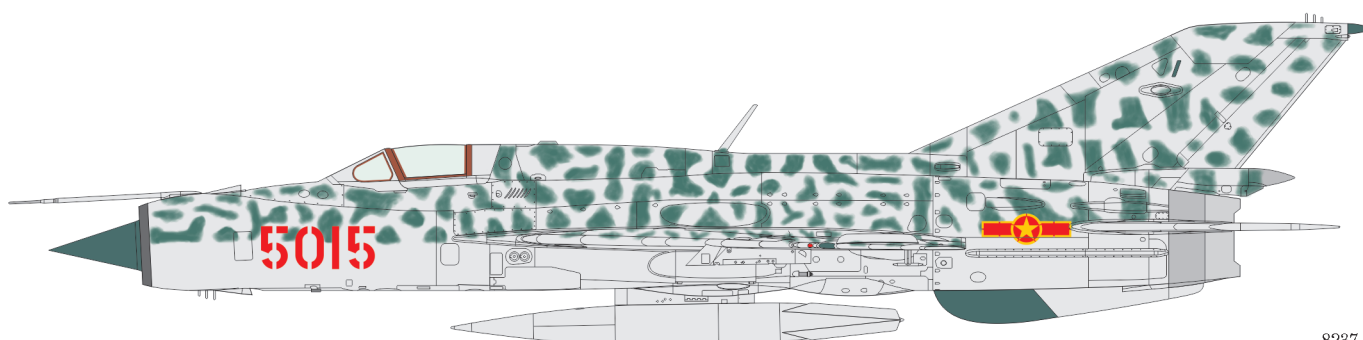



Carefully read instruction sheet before assembling. When you use glue or paint, do not use near open flame and use in well ventilated room. Keep out of reach of small children. Children must not be allowed to suck any part, or pull vinyl bag over the head.



Před započítím stavby si pečlivě prostudujte stavební návod. Při používání barev a lepidel pracujte v dobře větrané místnosti. Lepidla ani barvy nepoužívejte v blízkosti otevřeného ohně. Model není určen malým dětem, mohlo by dojít k požití drobných dílů.

INSTRUCTION SIGNS * INSTR. SYMBOLS * INSTRUKTION SINNBILDEN * SYMBOLES * 記号の説明



OPTIONAL
VOLBA



BEND
OHNOUT



OPEN HOLE
VYVRTAT OTVOR



SYMMETRICAL ASSEMBLY
SYMETRICKÁ MONTÁŽ



REMOVE
ODŘÍZNOUT



REVERSE SIDE
OTOČIT



APPLY EDUARD MASK
AND PAINT
POUŽÍT EDUARD MASK
NABARVIT

PARTS



DÍLY



TEILE



PIÈCES



部品

PLASTIC PARTS

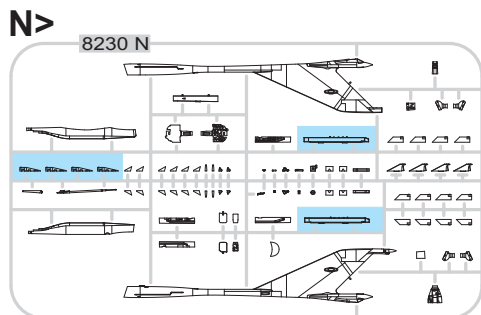
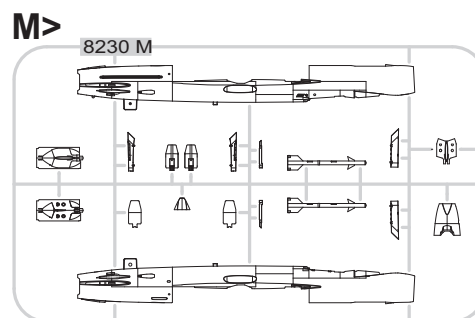
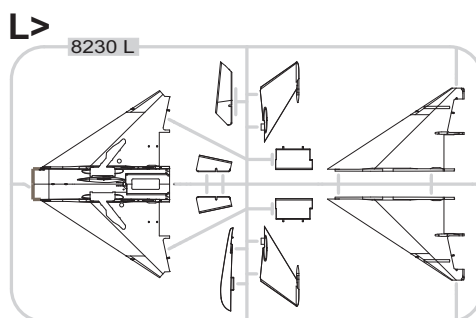
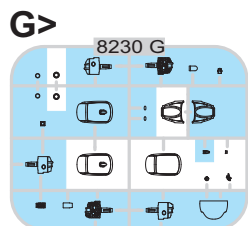
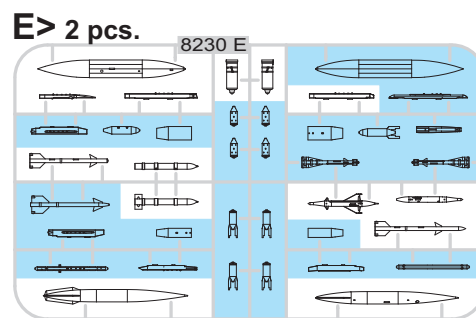
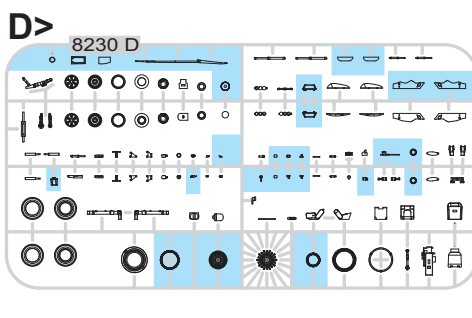
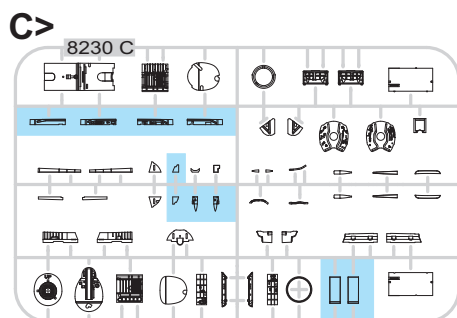

eduard
MASK



PE - PHOTO ETCHED DETAIL PARTS

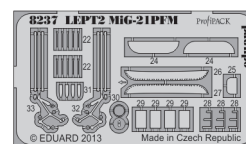
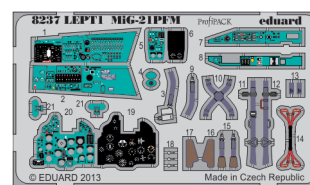

-Parts not for use. -Teile werden nicht verwendet. -Pièces à ne pas utiliser.
-Tyto díly nepoužívejte při stavbě. - 使用しない部品

COLOURS



BARVY



FARBEN



PEINTURE



色

GSI Creos (GUNZE)		
AQUEOUS	Mr.COLOR	
H 1	C1	WHITE
H 3	C3	RED
H 4	C4	YELLOW
H 5	C5	BLUE
H 6	C6	GREEN
H 12	C33	FLAT BLACK
H 13	C3	FLAT RED
H 26	C66	BRIGHT GREEN
H 27	C44	SAND
H 44	C51	SAND
H 47	C41	RED BROWN
H 51	C11	LIGHT GRAY

AQUEOUS	Mr.COLOR	
H 53	C13	NEUTRAL GRAY
H 58	C27	INTERIOR GREEN
H 66	C19	LIGHT SAND
H 67	C115	LIGHT BLUE
H 70	C60	GRAY
H 77	C137	TIRE BLACK
H 81	C55	KHAKI
H 90	C47	CLEAR RED
H 94		CLEAR GREEN
H 304	C304	GREEN
H 317	C317	GRAY
H 318	C318	RADOME
H 324	C324	LIGHT GRAY
H 328	C328	BLUE

AQUEOUS	Mr.COLOR	
H 332	C332	LIGHT GRAY
H 340	C340	GREEN
H 417	C76	LIGHT BLUE
	C8	SILVER
	C34	SKY BLUE
	C80	COBALT BLUE
	C370	AZURE BLUE
Mr.METAL COLOR		
	MC213	STAINLESS STEEL
	MC214	DARK IRON
	MC218	ALUMINIUM
Mr.COLOR SUPER METALLIC		
	SM06	CHROME SILVER

INTERIOR COLOUR BARVA INTERIÉRU

INTERIOR

60% C34 SKY BLUE + 20% C66 BRIGHT GREEN + 20% C80 COBALT BLUE

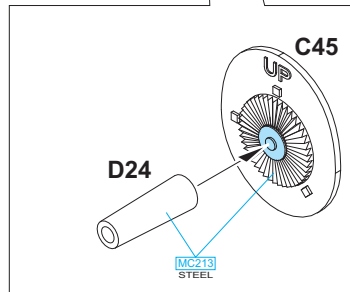
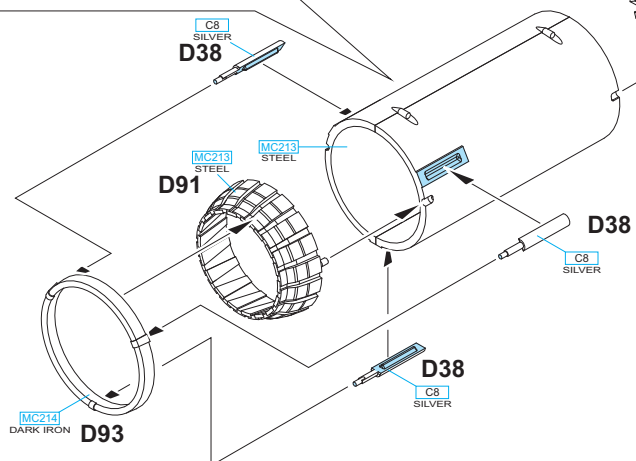
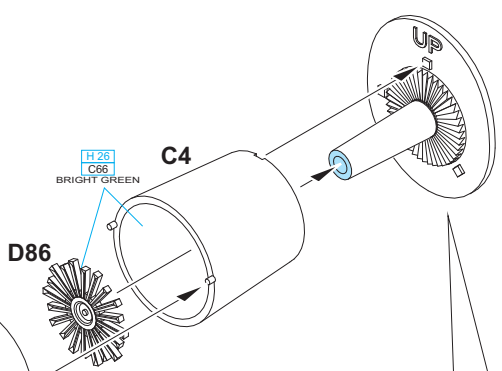
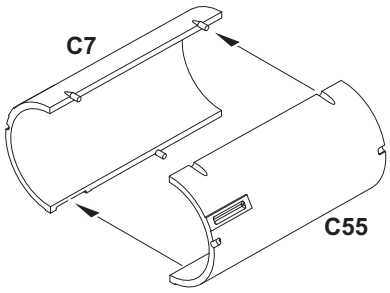
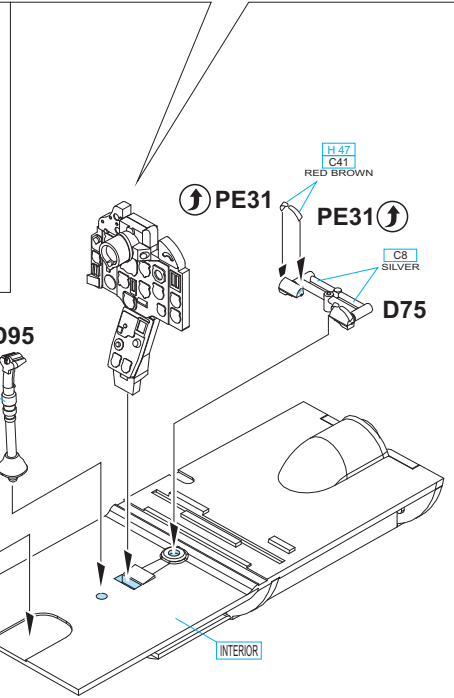
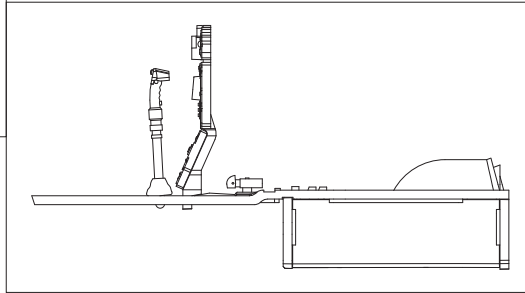
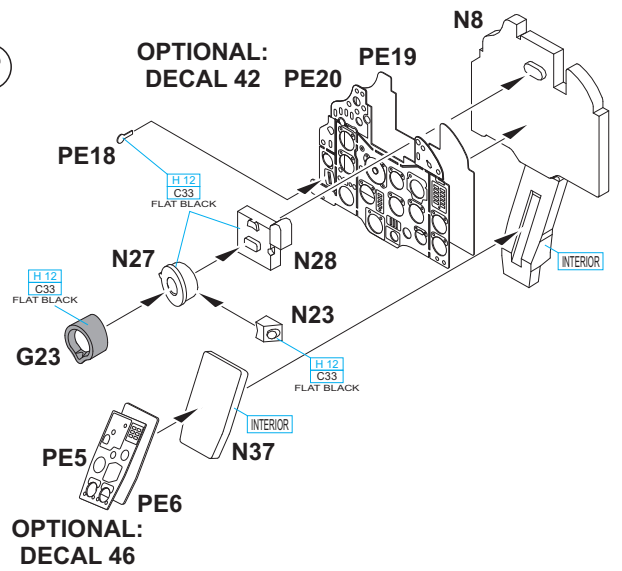
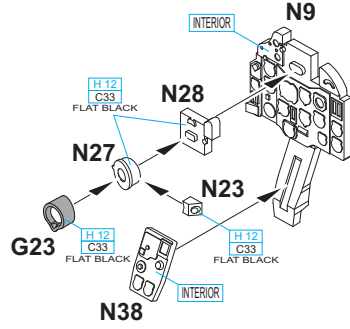
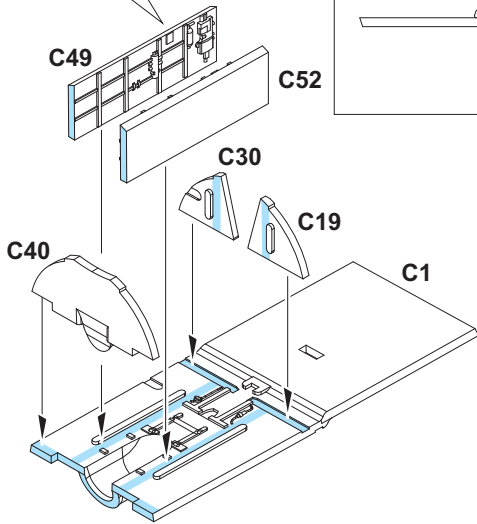
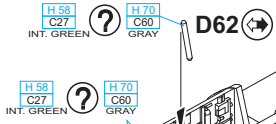
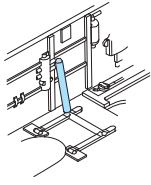

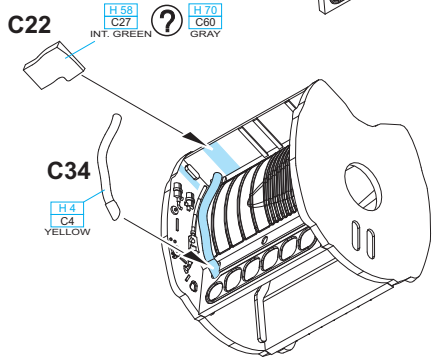
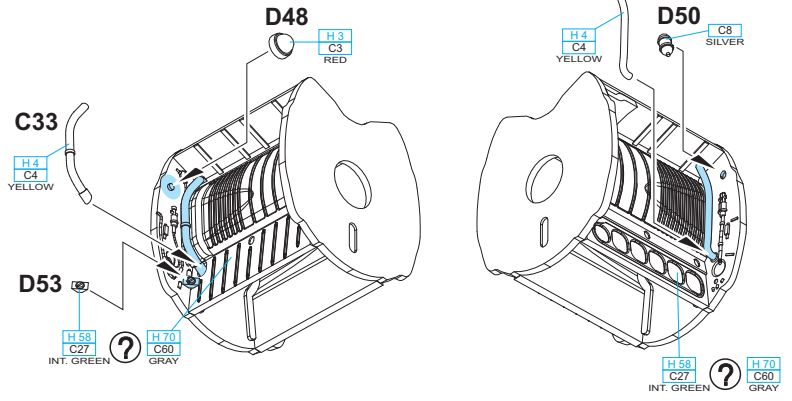
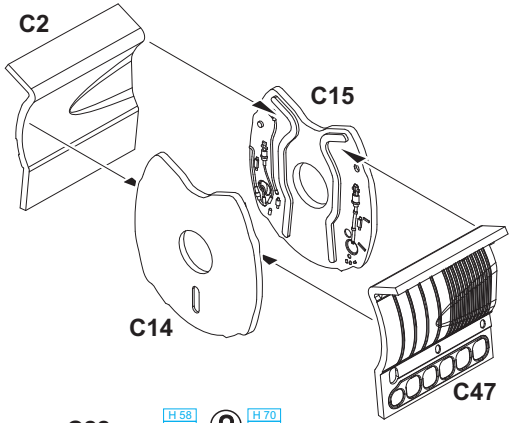

OPTIONAL:
DECAL 44

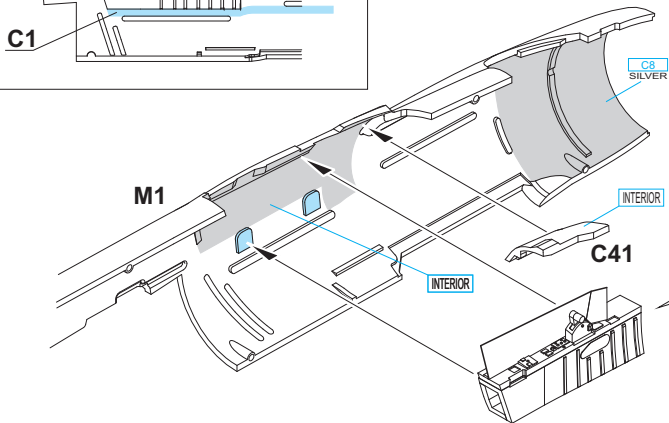
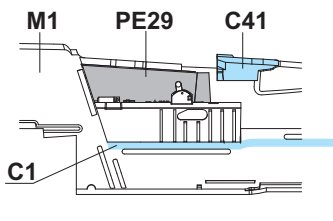
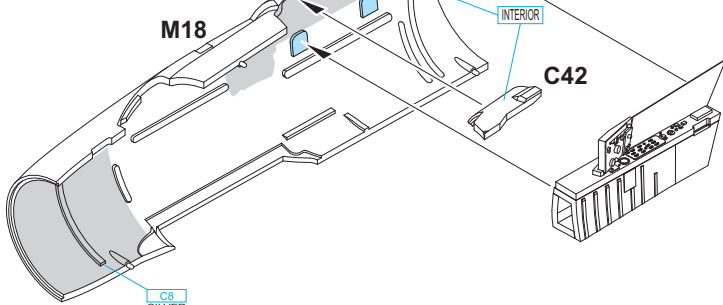
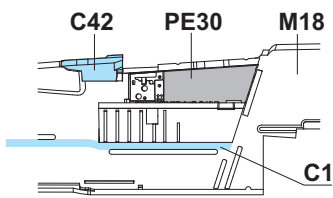
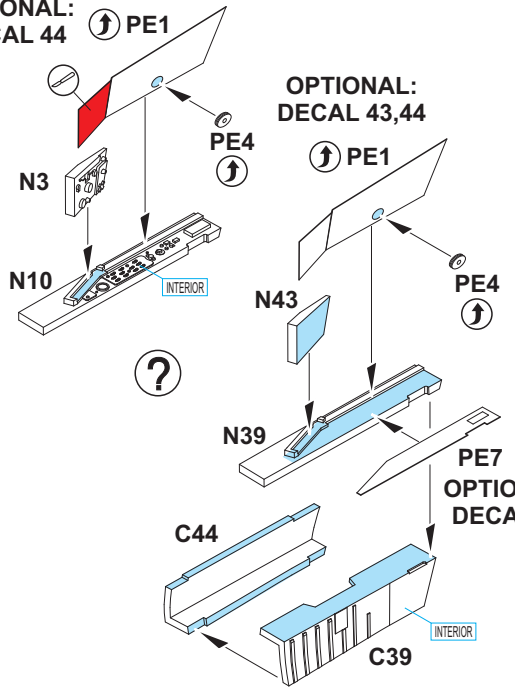

OPTIONAL:
DECAL 41

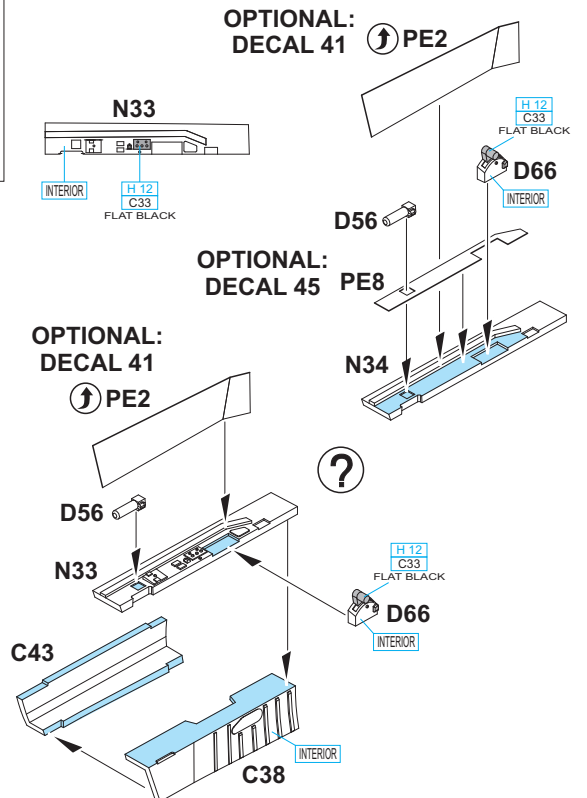

**FOR OPEN AIR BRAKES ONLY
JEN PRO OTEVŘENÉ ŠTÍTY**

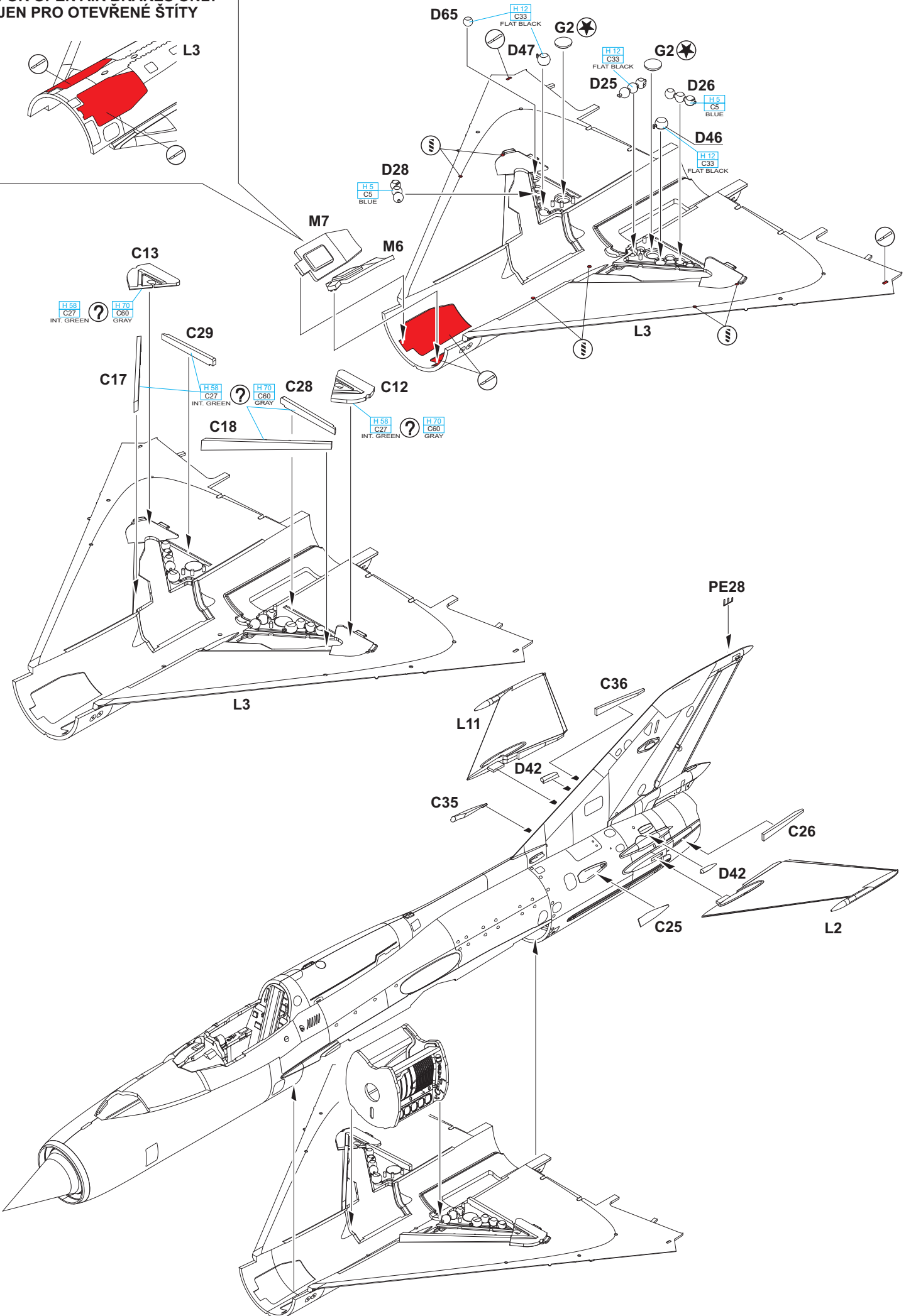
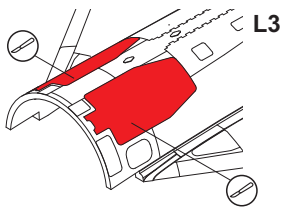

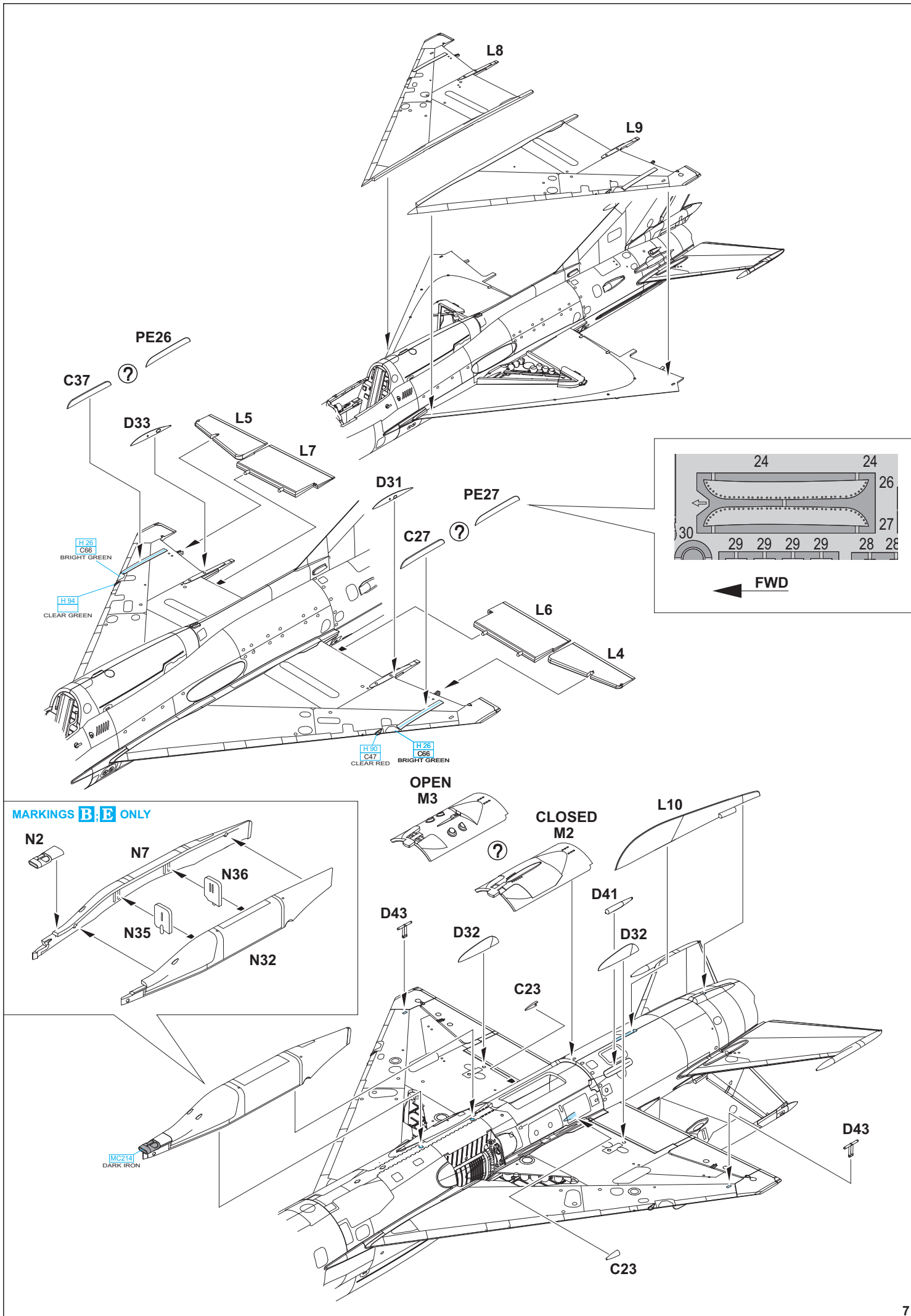

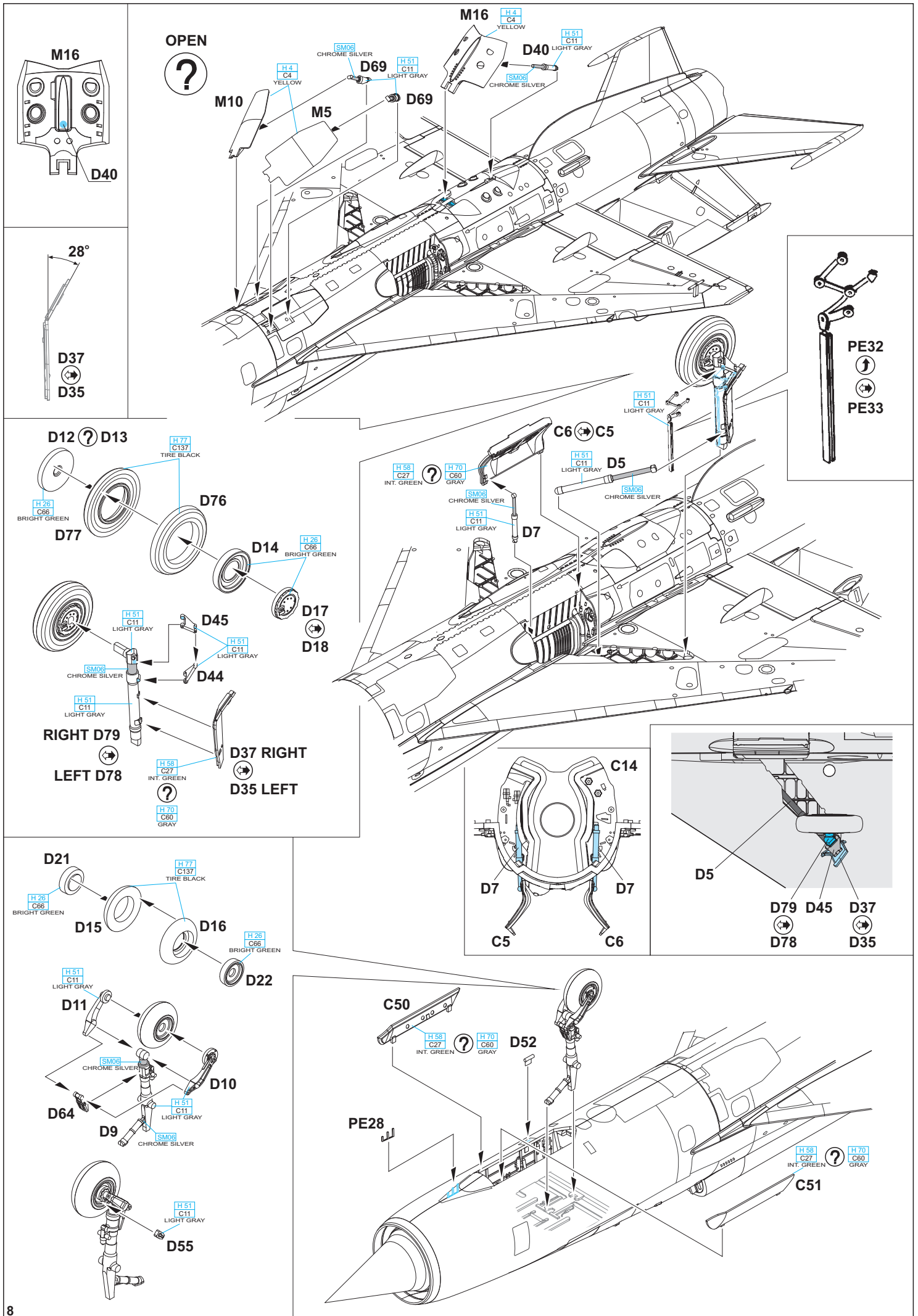

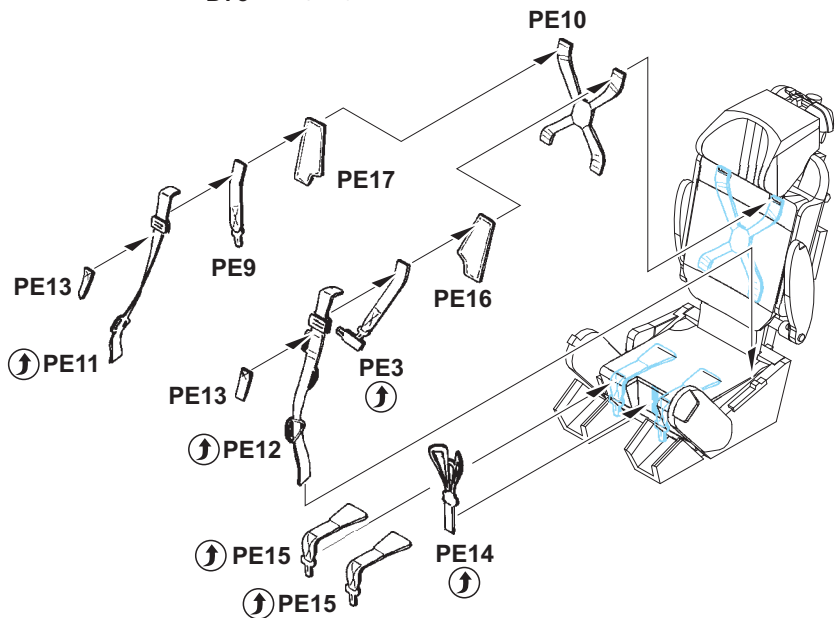
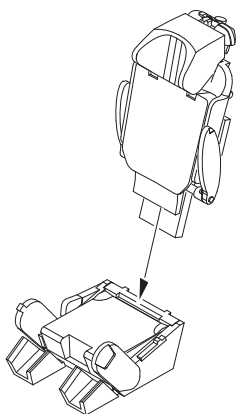
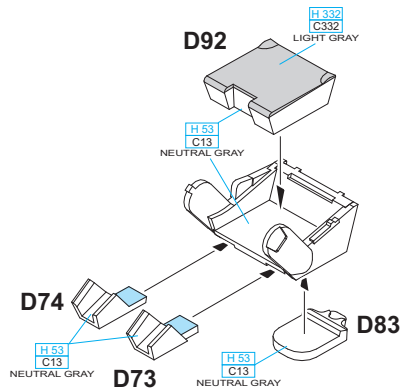
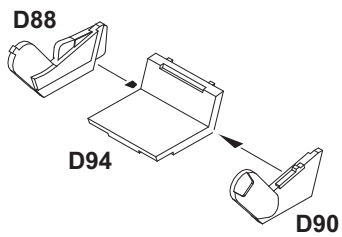
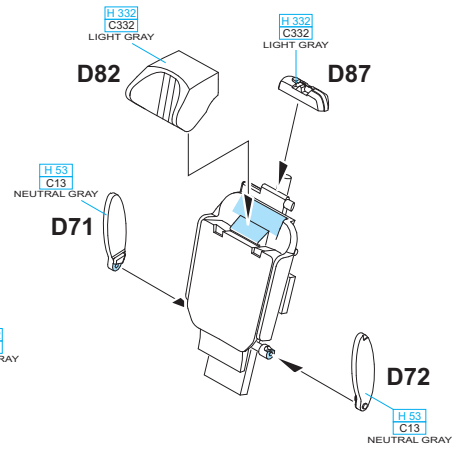
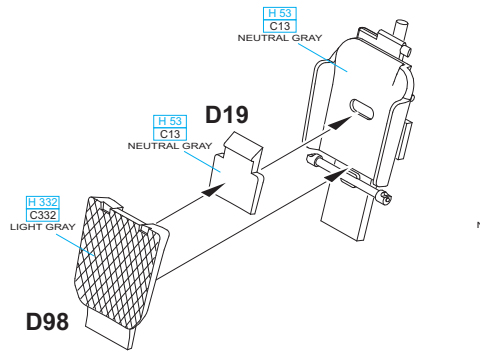
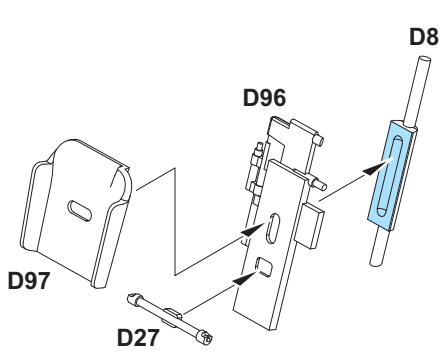
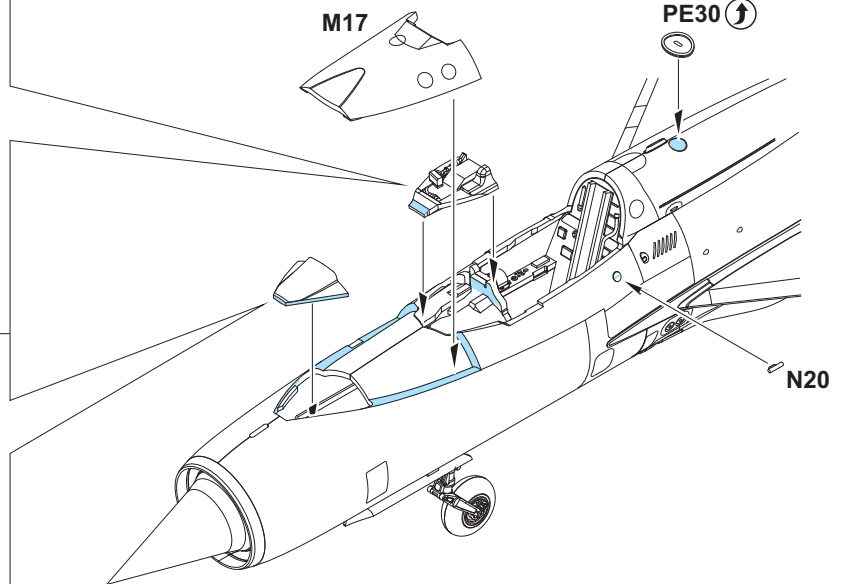
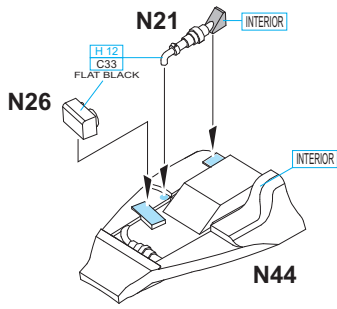

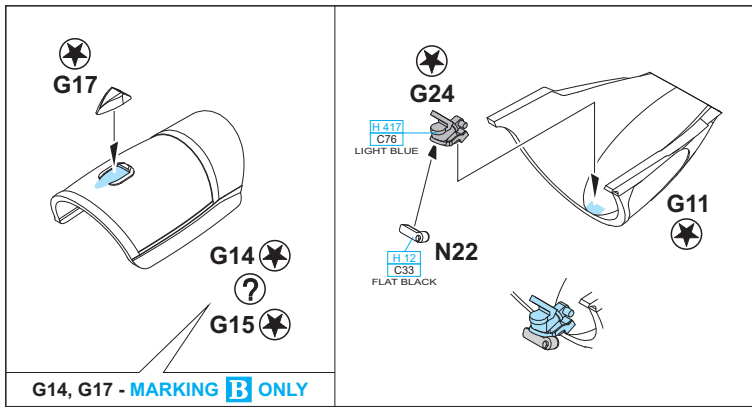

G14, G17 - MARKING B ONLY

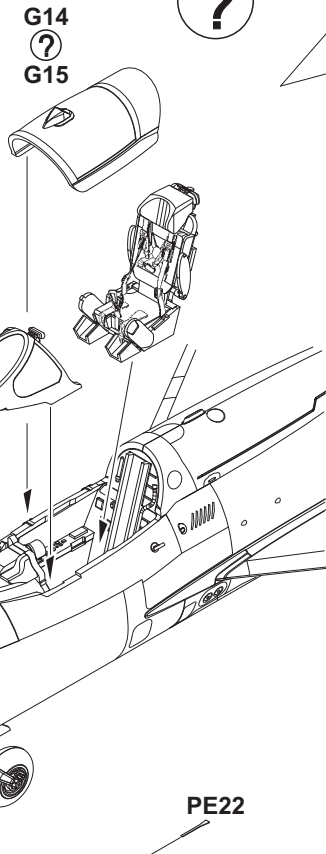
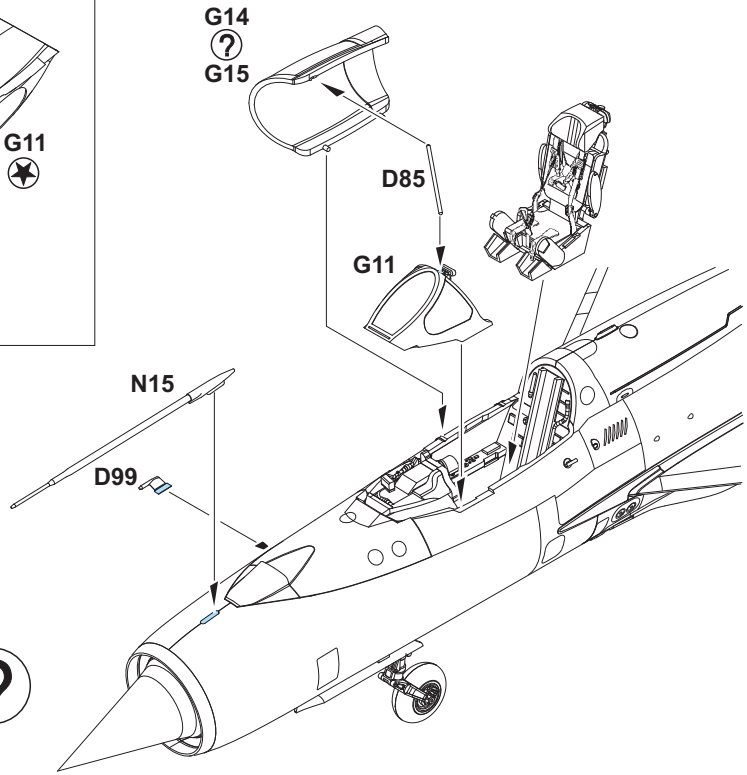
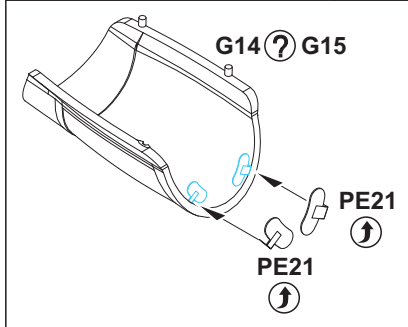

<p>G14, G17</p> <p>MARKING C</p>	<p>G15</p> <p>MARKINGS A; D</p>	<p>G15</p> <p>MARKINGS B; E</p>
----------------------------------	---------------------------------	---------------------------------

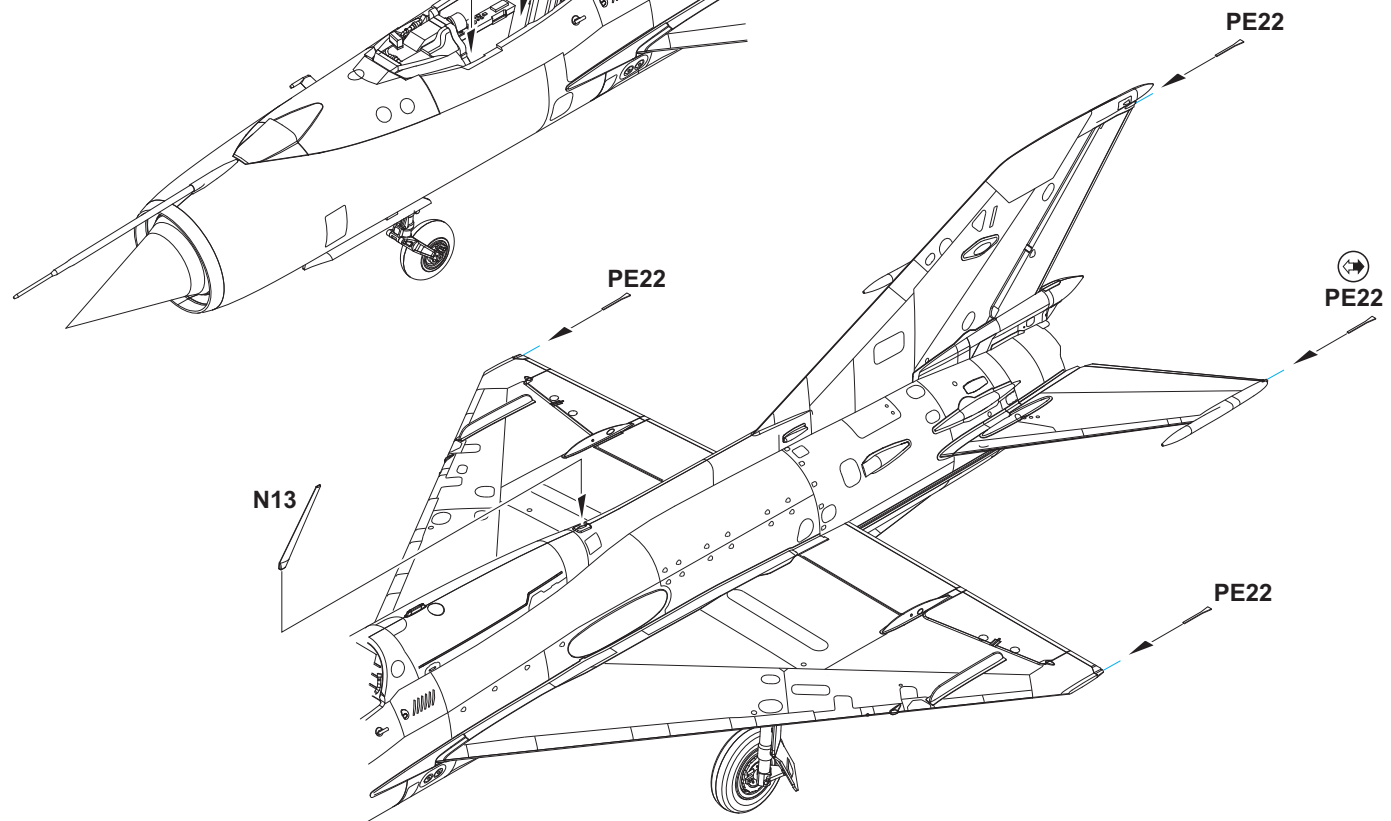

EXTERNAL FUEL TANK 490I
PRÍDAVNÁ NÁDRŽ 490I
 2 pcs.

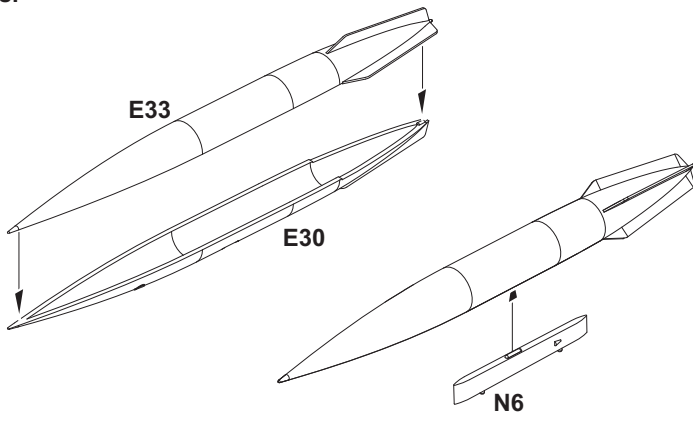

S-24
 2 pcs.

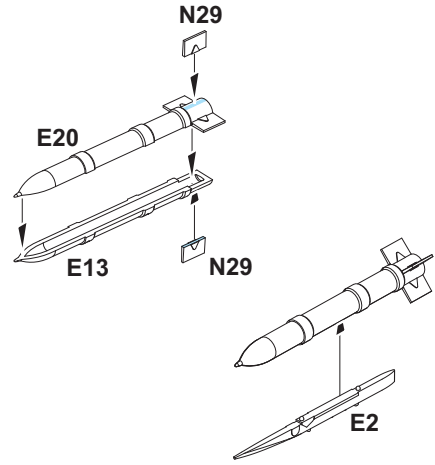

R-3S
 4 pcs.

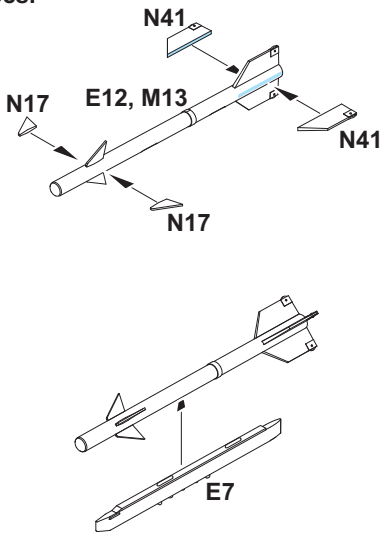

RS-2US
 2 pcs.

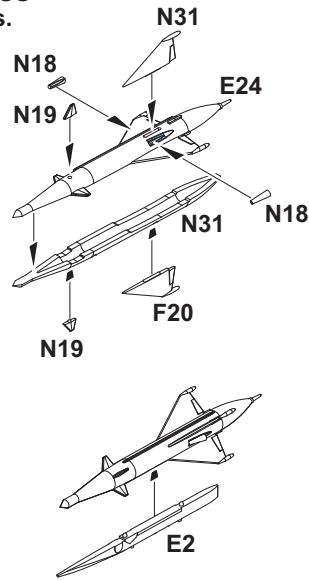

R-3R
 2 pcs.

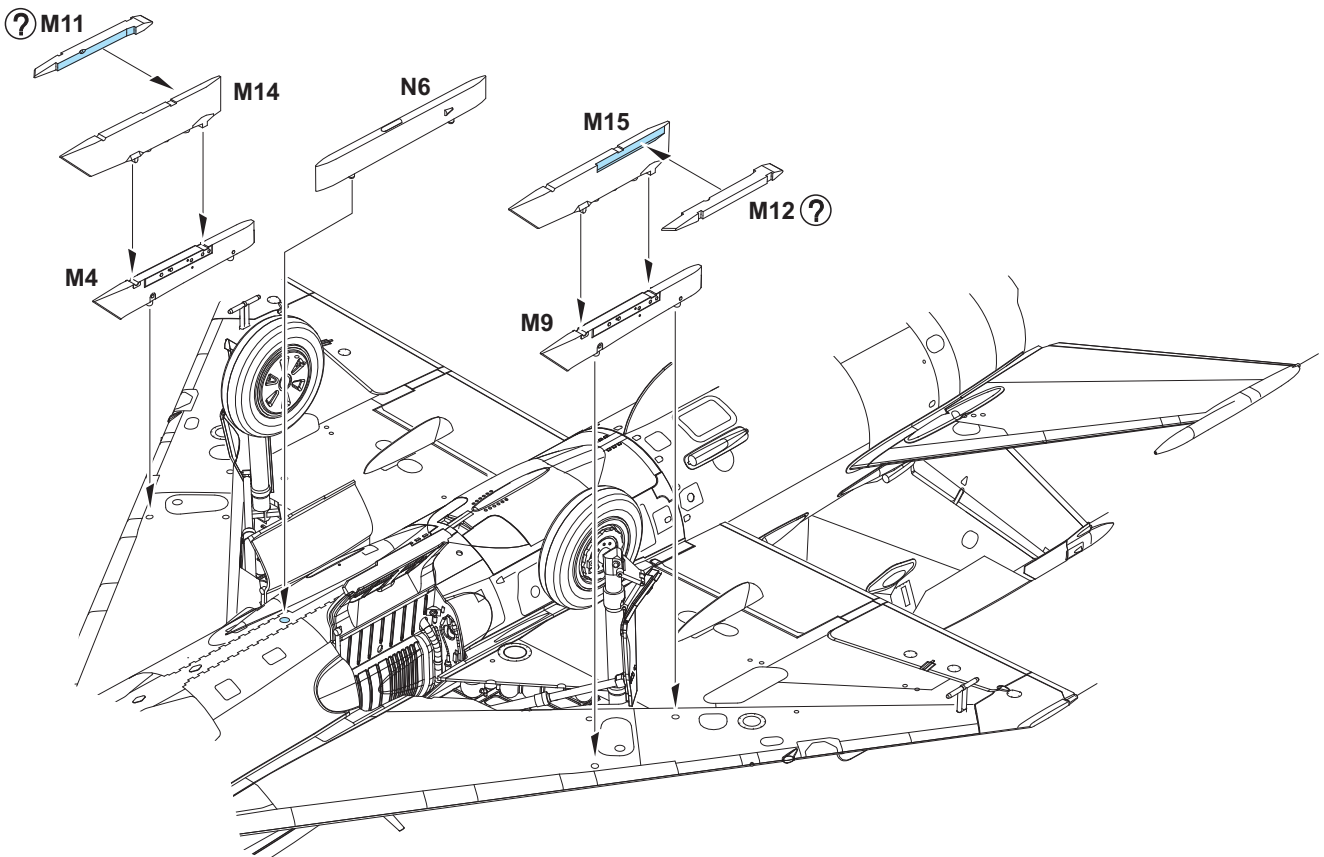
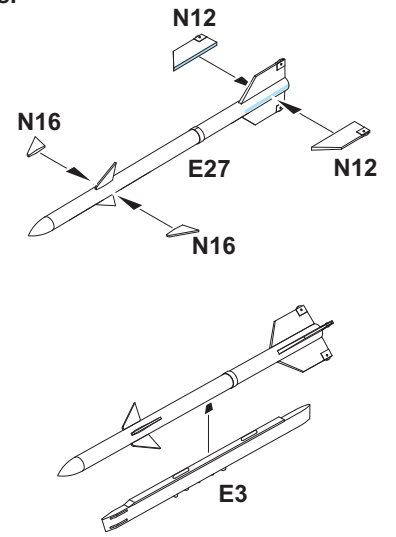

TO CHOOSE WEAPON AND EXTERNAL FUEL TANK OPTION PLEASE FOLLOW YOUR REFERENCE.

PRO VOLBU VÝZBROJE A PŘÍDAVNÝCH NÁDRŽÍ SE DRŽTE DOKUMENTACE KONKRÉTNÍHO STROJE.

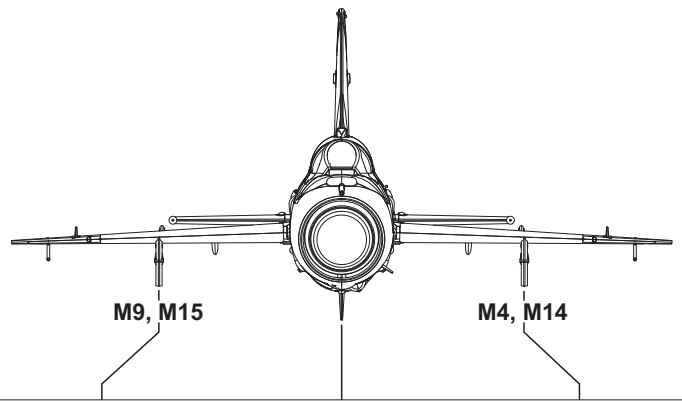

EXTERNAL FUEL TANK 490I

	N6	
S-24	E2	E2
RS-2US	E2	E2
R-3S	E7	E7
PBP-2-3S Monsun	M9, M12, M15	M4, M11, M14

MARKING **B** ONLY
PBP-2-3S Monsun

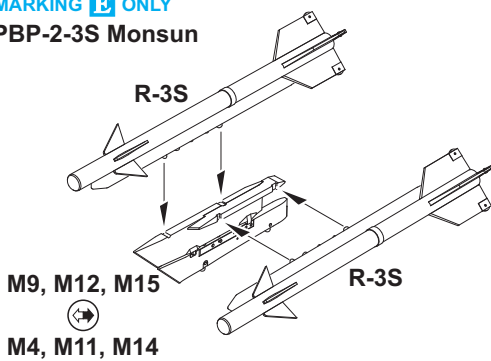

SPRD

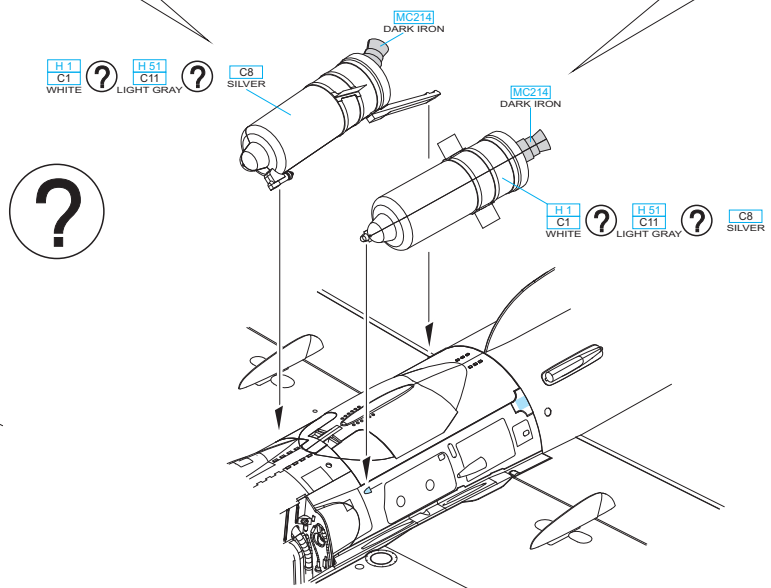
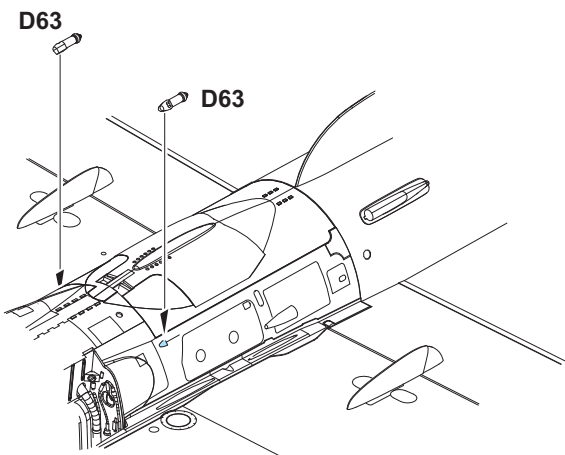
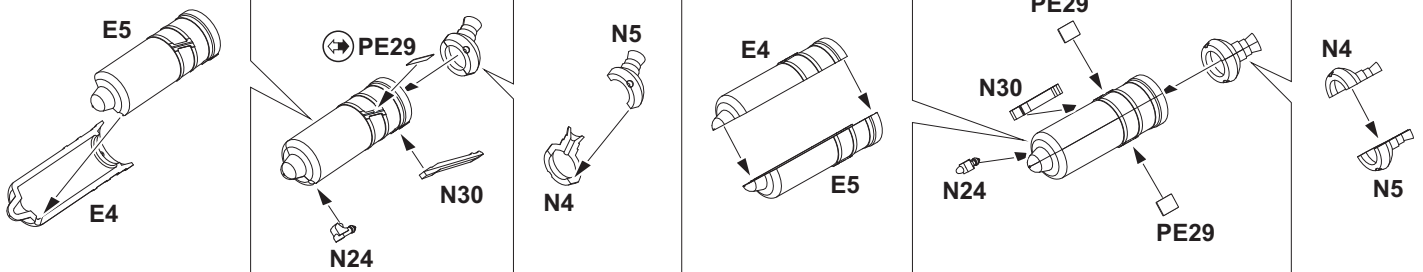

eduard
MASK
8237

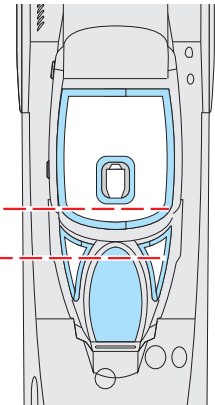
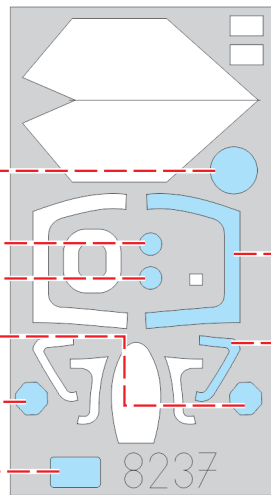
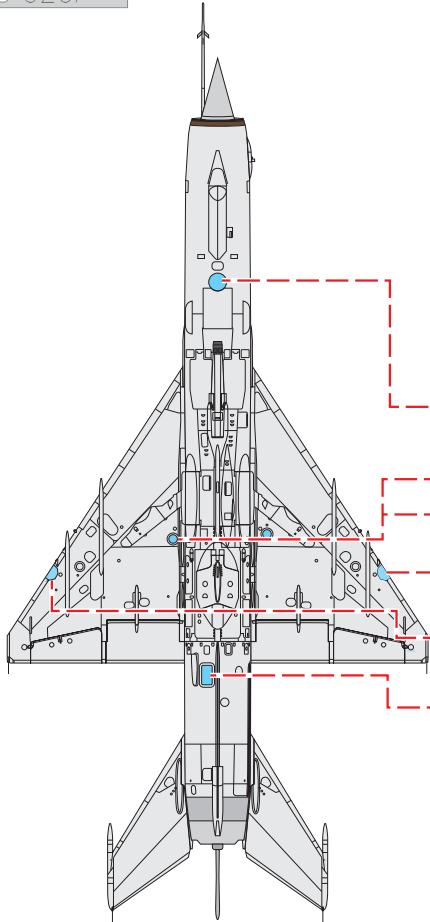
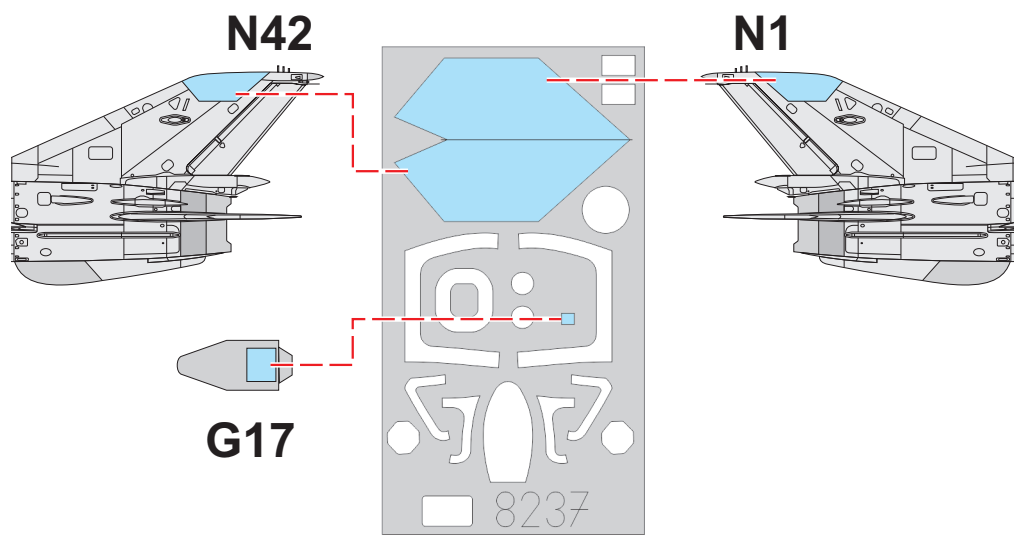
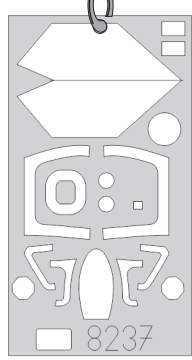

G14
G15
G11

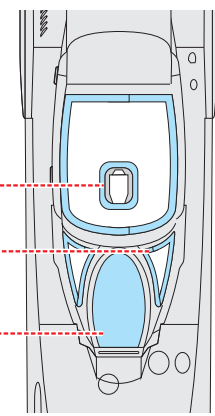
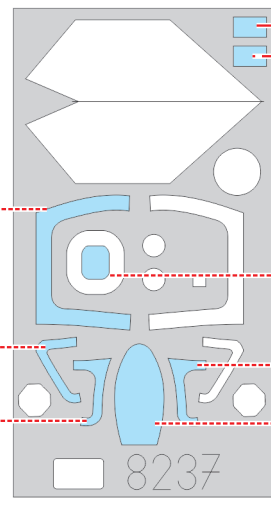
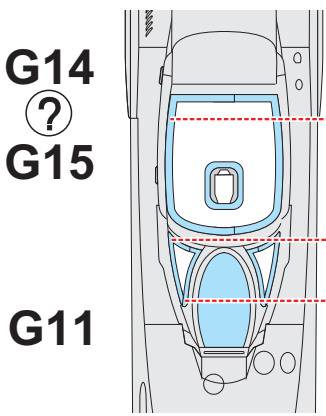

G14
G15
G11

A Vietnamese People's Army Air Force, 921st Fighter Regiment, 1968

This aircraft was flown by 921st Fighter Regiment „Sao Do” (Red Star) in 1968. The first examples of MiG-21PFM were delivered to this unit during this year. Some sources say that this particular MiG was flown by Nguyen Van Coc, a fighter ace credited with 9 kills. The b&w photos of this aircraft can be interpreted in various ways. One of the theories says that green splotches were sprayed on the upper sides. The splotches were not sharp-edged and the surrounding area was also covered by the thin layer of the green color. This gave this area light-green appearance. The canopy and antenna were left in natural metal finish.

Tento letoun byl používán v roce 1968 921. stíhacím plukem, nesoucím název Sao Do (Rudá hvězda). První MiGy-21PFM dostala tato jednotka právě v roce 1968. Některé prameny uvádějí, že s letounem létal Nguyen Van Coc, eso s devíti sestřely na kontě. Černobílé snímky umožňují různou interpretaci zbarvení letounu. Dle našich výzkumů stroj dostal na horní plochy kamuflážní nástřík složený ze zelených skvrn. Rozprach barvy při nanášení zbarvil okolí skvrn světle zeleně. Překryt kabiny a anténa na hřbetě trupu zůstaly bez nátěru v barvě kovu.

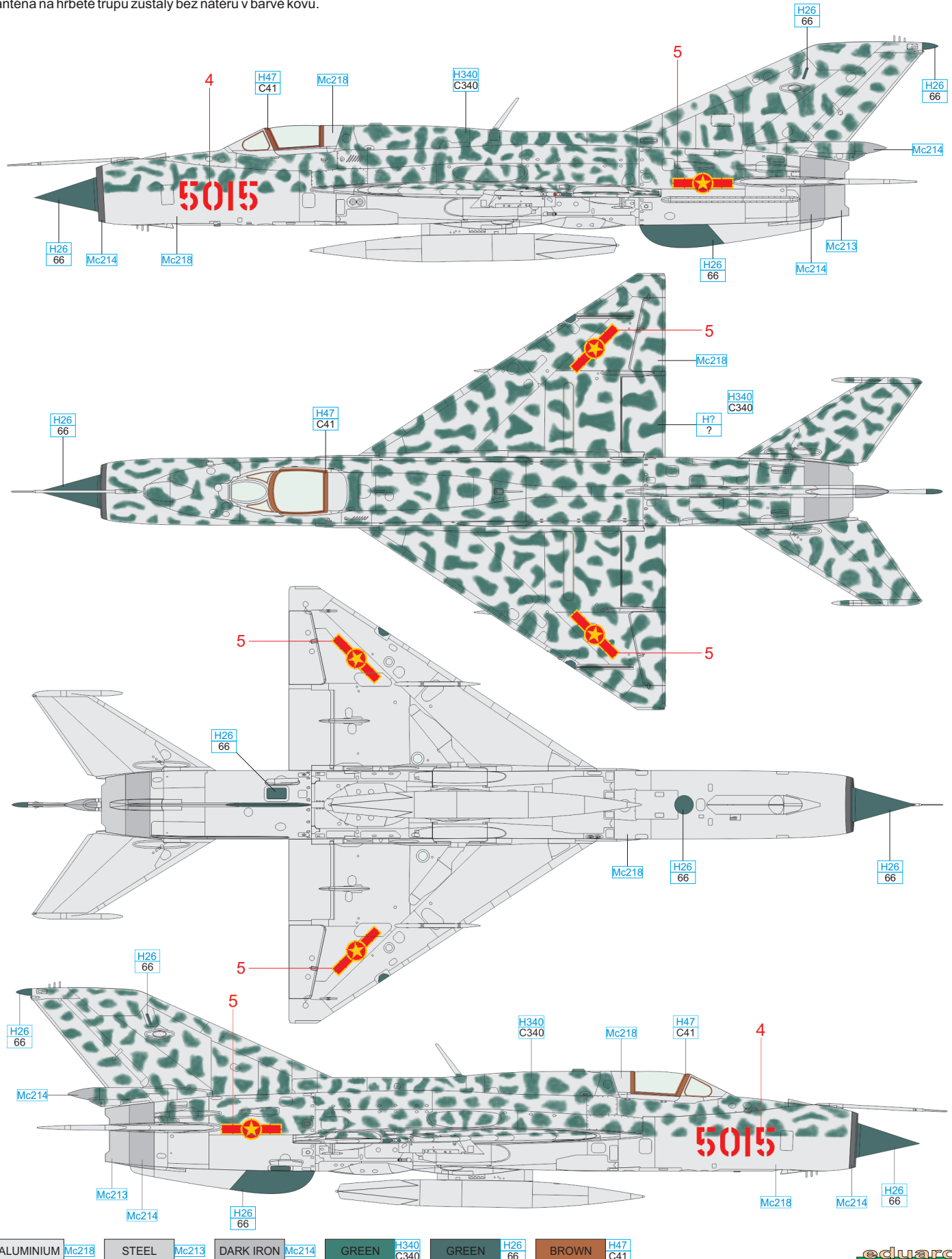

B Czechoslovak Air Force, 11th Fighter Regiment, Zatec AFB, March, 1991

The 7909 was delivered to Czechoslovakia on January 29, 1969. At the beginning had been assigned to 9. slp (9. stíhací letecký pluk – 9th Fighter Air Regiment), from April 1973 served with 1st Fighter Air Regiment. From December 1982 onwards was flown by 11th Fighter Air Regiment. It was rejected from the active service in March, 1991 and on March 20, 1991 to flown to the disposal site in Vodochody. The emblem of the Town of Zatec was painted on the nose, the yellow band on the tail identifies the aircraft determined to be rejected from the service. The aircraft remained unpainted.

Tento letoun byl do ČSSR dodán 29. ledna 1969. Nejdříve sloužil u 9. slp, od dubna 1973 pak u 1. stíhacího leteckého pluku. Od prosince 1982 jej používali piloti 11. stíhacího leteckého pluku v Žatci. K vyřazení stroje došlo v březnu 1991, dne 20. března byl přelétnut k uložení do Vodochod. Na levé straně přídě je erb města Žatce, žlutý pruh okolo zádě značil letouny určené k vyřazení a byl namalován těsně před odletem od jednotky. Povrch letounu zůstal v barvě materiálu.

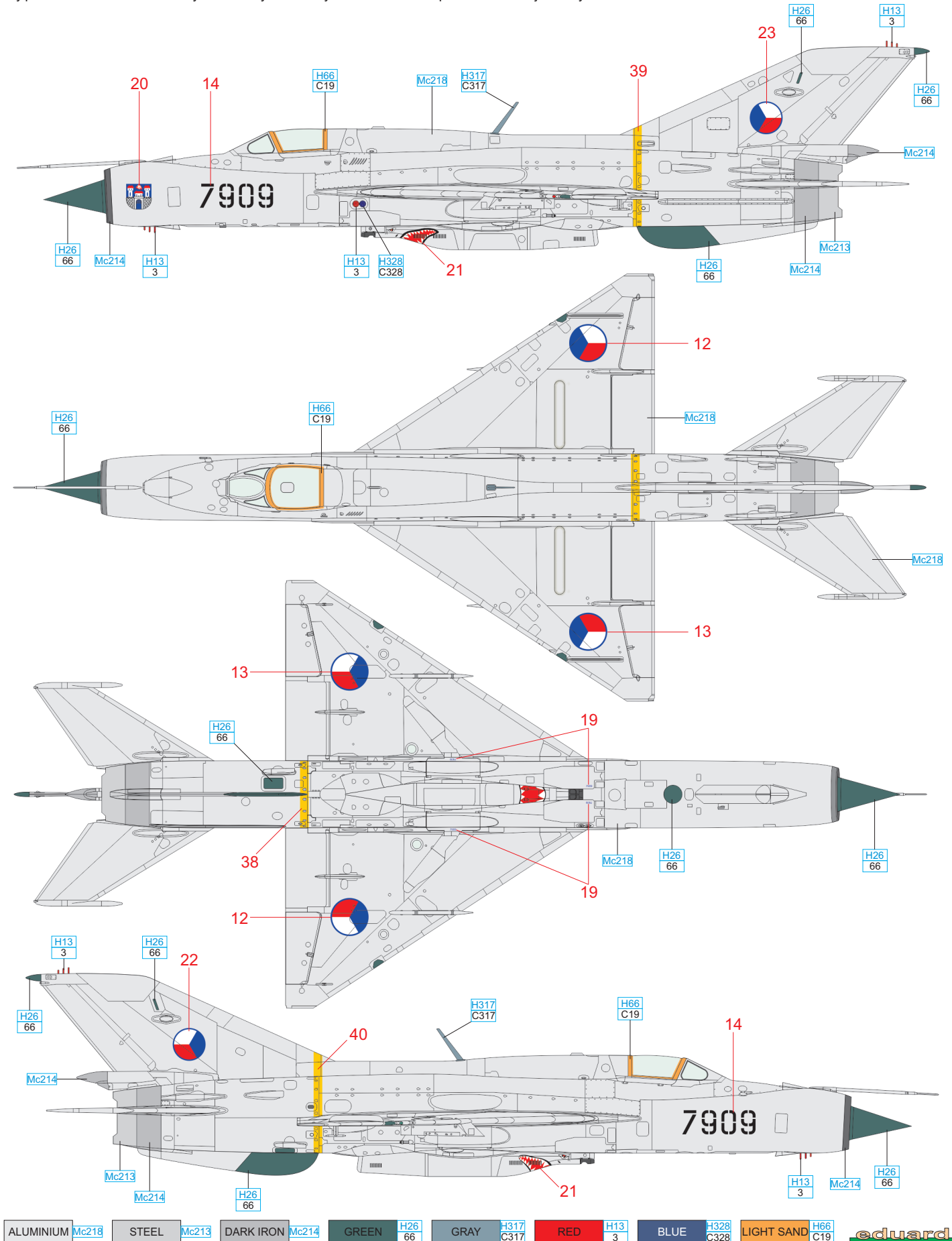

ALUMINIUM	Mc218	STEEL	Mc213	DARK IRON	Mc214	GREEN	H26 66	GRAY	H317 C317	RED	H13 3	BLUE	H328 C328	LIGHT SAND	H66 C19
-----------	-------	-------	-------	-----------	-------	-------	--------	------	-----------	-----	-------	------	-----------	------------	---------

C Barnaul Higher Air Force School, Kamen na Obi / Slavgorod airbases, Soviet Union, ca 1988

Three-digit numbers were used for aircraft flown by Air Force schools in Soviet Union. The White 105 served with Barnaul Higher Air Force School in late 80ties. The exact Regiment that flew this MiG is not known. It belonged either to 59. UAP (59th Training Air Regiment) based in Kamen na Obi AFB or to 96. UAP that used Slavgorod AFB as its home. The colorful camouflage was applied during the service in the School. Note the large area of the brown camouflage color under the white fuselage number, where the former two-digit number used by the frontline unit, the previous operator, was overpainted.

Třímístná trupová čísla byla v Sovětském svazu používána k označování letounů z leteckých škol. Tento stroj sloužil na sklonku 80. let minulého století v Barnaulském vyšším vojenském leteckém učilišti. Konkrétní uživatel není zcela znám. Patřil buď do 59. UAP (Školní letecký pluk) umístěného na letišti Slavgorod, nebo do 96. UAP, který používal letiště Kameň na Obi. Zajímavé zbarvení dostal letoun až u této jednotky. Pod trupovým číslem na přídi je vidět větší pole barvy, které zakrylo původní dvoumístné číslo z dob služby MiGu u bojové jednotky.

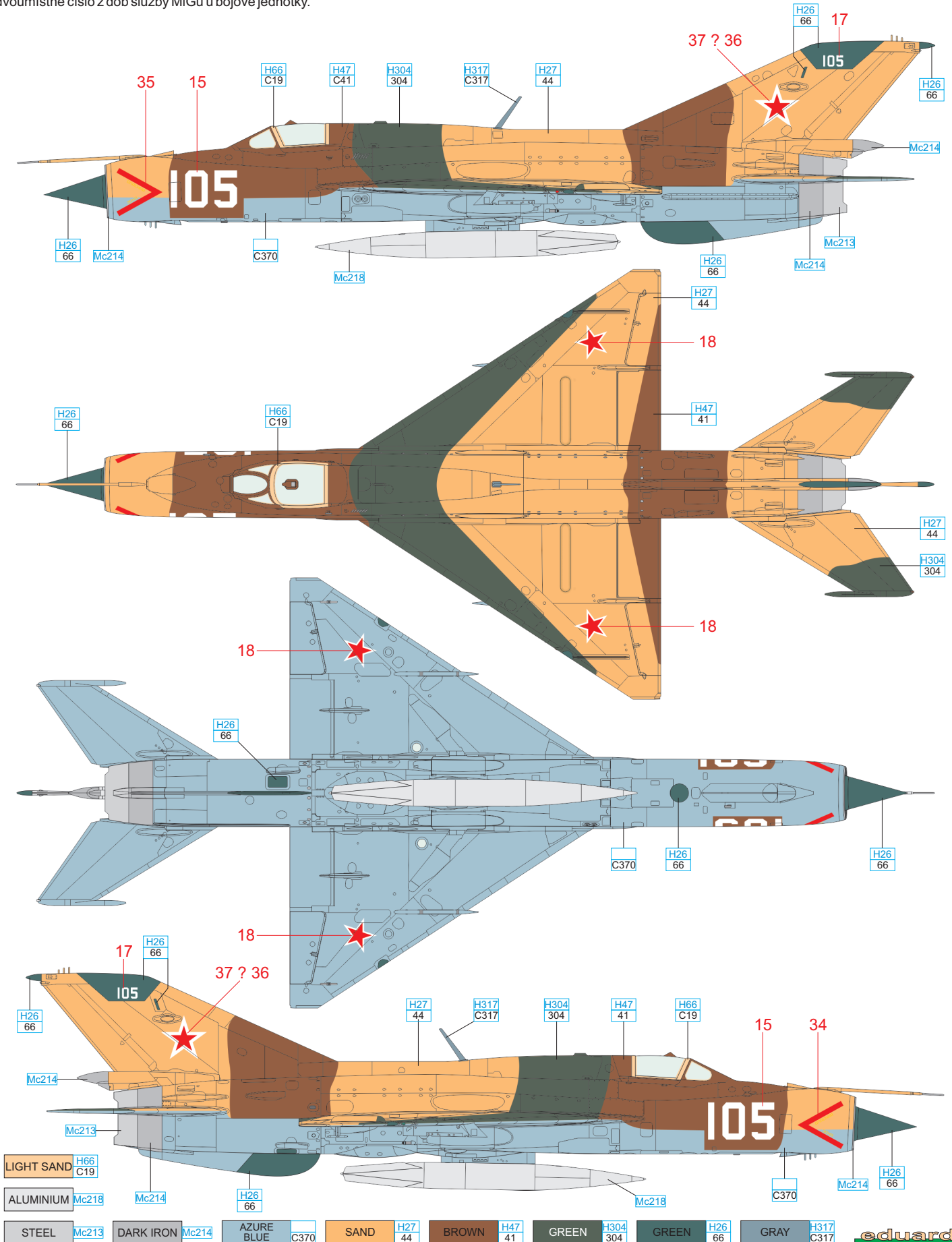

D Egyptian Air Force, Inshas airbase, early 80's

This aircraft is one of the few MiG-21PFMs flown by Egyptian Air Force after Six-Days War. Prior to this Arab – Israeli conflict the total of 235 various MiG-21s was delivered to Egypt, but about 10 only survived the war. Only the surprising Israeli aerial attack on Egyptian airbases on the very first day of the war on June 5, 1967 (Operation Moked) cost about 90 Egyptian MiG-21s. This particular MiG was delivered to Egypt sometimes around 1970 and took part in the US – Egyptian military exercise Bright Star in 1982.

Tento stroj je jedním z mála MiGů-21PFM, které létaly v Egyptě po ukončení Šestidenní války. Před tímto arabsko-izraelským konfliktem Egypt dostal celkem 235 MiGů-21 různých verzí, boje přečkalo však pouze okolo deseti letounů. Jen překvapivý útok izraelského letectva v první den války 5. června 1967 (operace Moked) přinesl Egyptu ztrátu odhadovanou na 90 MiGů-21. Do Egypta se tento letoun dostal někdy okolo roku 1970. Vyfotografován byl při společném egyptsko-americkém cvičení Bright Star, jež proběhlo v roce 1982.

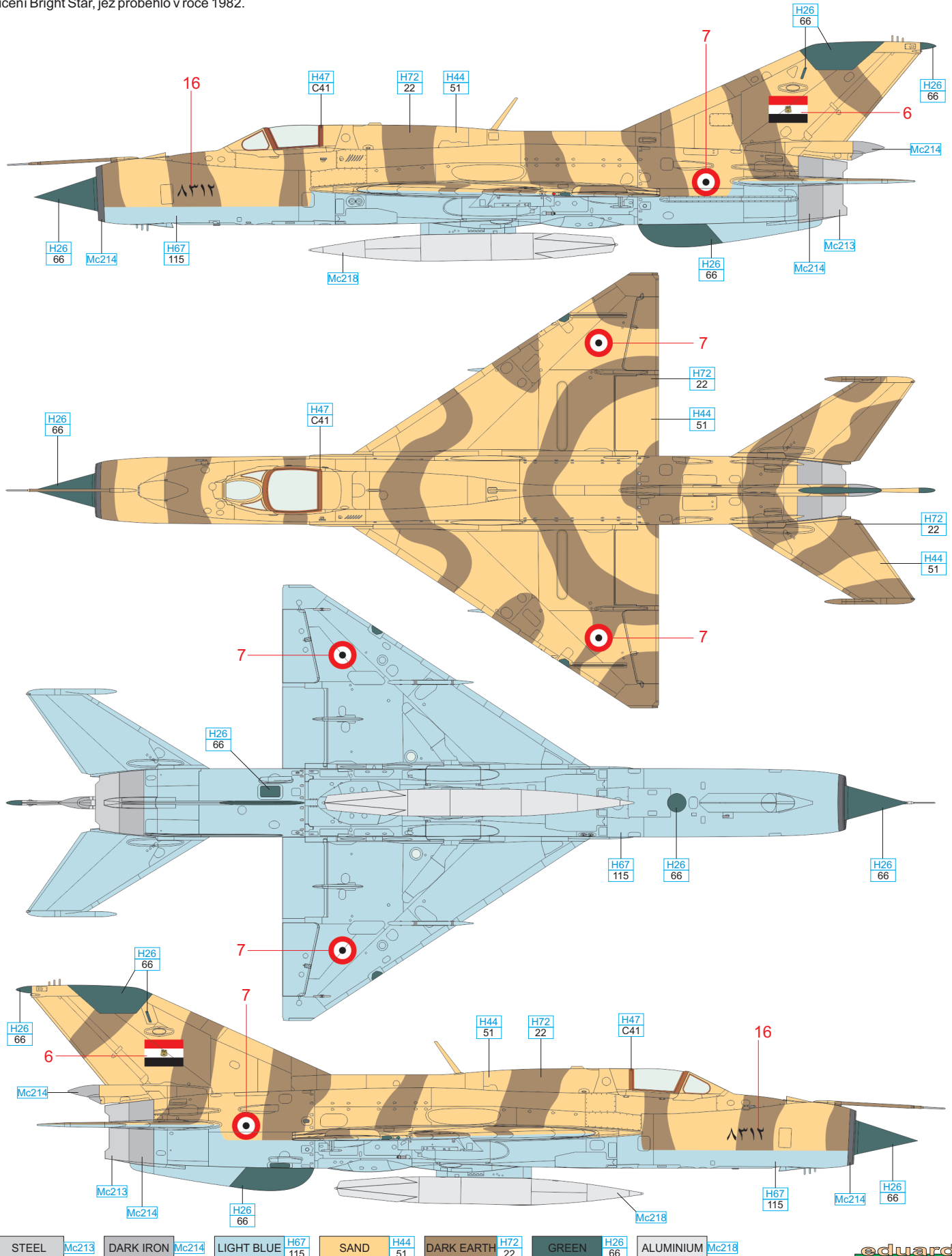

E Polish Air Force, 1st Squadron of 62nd Fighter Regiment, Poznan – Krzesiny AB, 1994

This aircraft had been delivered to Poland on April 5, 1968 and served with 34. Pułk Lotnictwa Myśliwskiego (34th Fighter Air Regiment). This profile depicts the 6910 how it looked during the service with 62. PLM. The tail marking was applied in connection with 40th anniversary of the unit establishment (1954 – 1994). In 1995 the unit designation was changed to 3. PLM and according to this the number 62 in the unit badge on the A/C nose was replaced with the new one. This PFM was armed with GP-9 gun pod and Monsun rack for two R-3S missiles. The aircraft was oversprayed with thin layer of aluminium coat.

Tento letoun byl do Polska dodán 5. dubna 1968 a jeho prvním působištěm byl 34. Pułk Lotnictwa Myśliwskiego (stíhací letecký pluk). V této podobě jej používal 62. PLM. Výroční zbarvení připomíná 40. let existence jednotky (1954 – 1994). V roce 1995 byl pluk přeznačen na 3. PLM a v souvislosti s touto změnou se také změnilo číslo ve znaku na předětuonu. Letoun nosil kanonové pouzdro GP-9 a závěsníky Monsun pro zavěšení dvou raket R-3S pod každý křídelní pylon. Povrch letounu byl přestříkán aluminiovou barvou.



LEVÝ PYLON LEFT PYLON



PRAVÝ PYLON RIGHT PYLON



APU-7

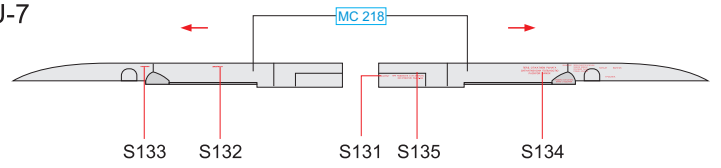
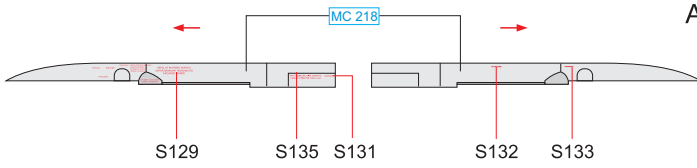

APU-13

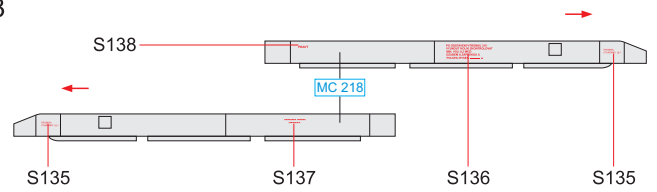
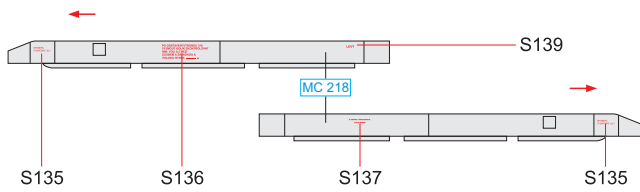

APU-13

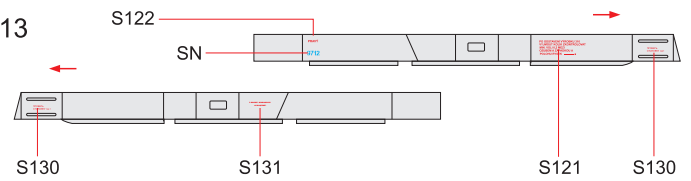
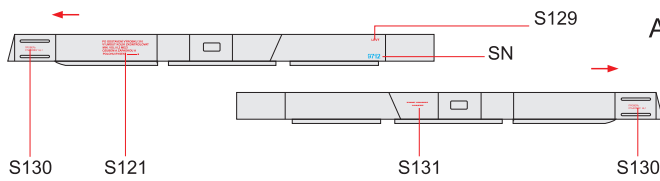

PODRUPOVÝ PYLON FUSELAGE PYLON

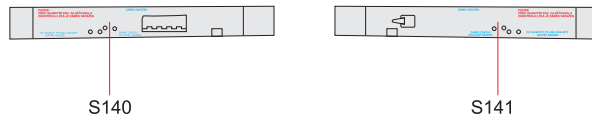

RS-2US

TOP

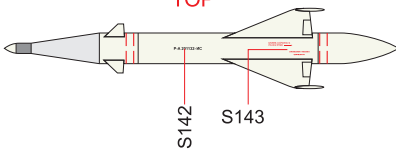

S-24

TOP

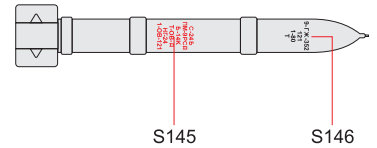

KANONOVÝ KONTEJNER GP-9 GUN POD GP-9

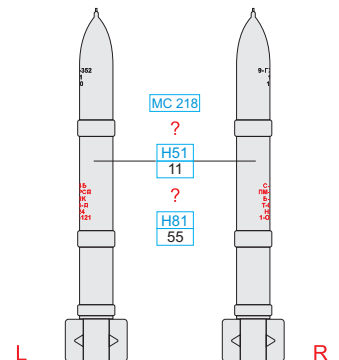
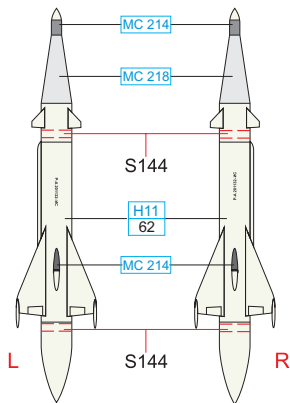
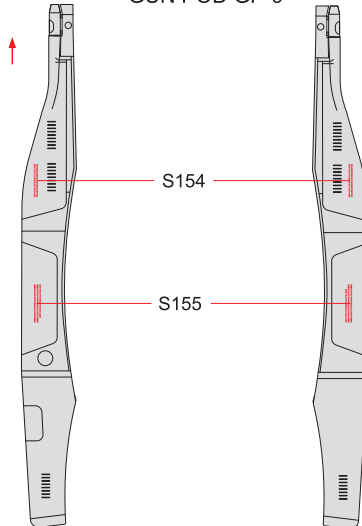

R-3S

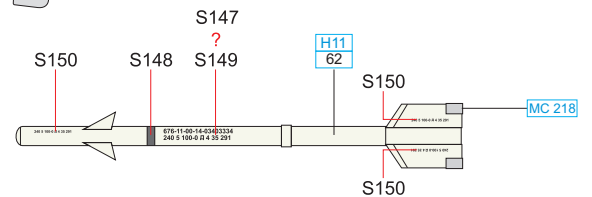
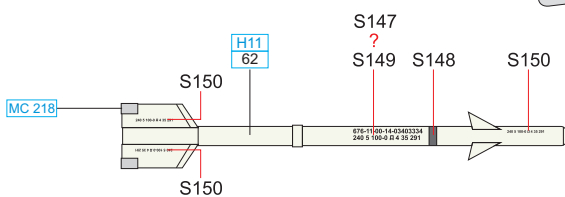

R-3R

