

A6M2 Zero Type 21

eduard

1/48 Scale Plastic Model Kit

WEEKEND
edition



item No. 84189

The Mitsubishi Zero became symbol of the Japanese air power during WWII. The nimble and agile fighter had upper hand over US aircraft at early stages of the war in the Pacific theatre, but was gradually losing to its newer opponents.

The Japanese aircraft industry was oriented towards the production of aircraft built under foreign licenses in the 1920s and early 1930s. However, the armed forces, especially the Navy, with regard to the specifics of the Chinese and Pacific battlefields, came up with requirements that foreign aircraft designs did not offer.

Due to that, Mitsubishi Heavy Industries developed Type 96 naval fighter aircraft, better known as the A5M „Claude“. The head of the design team was a young Japanese engineer, Jirō Horikoshi. With an engine that lacked some power, he managed to design a light and fast fighter with a fixed landing gear, which had no comparison in the world regarding maximum speed.

In October 1937, Mitsubishi and Nakajima were approached to develop prototype 12-shi Carrier-based Fighter. The requirements were so extreme and in some cases contradictory that the two design teams investigated whether they could be less stringent. Nakajima eventually withdrew from the project, while the criteria for the prototype were even rised based on experience on the Chinese battlefield.

The Horikoshi's team managed to meet the technical specifications not only thanks to the aerodynamic design and a new type of light alloy used for the aircraft's skin, but also thanks to the Nakajima Sakae 11 engine. During the flight tests, the wing surface suffered cracking during overload and aileron control during high-speed maneuvers had to be addressed. The new fighter had a powerful armament of two cannons and two machine guns, extremely long range (over 1,800 km) and excellent maneuverability. The new fighter reached impressive top speed of 533 km/h at an altitude of 4,550 m. On the other side, it lacked armor and other protective features and its structural speed limit was just 600 km/h.

Surprising Zero

The new aircraft entered service in 1940 powered with 940 hp engine Sakae 12 and received the official designation Rei shiki Kanjō sentōki (Type 0 carrier fighter), with the „zero“ being derived from the imperial year 2600 (1940). Japanese pilots usually abbreviated it as „Rei-Sen“. That was also the origin of the name „Zero“ often used by Allied pilots instead of the official code name, derived from the male name „Zeke“. As part of the Navy's system, the new machine was given the type designation A6M, where A6 meant that it was the sixth type of carrier fighter to enter service, and M stood for the Mitsubishi company name. Zeros, specifically the A6M2 Type 11, had been successfully deployed on the Chinese battlefield since the summer of 1940, but their existence eluded Western intelligence because no one wanted to believe reports from China that suggested the Japanese had a world-class fighter. Further modifications to its design were made during 1941, creating the A6M2 Type 21.

Total of 740 A6M2 aircraft were produced by Mitsubishi by June 1942 with additional 800 delivered by Nakajima by February 1944. The gun armament was improved and variants with the ammunition supply of up to 150 rounds could be used on the Type 21.

Further development

The Nakajima company produced 254 A6M2 fighters in the float version from December 1941 to July 1943. Its prototype flew on December 8, 1941, and the design featured a pylon with a central float, a solution not used in any country up to that time. The A6M2-N fighters were mainly used to defend naval bases.

Mitsubishi started production of Zero in 1942 powered by the Sakae 21 engine with a two-stage compressor and maximal output 1,130 hp. The wingspan was shortened and the modified version was designated A6M3 Type 32. The speed limit was raised but the range was reduced, therefore only 340 were produced from June to December 1942. The Allies at first believed that this was a new type of fighter. Therefore, they gave it a separate codename „Hap“, later changed to „Hamp“.

After the Allied landings on Guadalcanal, the IJN fighter units came up with a request for a Zero with the Sakae 21 engine, but with the range comparable to A6M2.

Designers at Mitsubishi company modified the wing including design of inner fuel tanks. The wing looked similar to the one of Type 21, but the range was even 100 miles longer. This version was designated A6M3 Type 22, while the aircraft with extended gun barrels were designated Type 22a.

Another version was the Type 52 with shortened wing-span. Production began in early 1944 and Type 52 was very similar to the Type 22a. Soon the exhaust system was modified to help increase the speed of the aircraft. The Type 52a had enlarged cannons ammunition supply of 125 rounds per weapon. The Type 52b saw the installation of a 13.2 mm machine gun on the right side of the fuselage. For the Type 52c, two 13.2 mm machine guns were fitted in the wing and the 7.7 mm machine gun on the left side of the fuselage was deleted. Eight racks for small-calibre bombs or rockets were added to the wing. For night-fighting purposes, a forward-firing cannon in the fuselage behind the cockpit was installed in some Zeros, designated as A6M5-S. In total, Mitsubishi and Nakajima produced more than 5,000 A6M5s.

The last combat-deployed variant of the Zero was an aircraft with a reinforced structure for dive bomber purpose (Type 62). Later, the A6M7 was equipped with the Sakae 31 engine producing 1,130 hp. This fighter-bomber variant was designated as Type 63.

Several hundred aircraft were also modified from the A6M2 Zero Type 21 and A6M5 Type 52 to the two-seaters A6M2-K and A6M5-K, produced from January 1943 and May 1944 respectively.

The kit: A6M2 Zero Type 21

The Type 21 was direct development of the Type 11. There were several changes, the most visible of them being folding wing tips to enable easier handling on the deck of aircraft carriers. With the A6M2 Type 21 modified this way, Japan entered the war with the US and other Western nations. Mitsubishi needed to produce other aircraft in addition to the Zero, so the Nakajima company also began licensed production in late 1941.

ATTENTION



UPOZORNĚNÍ



ACHTUNG



ATTENTION



注意



Carefully read instruction sheet before assembling. When you use glue or paint, do not use near open flame and use in well ventilated room. Keep out of reach of small children. Children must not be allowed to suck any part, or pull vinyl bag over the head.



Před započítím stavby si pečlivě prostudujte stavební návod. Při používání barev a lepidel pracujte v dobře větrané místnosti. Lepidla ani barvy nepoužívejte v blízkosti otevřeného ohně. Model není určen malým dětem, mohlo by dojít k požití drobných dílů.

INSTRUCTION SIGNS * INSTR. SYMBOLS * INSTRUKTION SINNBILDEN * SYMBOLES * 記号の説明

OPTIONAL
VOLBABEND
OHNOUSAND
BROUSITOPEN HOLE
VYVRTAT OTVORSYMETRICAL ASSEMBLY
SYMETRICKÁ MONTÁŽREMOVE
ODŘÍZNOUTREVERSE SIDE
OTOČITAPPLY EDUARD MASK
AND PAINT
POUŽIT EDUARD MASK
NABARVITPLEASE, CHECK THE LATEST VERSION OF THE INSTRUCTION ON www.eduard.com

PARTS



DÍLY



TEILE



PIÈCES



部品

PLASTIC PARTS

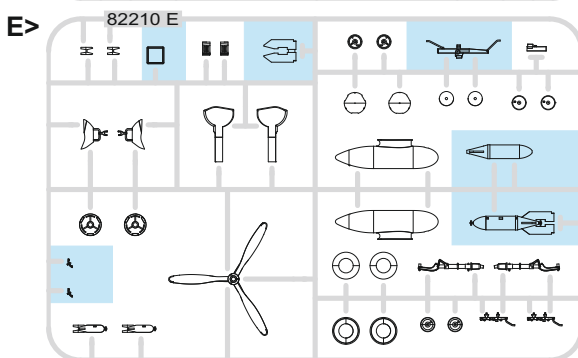
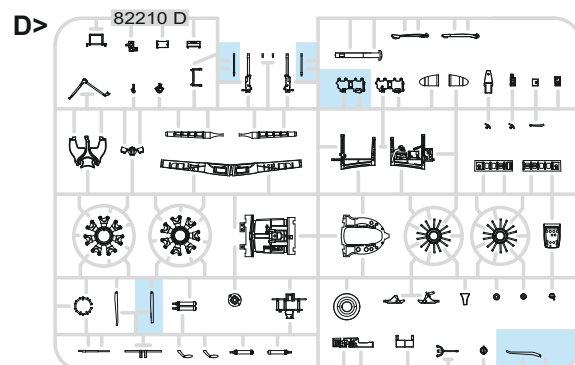
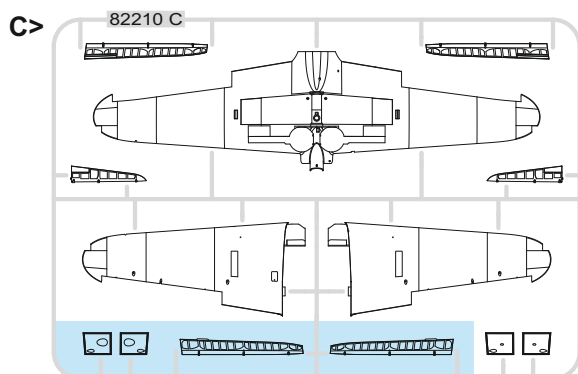
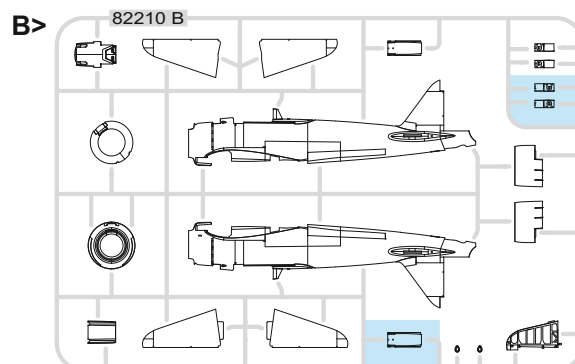
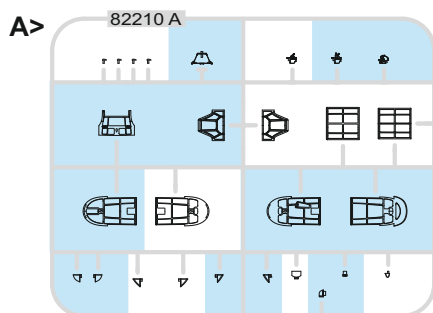

-Parts not for use. -Teile werden nicht verwendet. -Pièces à ne pas utiliser. -Tyto díly nepoužívejte při stavbě. - 使用しない部品

COLOURS



BARVY



FARBEN



PEINTURE



色

GSI Creos (GUNZE)		
AQUEOUS	Mr.COLOR	
H2	C2	BLACK
H6	C6	GREEN
H8	C8	SILVER
H11	C62	FLAT WHITE
H12	C33	FLAT BLACK
H24	C58	ORANGE YELLOW
H25	C34	SKY BLUE
H47	C41	RED BROWN
H58	C351	INTERIOR GREEN
H59	C15	I/JN GREEN
H63	C57	METALLIC BLUE GREEN
H70	C60	GRAY
H77	C137	TIRE BLACK
H90	C47	CLEAR RED

GSI Creos (GUNZE)		
AQUEOUS	Mr.COLOR	
H93	C50	CLEAR BLUE
H324	C324	LIGHT GRAY
H336	C336	HEMP
H340	C340	FIELD GREEN
H417	C117	RLM76 LIGHT BLUE
	C125	COWLING COLOR
	C131	RED BROWN
Mr.METAL COLOR		
MC214		DARK IRON
MC218		ALUMINIUM
MC219		BRASS
Mr.COLOR SUPER METALLIC		
SM201		SUPER FINE SILVER

1 = H58
C351 - MARKINGS **A**:**B**
H58
C340 - MARKINGS **C**:**D**
H12
C33 - MARKINGS **A**:**B**
H12
C33 - MARKINGS **C**:**D**
H12
C33 - MARKINGS **A**:**B**
H12
C33 - MARKINGS **C**:**D**

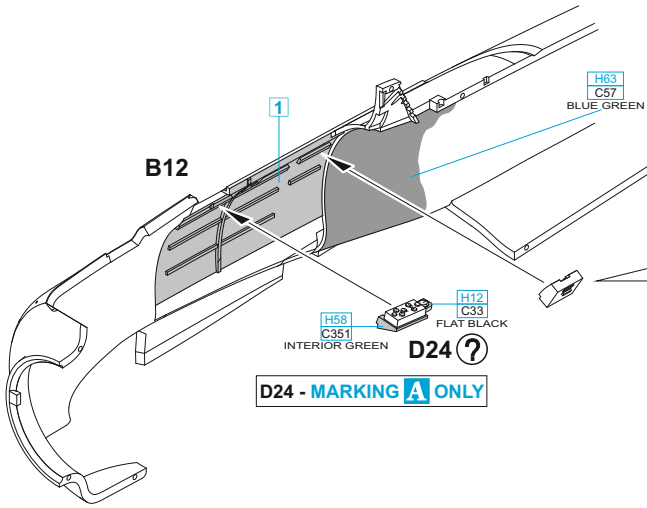

D24 - MARKING A ONLY

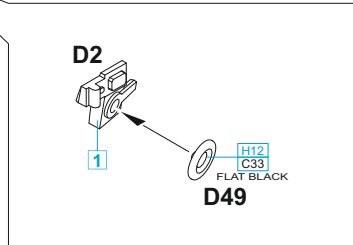
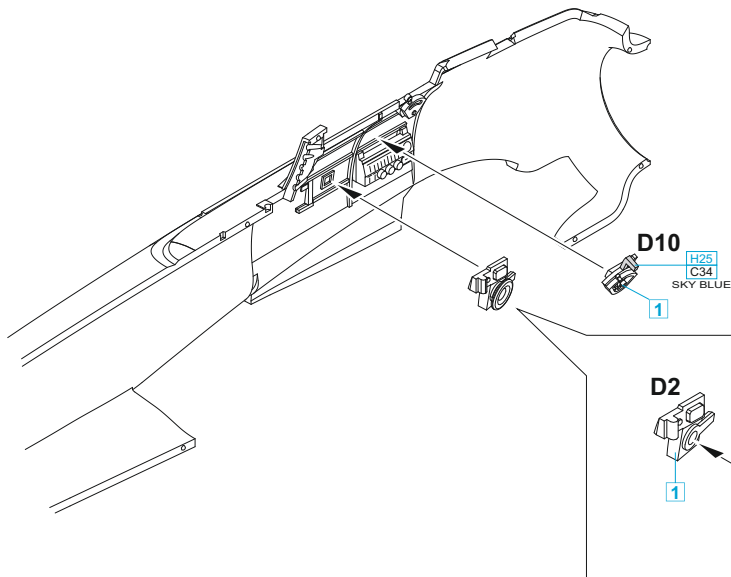
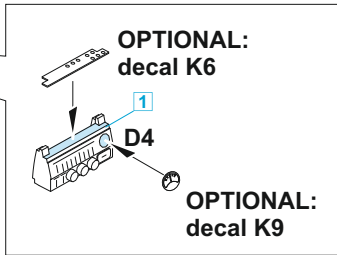
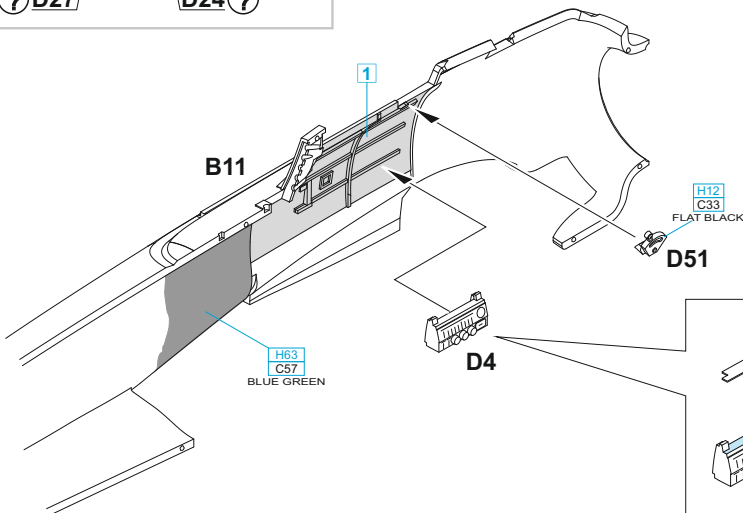
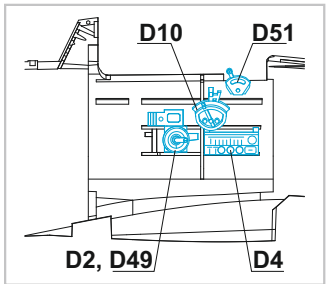
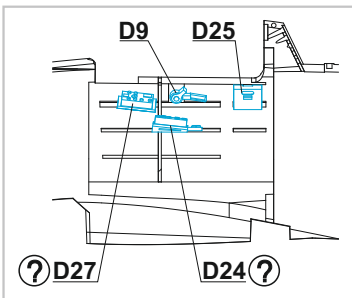
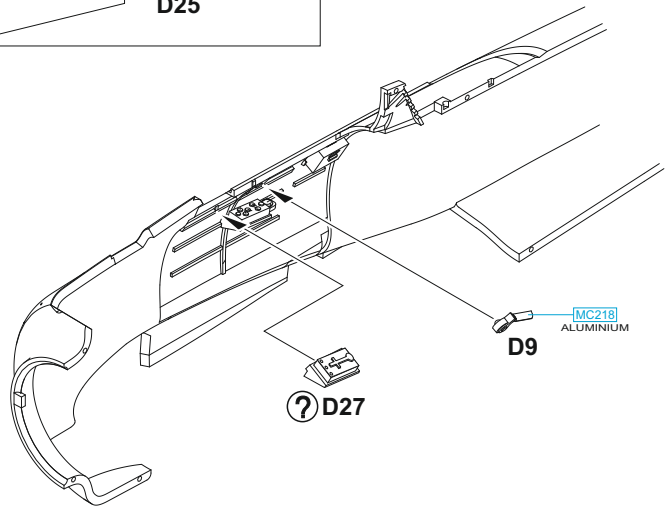
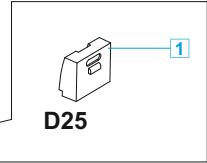

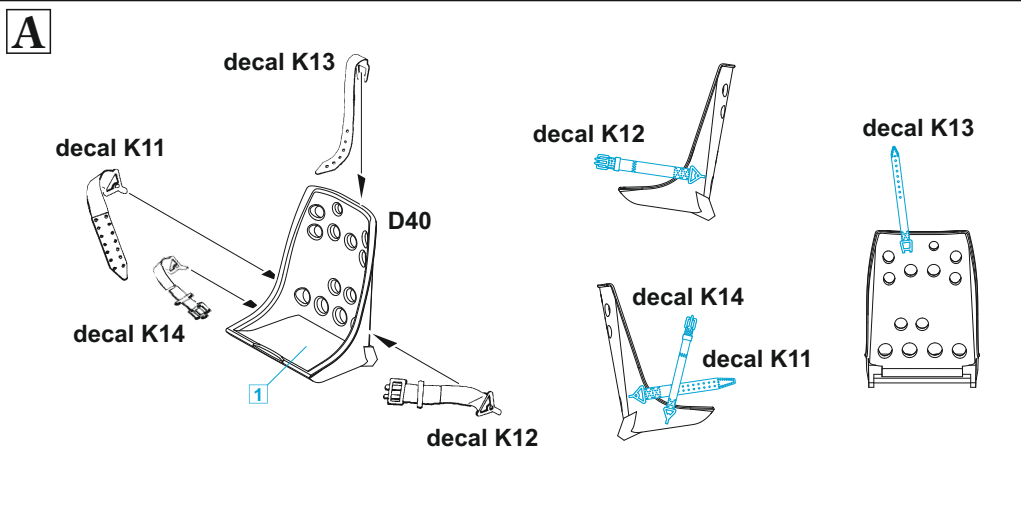

2	H58 - MARKINGS A; B
	C351 - INTERIOR GREEN
1	H12 - MARKINGS C; D
	C33 - FLAT BLACK

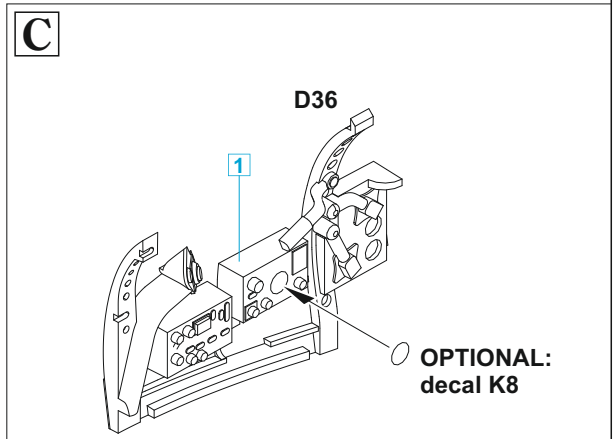
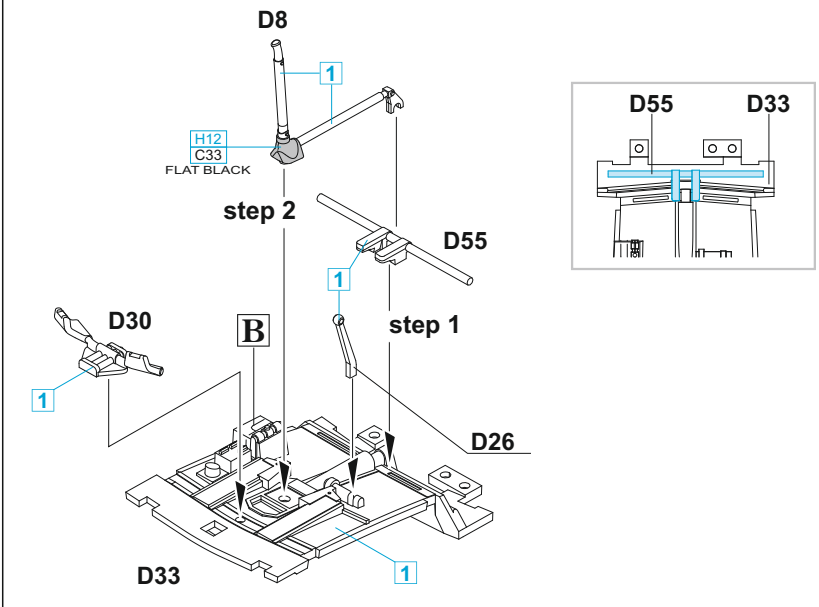
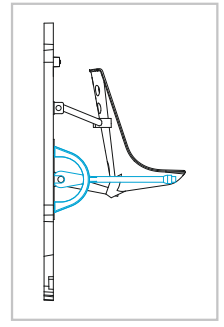
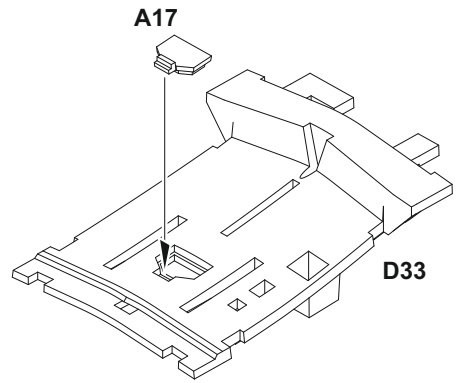
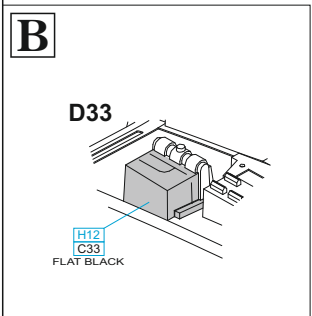
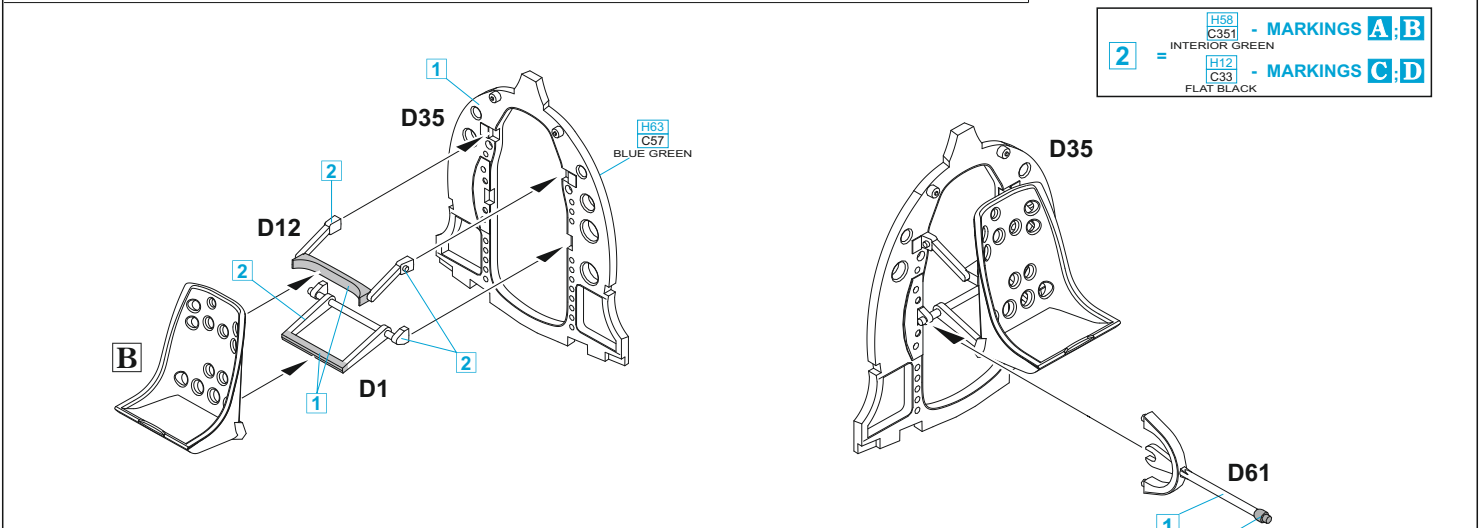

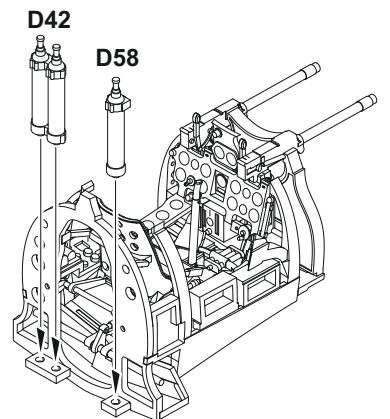
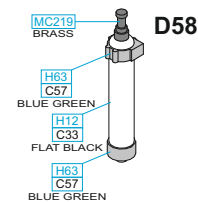
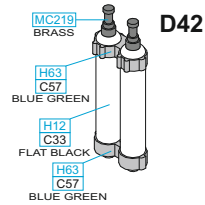
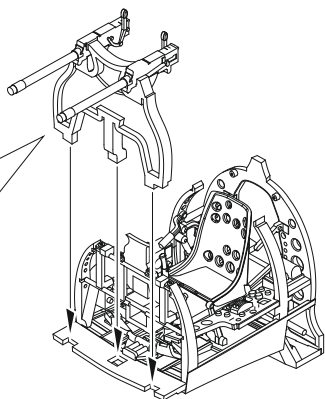
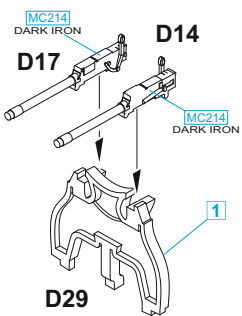
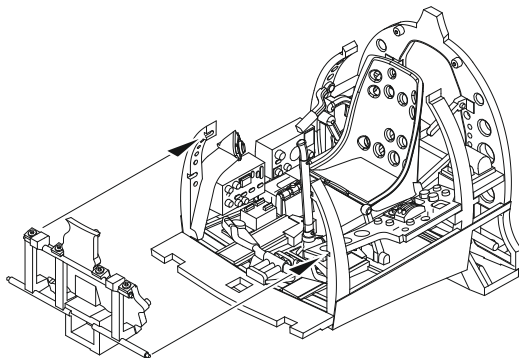
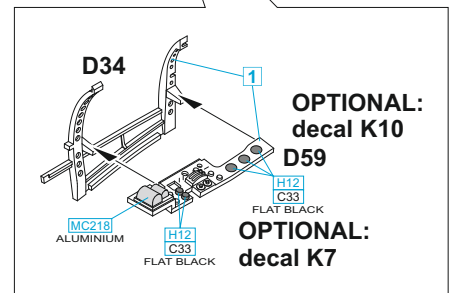
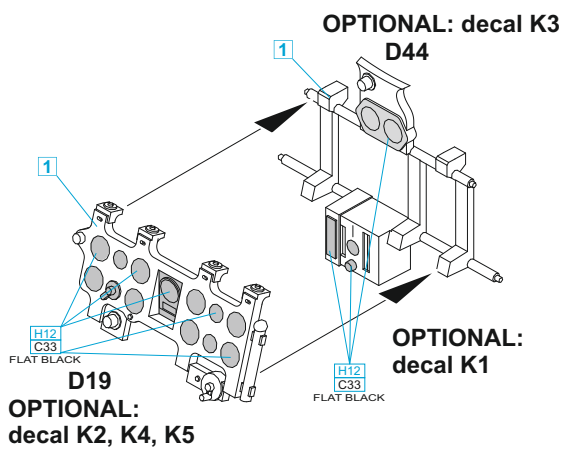
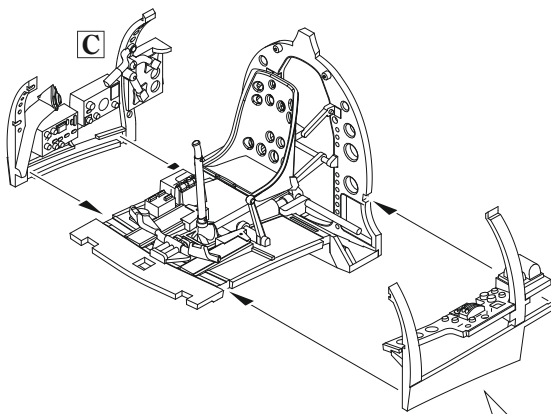
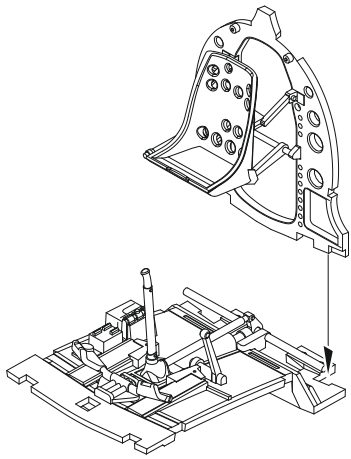

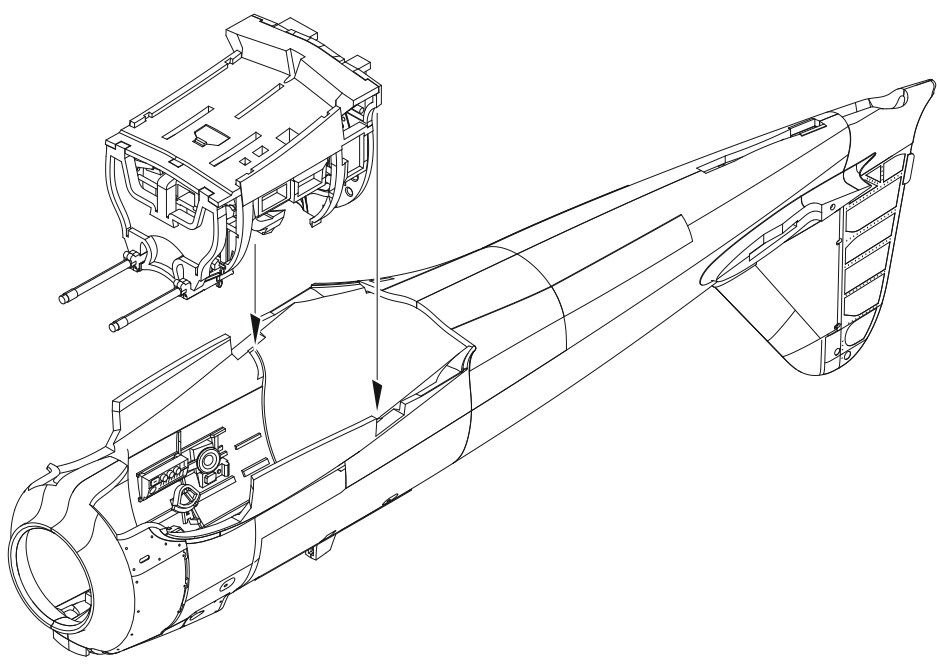
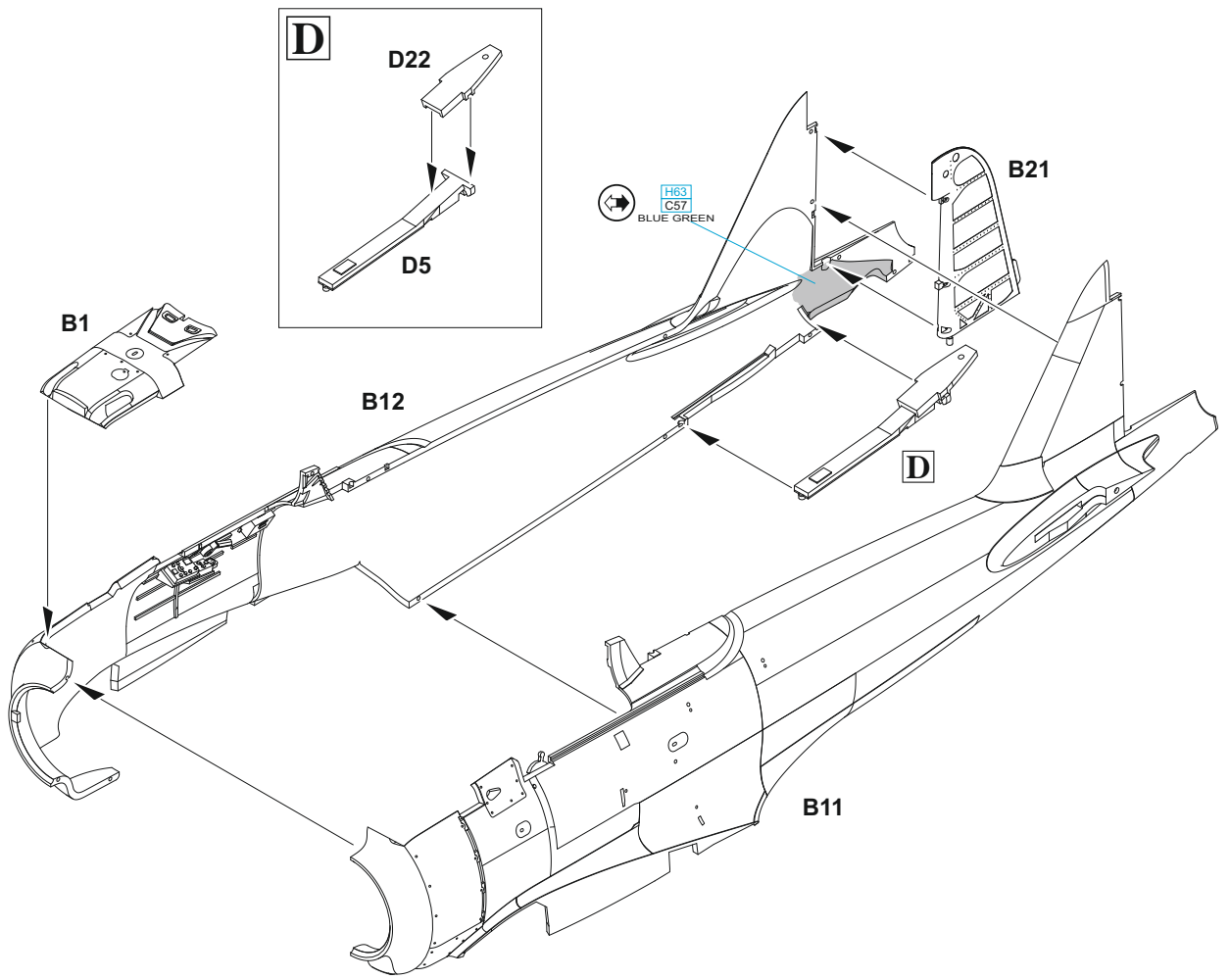

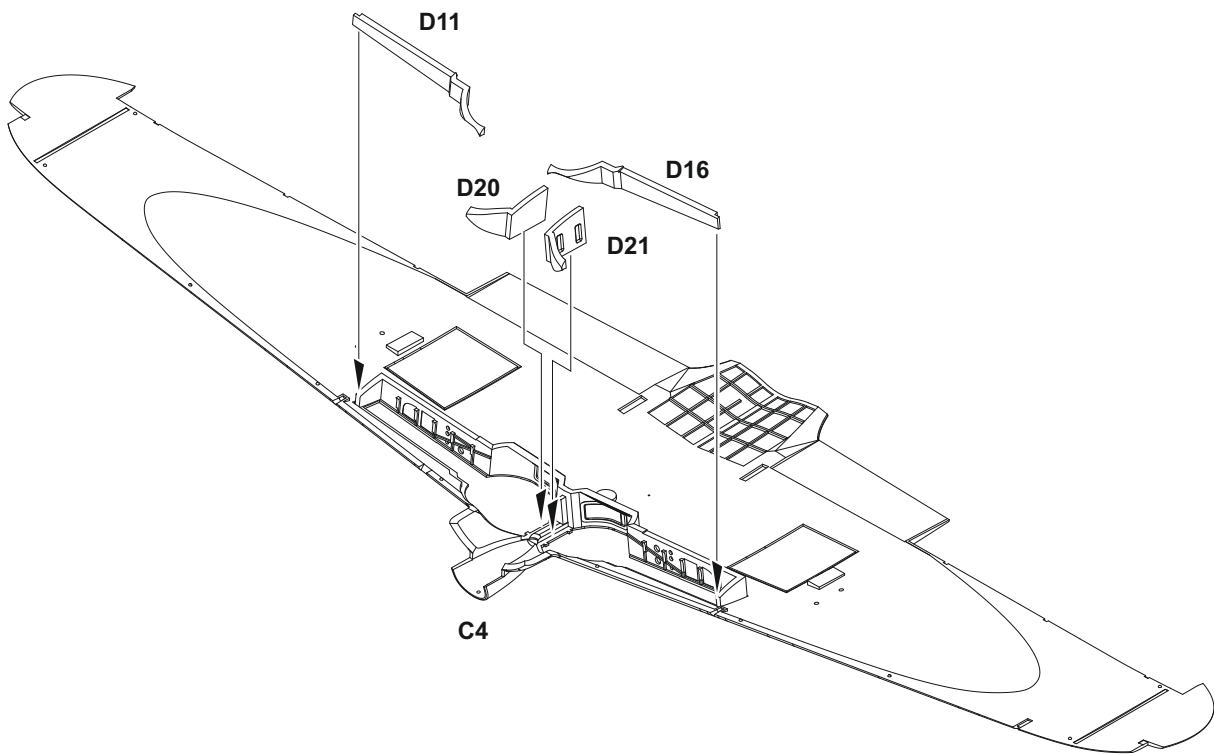
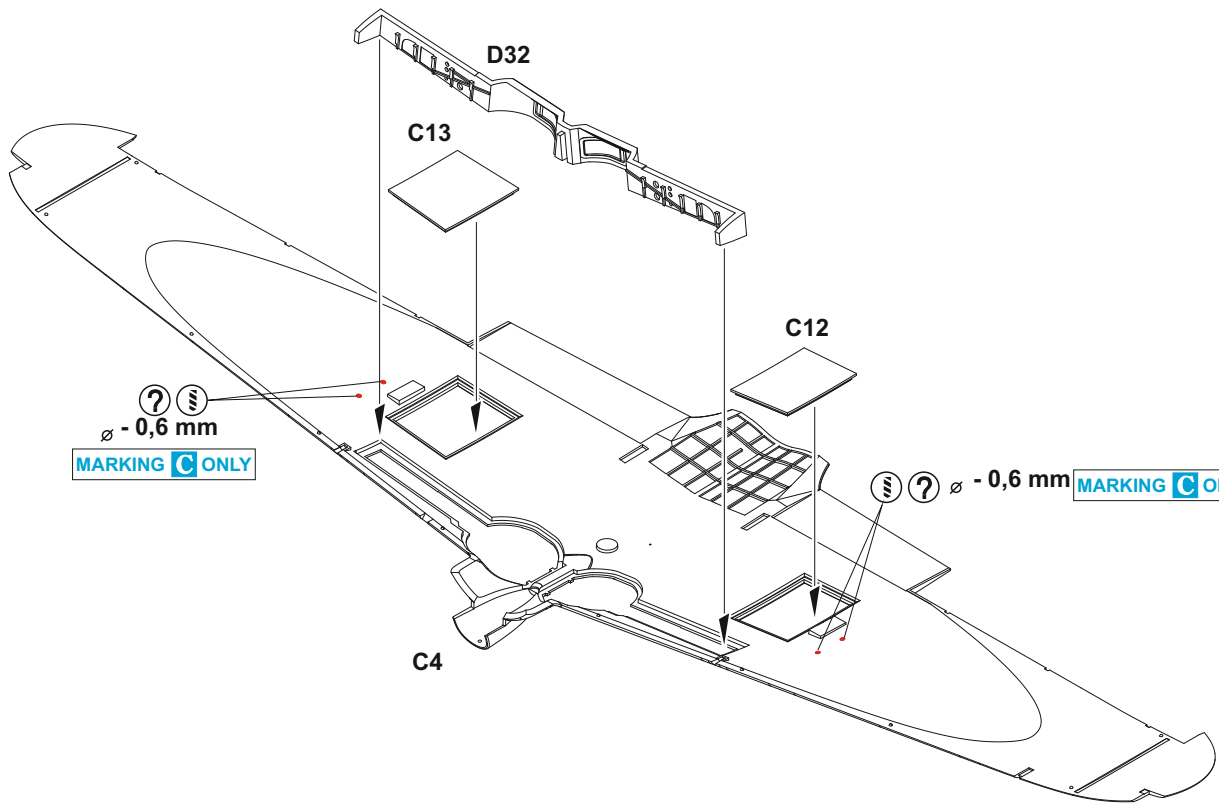

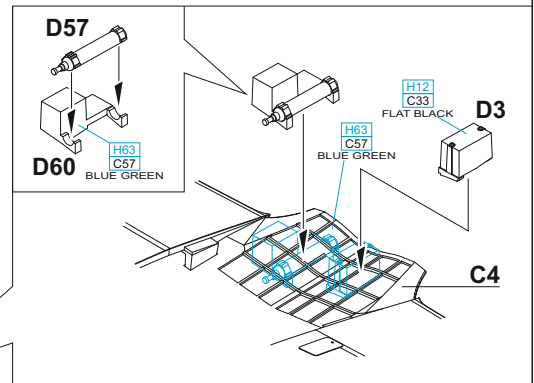
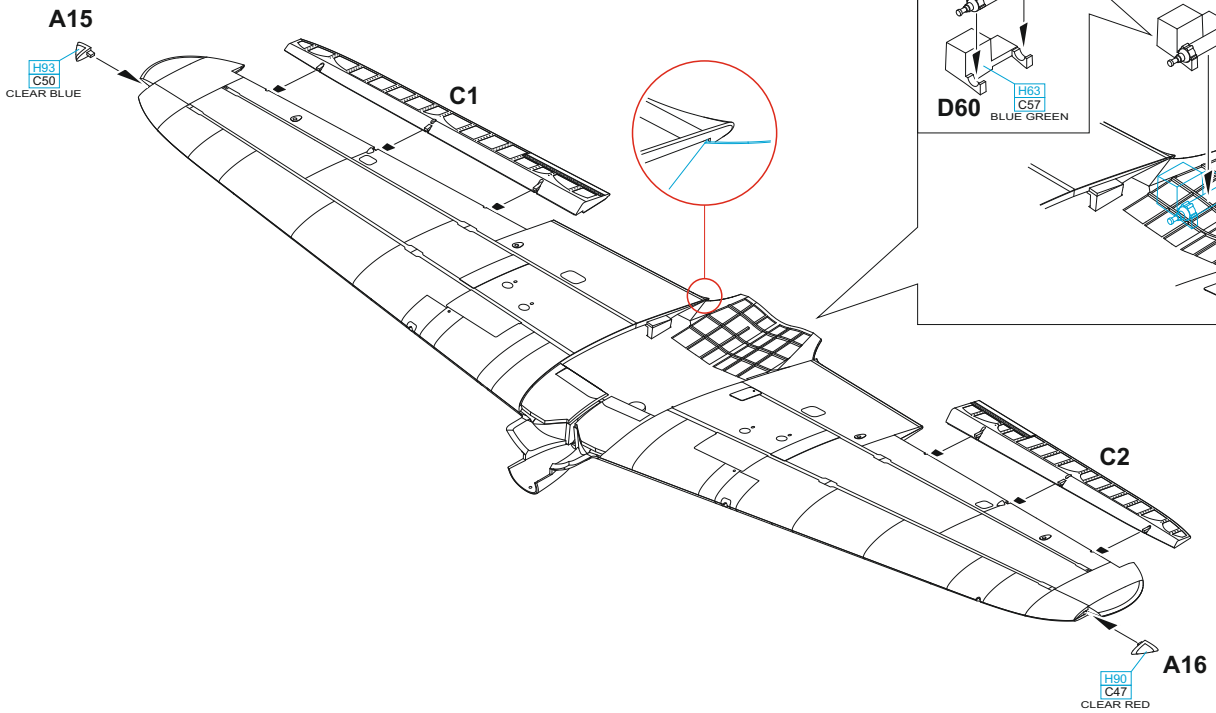
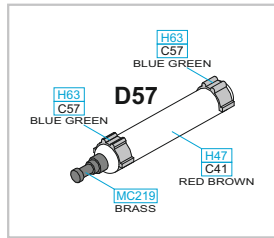
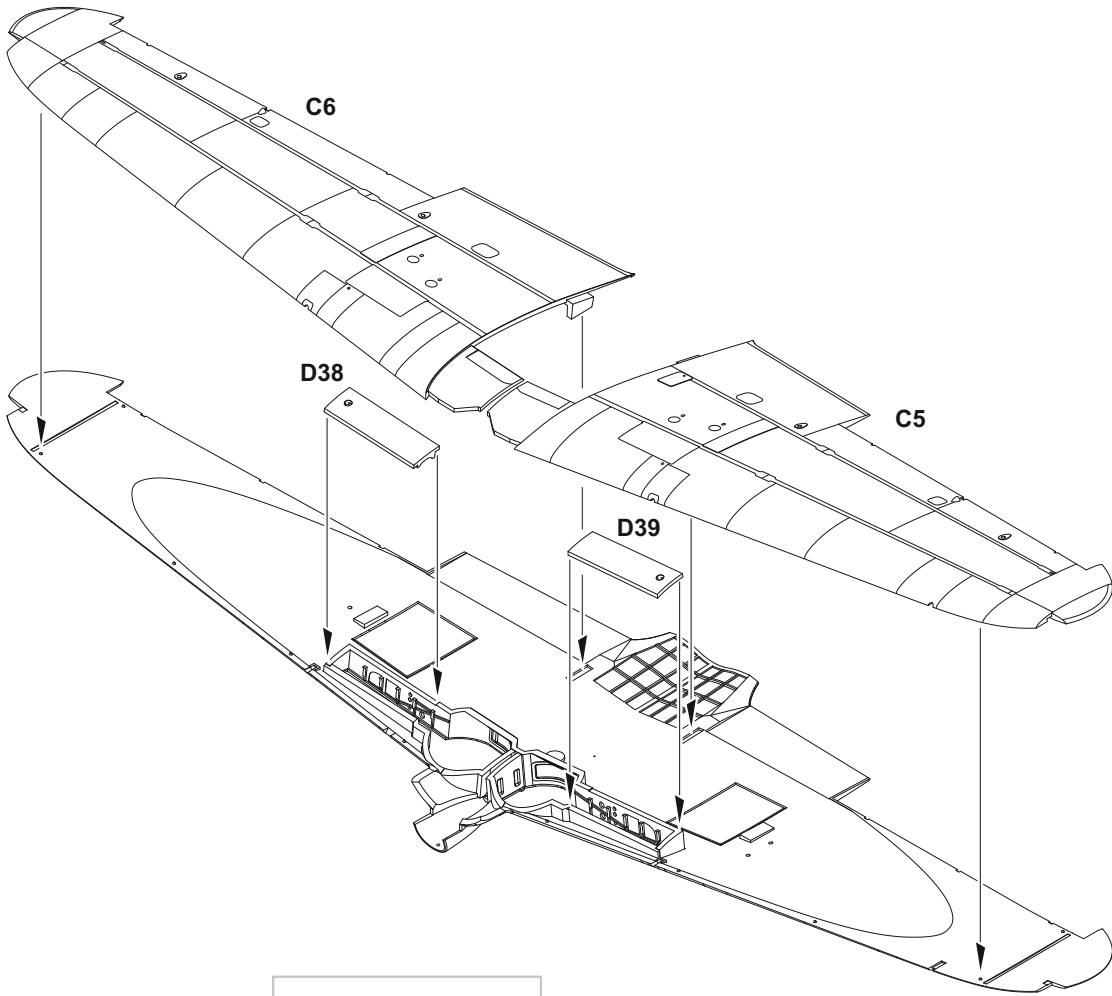

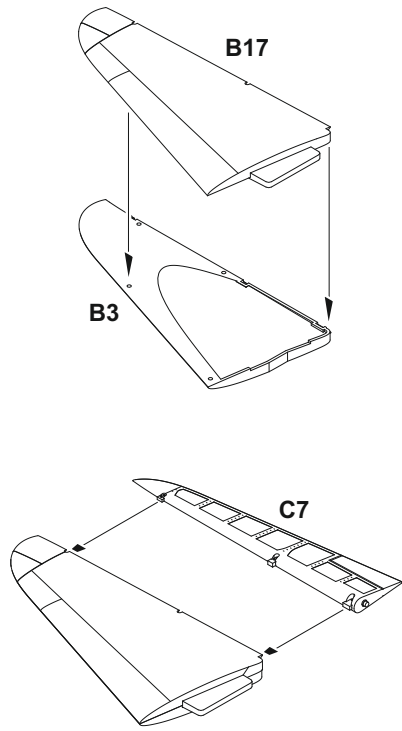
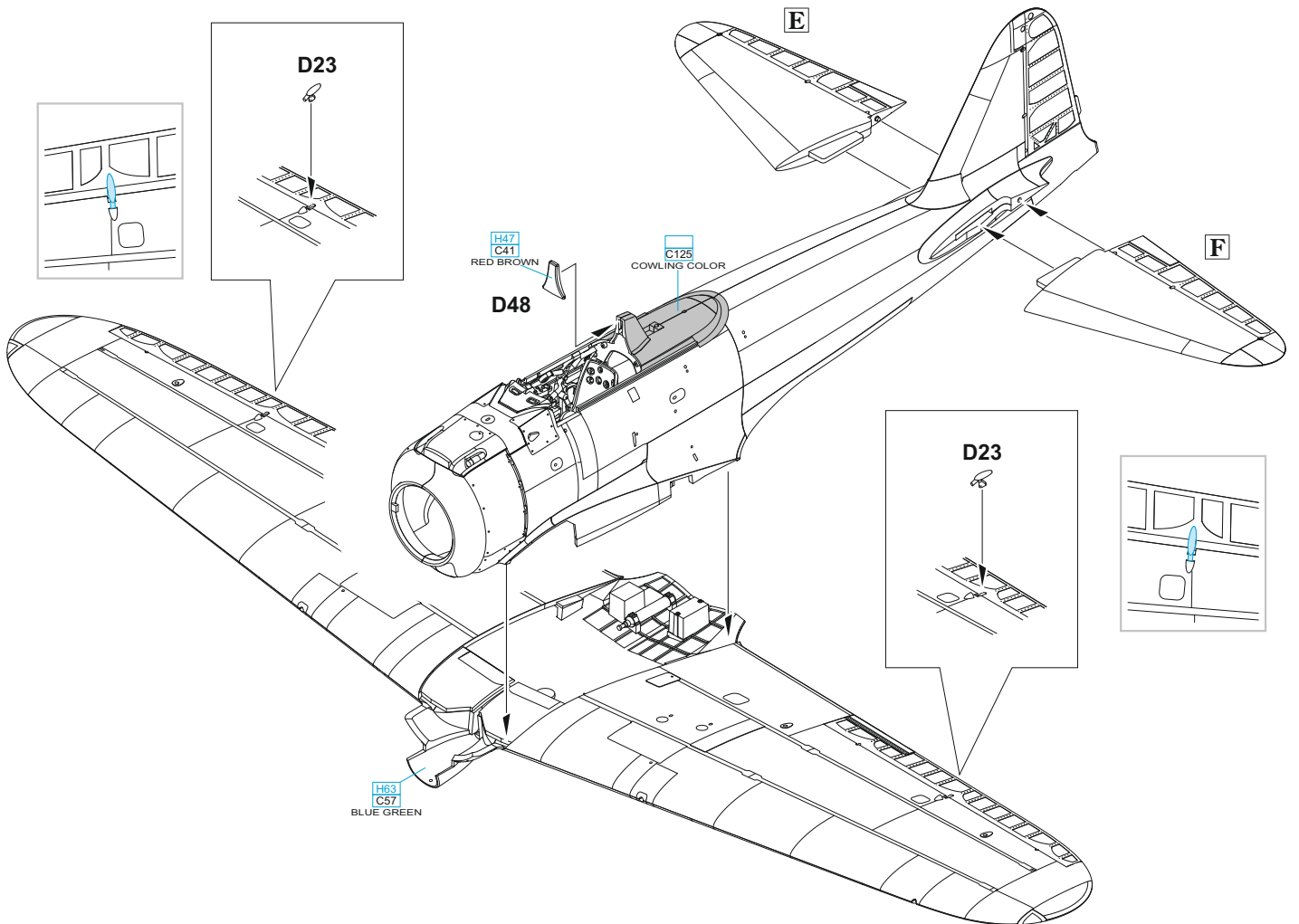
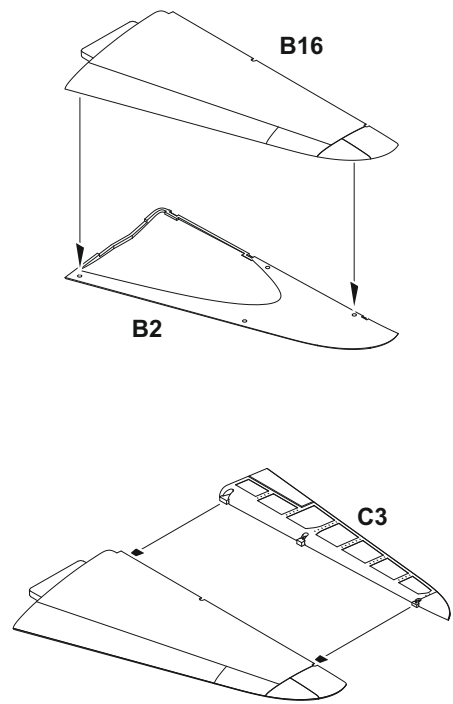
E**F**

G

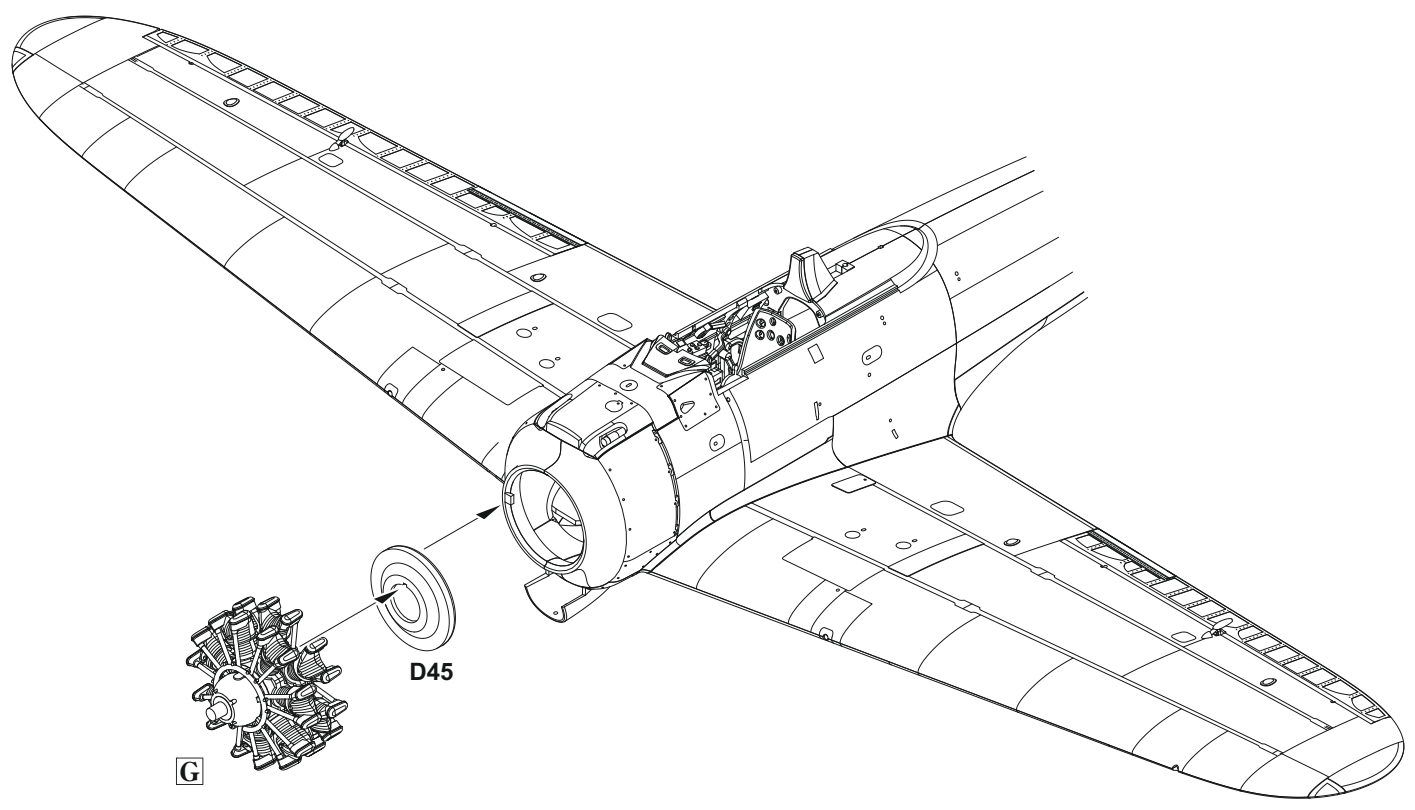
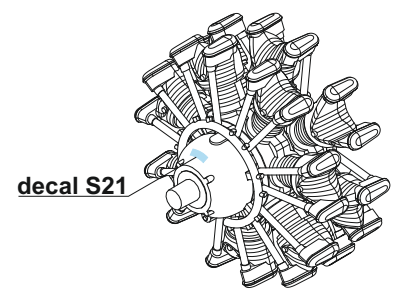
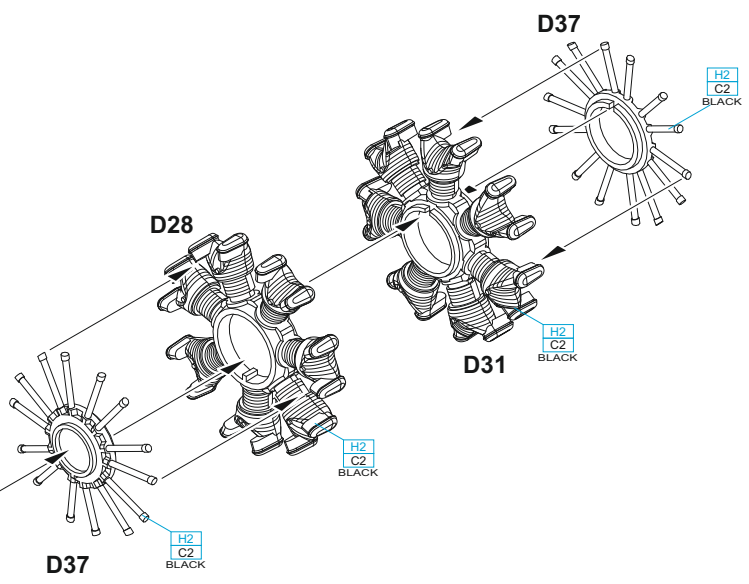
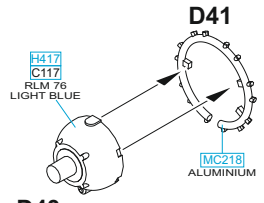

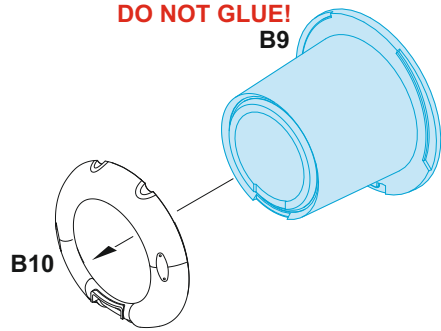
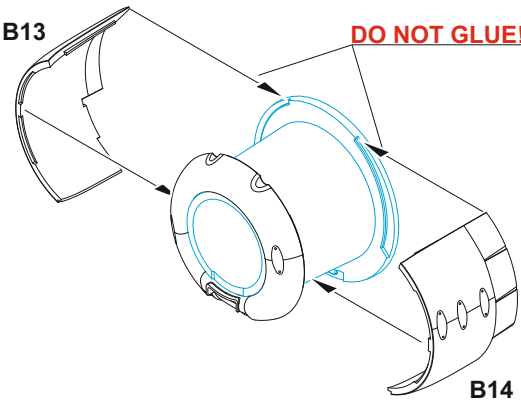
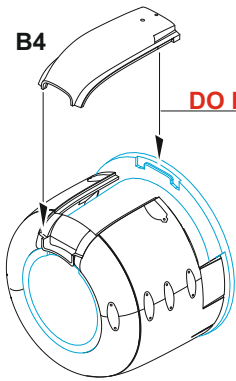
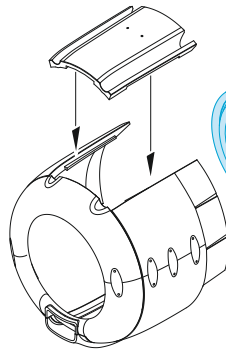
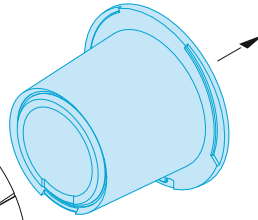
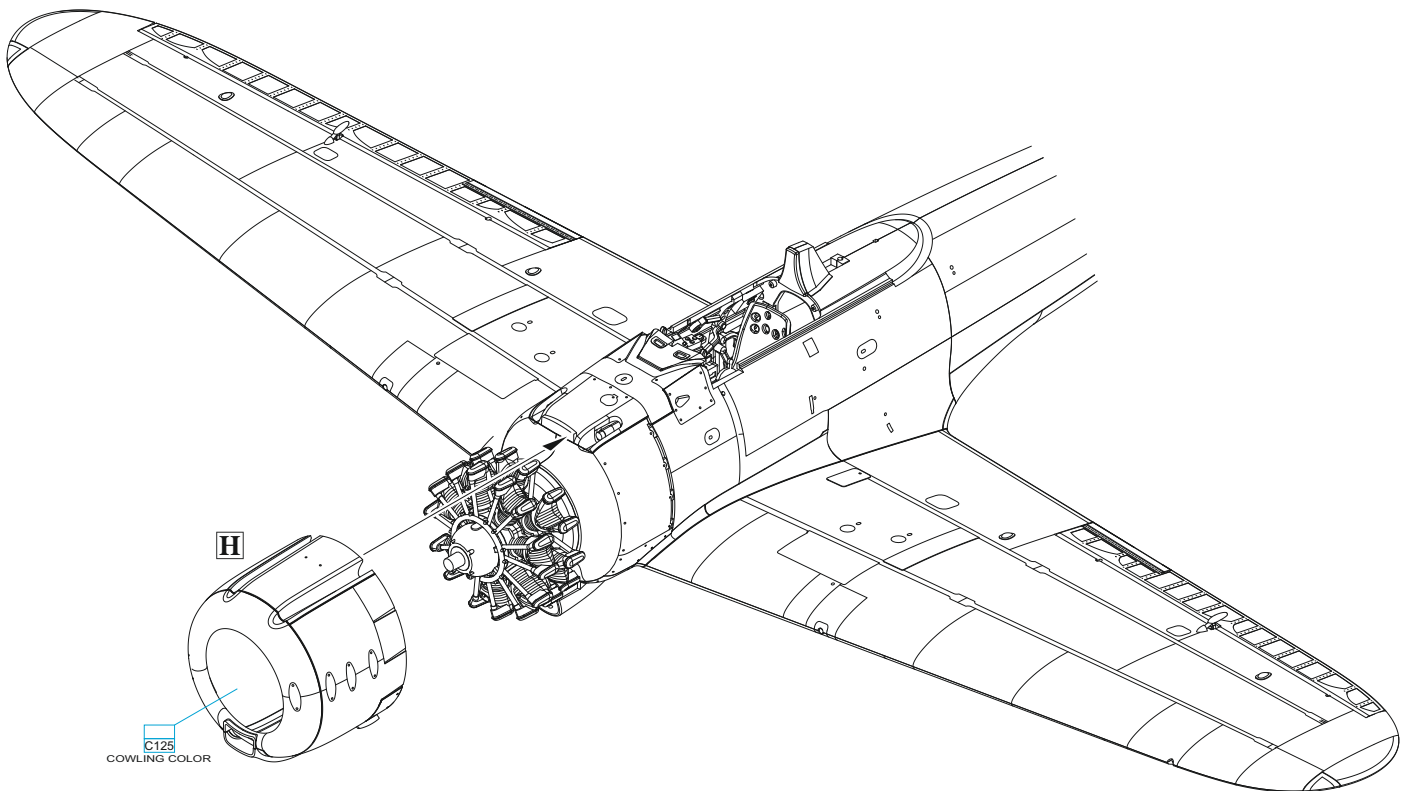
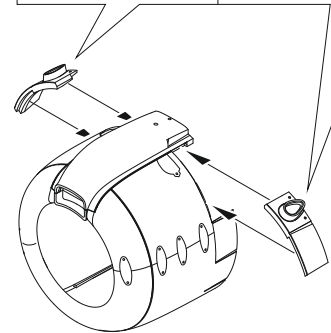
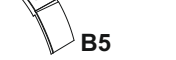
H**DO NOT GLUE!****B13****DO NOT GLUE!****B4****DO NOT GLUE!****step 2**
B15**step 1**
B9**B19**MC214
DARK IRON**B6****B20**MC214
DARK IRON**B5**

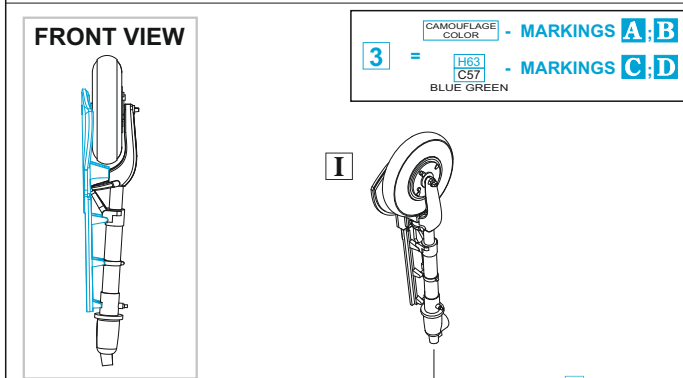
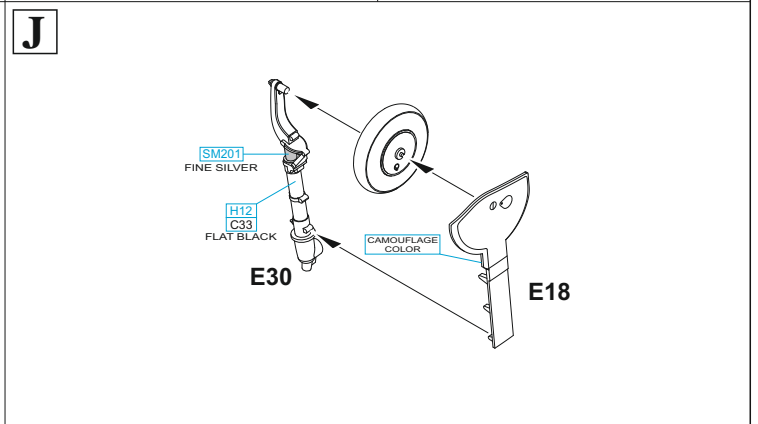
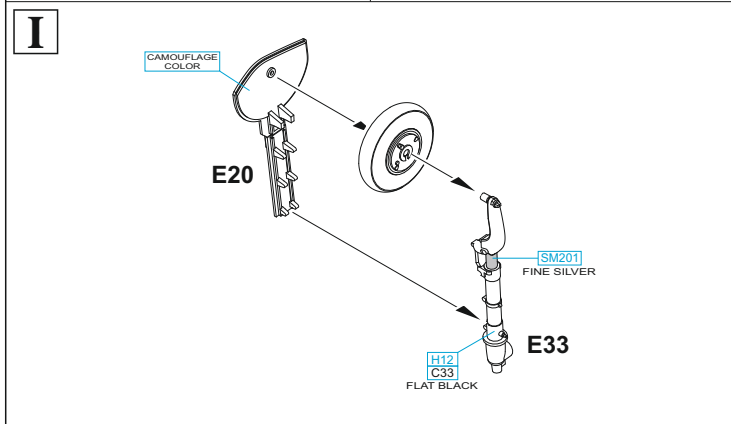
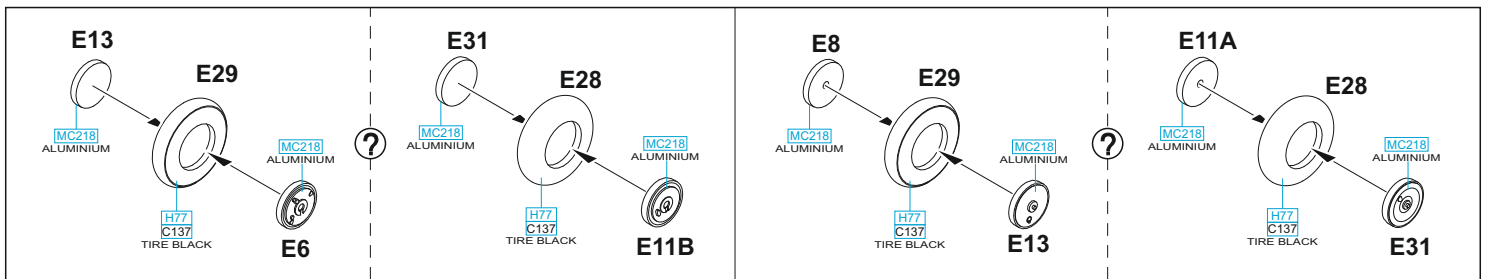

3 = CAMOUFLAGE COLOR - MARKINGS A;B
 H63 - MARKINGS C;D
 C57 - BLUE GREEN

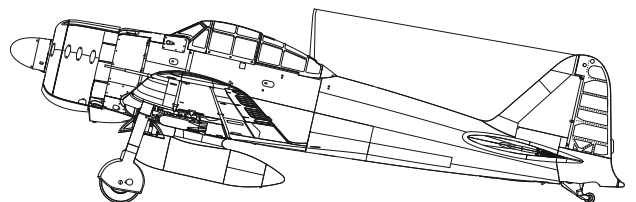
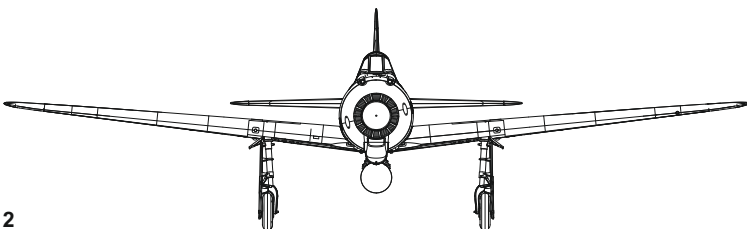
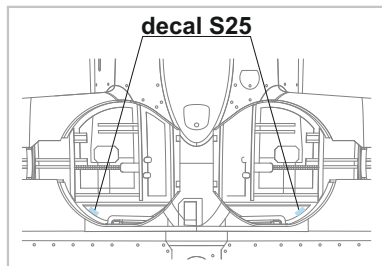
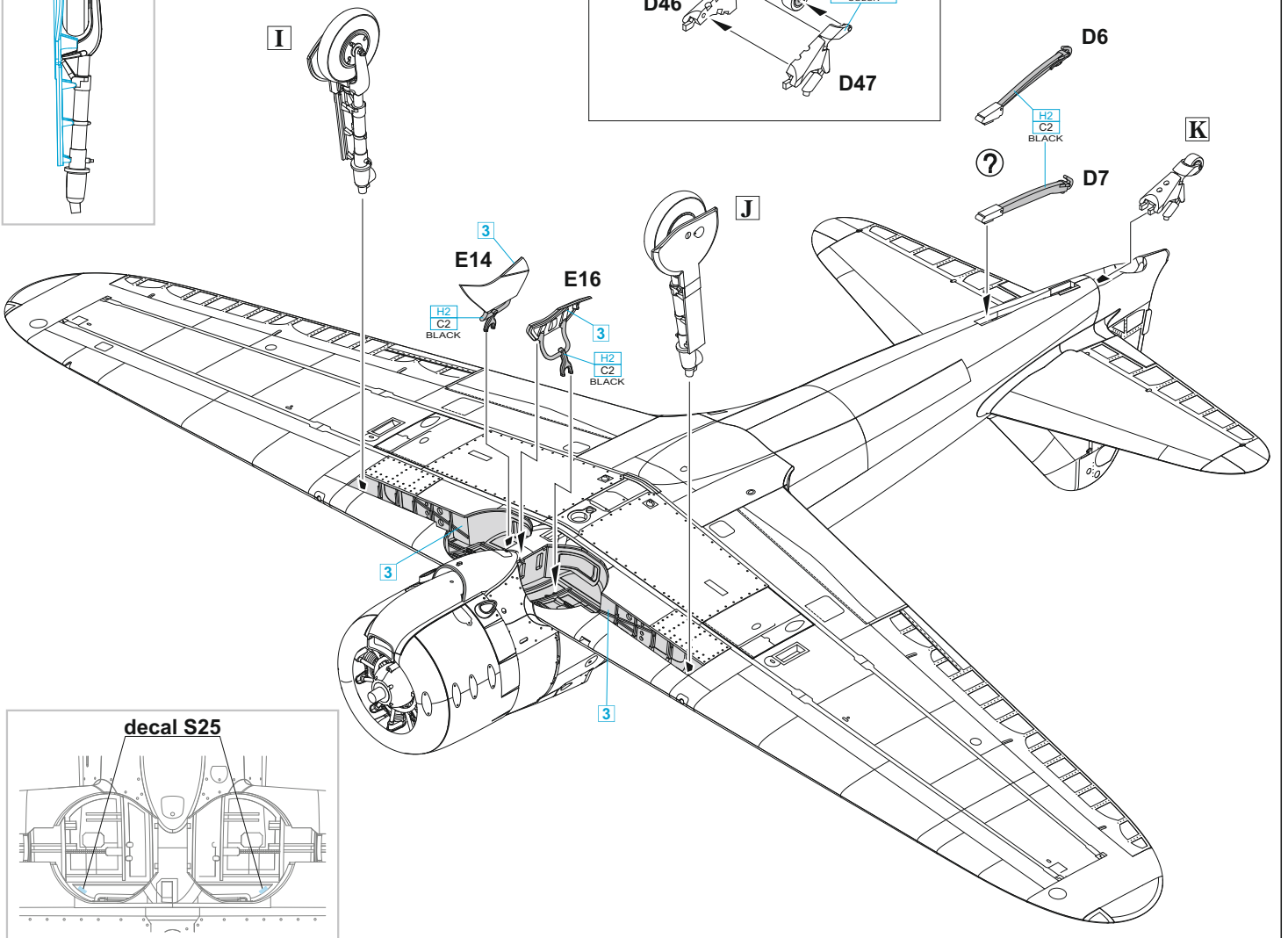
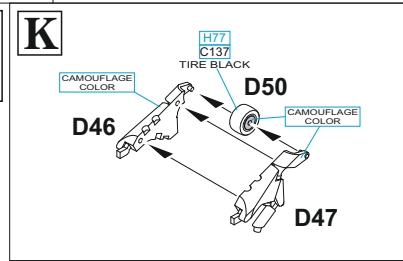

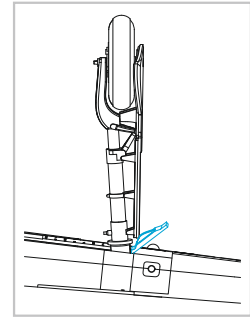
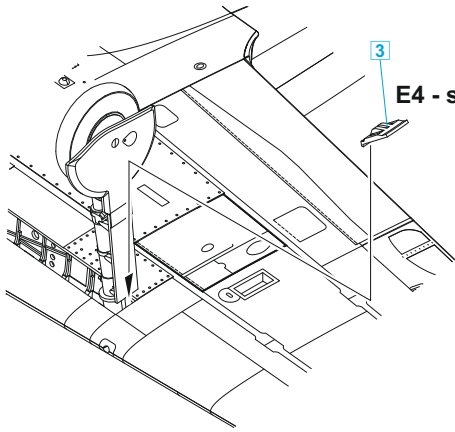

L 2 pcs. ? MARKING **C** ONLY

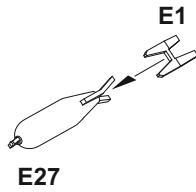

M ? MARKINGS **A**:**B**

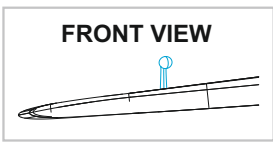
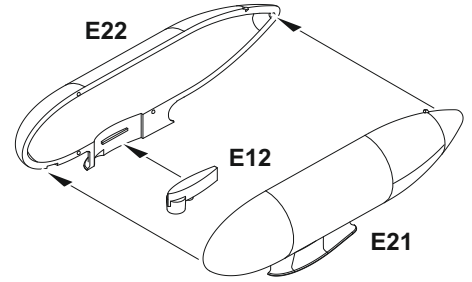

D56 - MARKING **A** ONLY

D56 ?

L



E32 ?

MARKING **C** ONLY

M

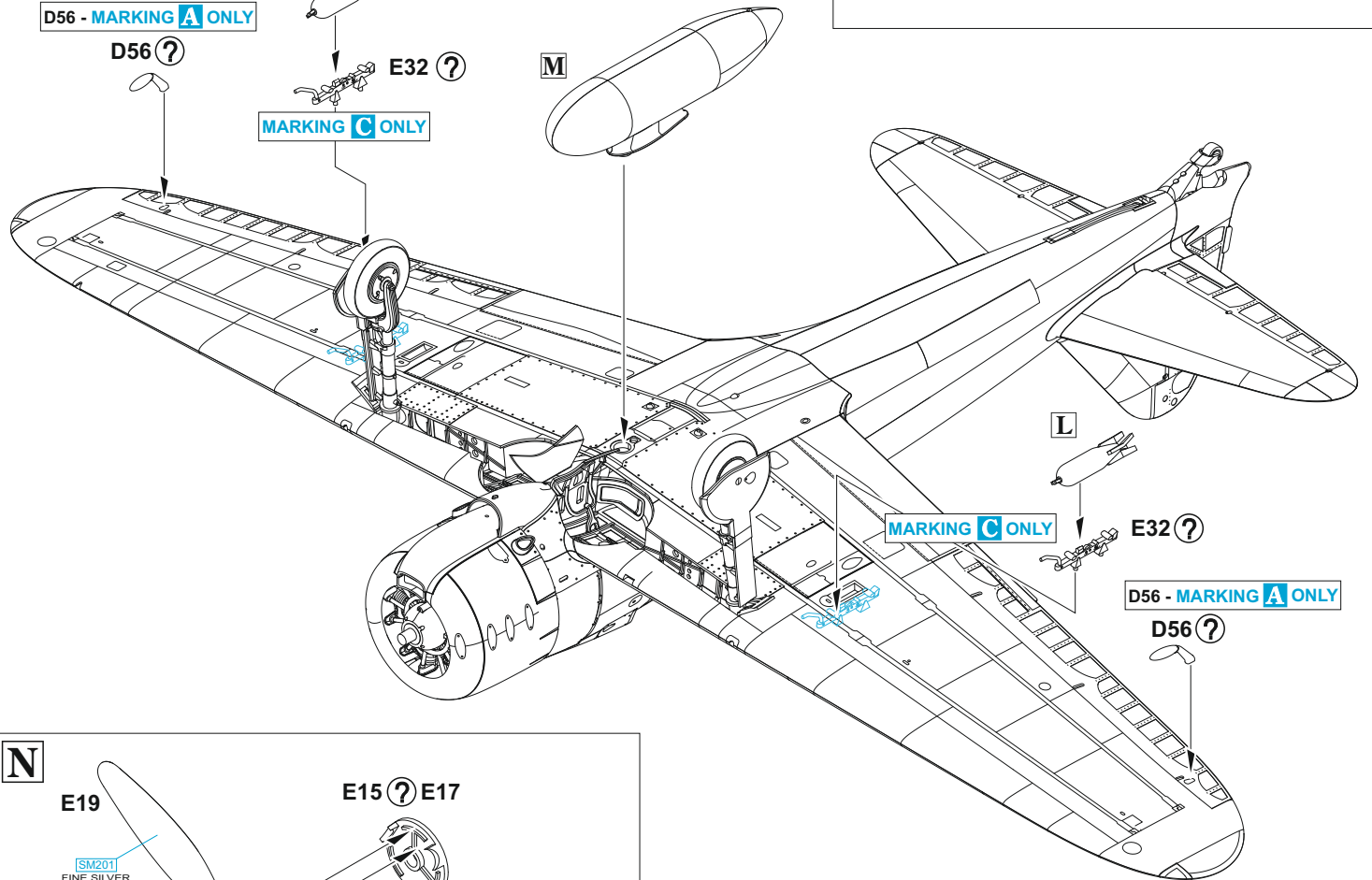

L

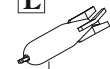

E32 ?

MARKING **C** ONLY

D56 - MARKING **A** ONLY

D56 ?

N

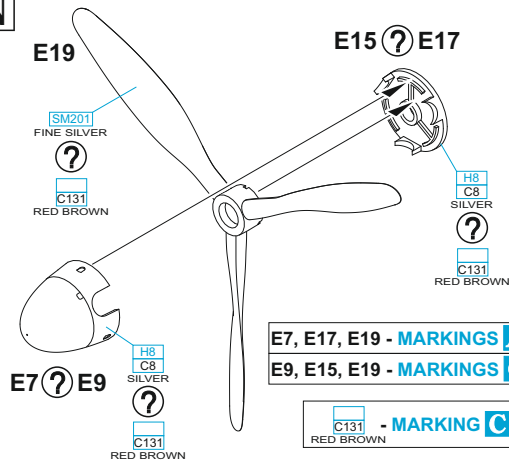

E19

E15 ? E17

SM201
FINE SILVER
?
C131
RED BROWN

H8
C8
SILVER
?
C131
RED BROWN

E7 ? E9

H8
C8
SILVER
?
C131
RED BROWN

E7, E17, E19 - MARKINGS **A**:**B**

E9, E15, E19 - MARKINGS **C**:**D**

C131 - MARKING **C** ONLY
RED BROWN

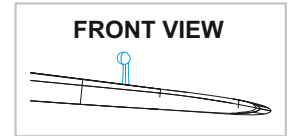

FRONT VIEW

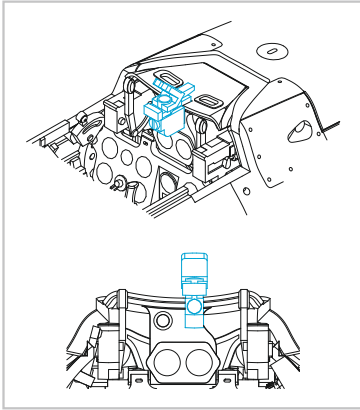
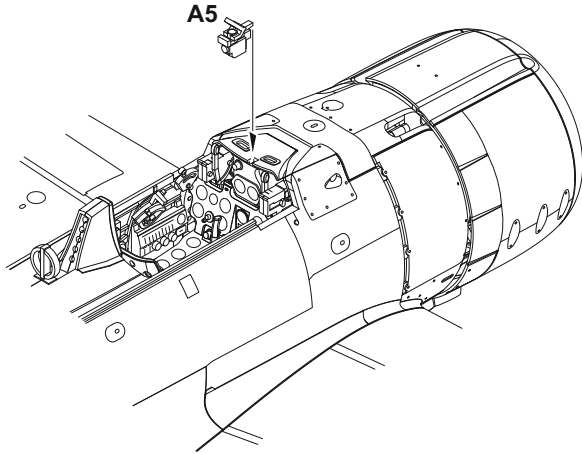
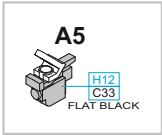

OPEN CANOPY

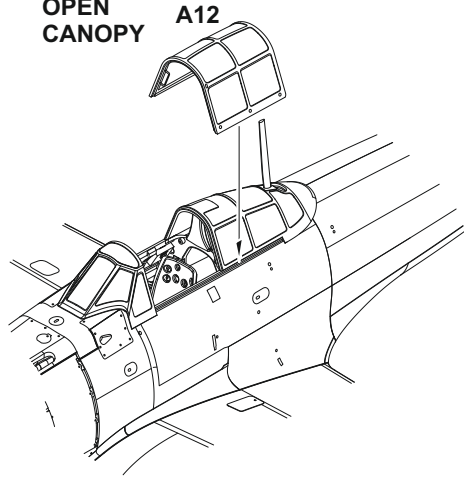

CLOSED CANOPY

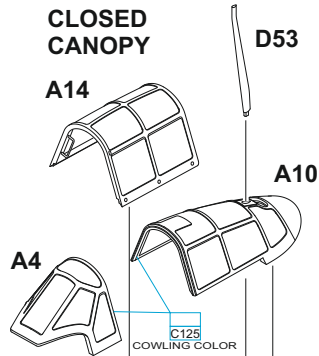

D62 - MARKING A ONLY

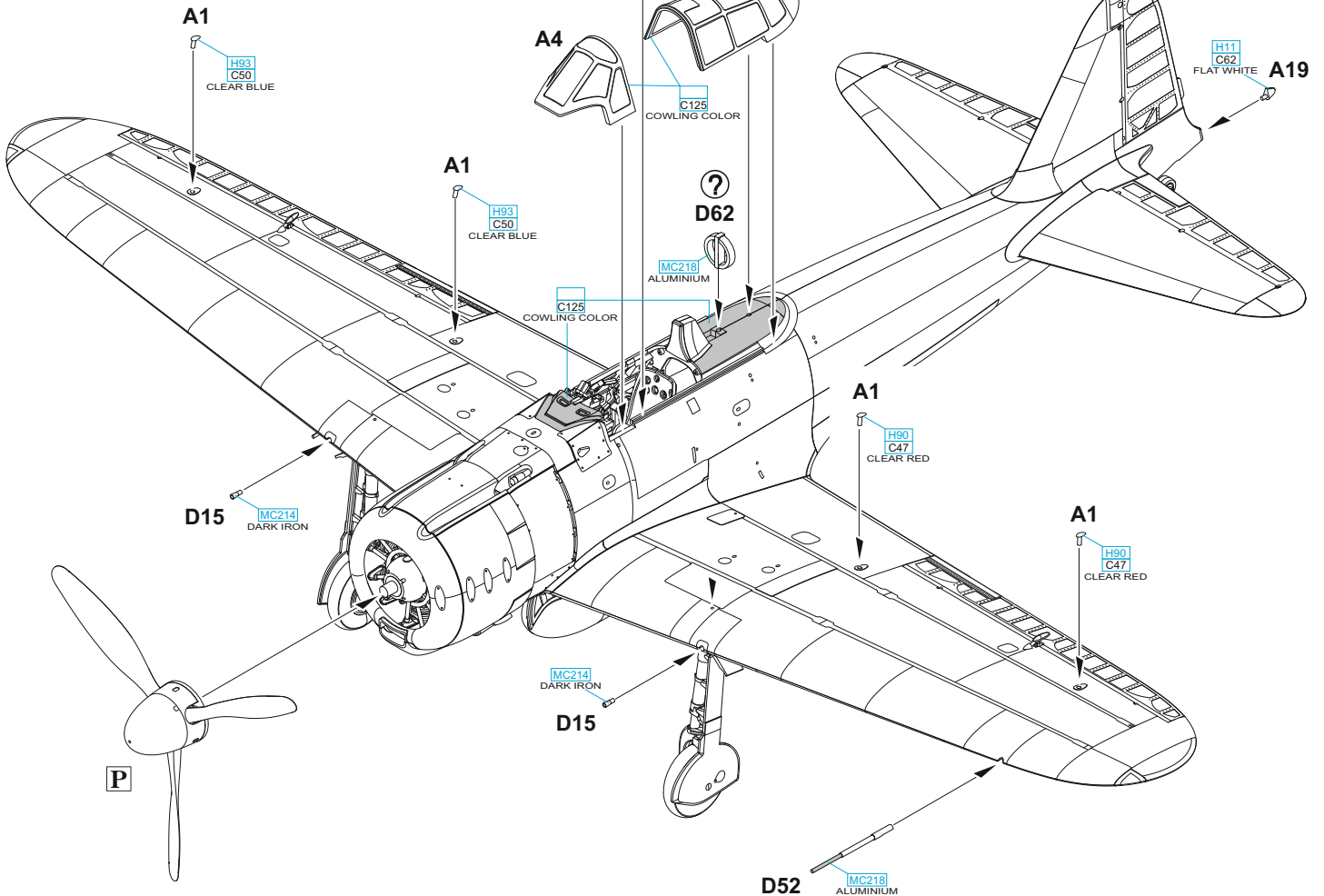

P

A c/n 5289, P01c Takashi Hirano, Akagi Fighter Squadron, December 1941

This Zero was manufactured by Mitsubishi, finished on August 9, 1941. It was one of the aircraft that were equipped with additional aileron mass balance. The design of the Roman numeral on this aircraft differed slightly on the right and left side of the tail. During the attack on Pearl Harbor it was flown by Takashi Hirano as a wingman of Lt. Cdr. Shigeru Itaya who led 43 Zero fighters, including nine from Akagi. Itaya's own Akagi formation shot down one sightseeing and three training aircraft. Then, at John Rodgers, Hickam and Ewa airfields, they destroyed about 25 aircraft and also attacked incoming B-17s. Hirano first shot down a Piper Cub near the Nuuanu Pali mountain pass in cooperation with Itaya's second wingman. Piper pilot Marcus F. Poston bailed out. Itaya and his wingmen damaged and set afire a B-17C of the 7th BG flown by the crew led by Capt. Swenson. The bomber broke in half on the ground and the fighters strafed its fleeing crew. Hirano mortally wounded the passenger, 1st Lt. (Dr.) William R. Schick, Flight Surgeon of the 38th Reconnaissance Squadron. However, the Hirano struck the ground, lost its auxiliary tank, damaged the propeller, and suffered an engine stall. Flying low between buildings, he then hit an obstacle, killing both himself and four American soldiers. A map was found in the wreckage of the Zero and with this information the Americans attempted to search for the Japanese task force.

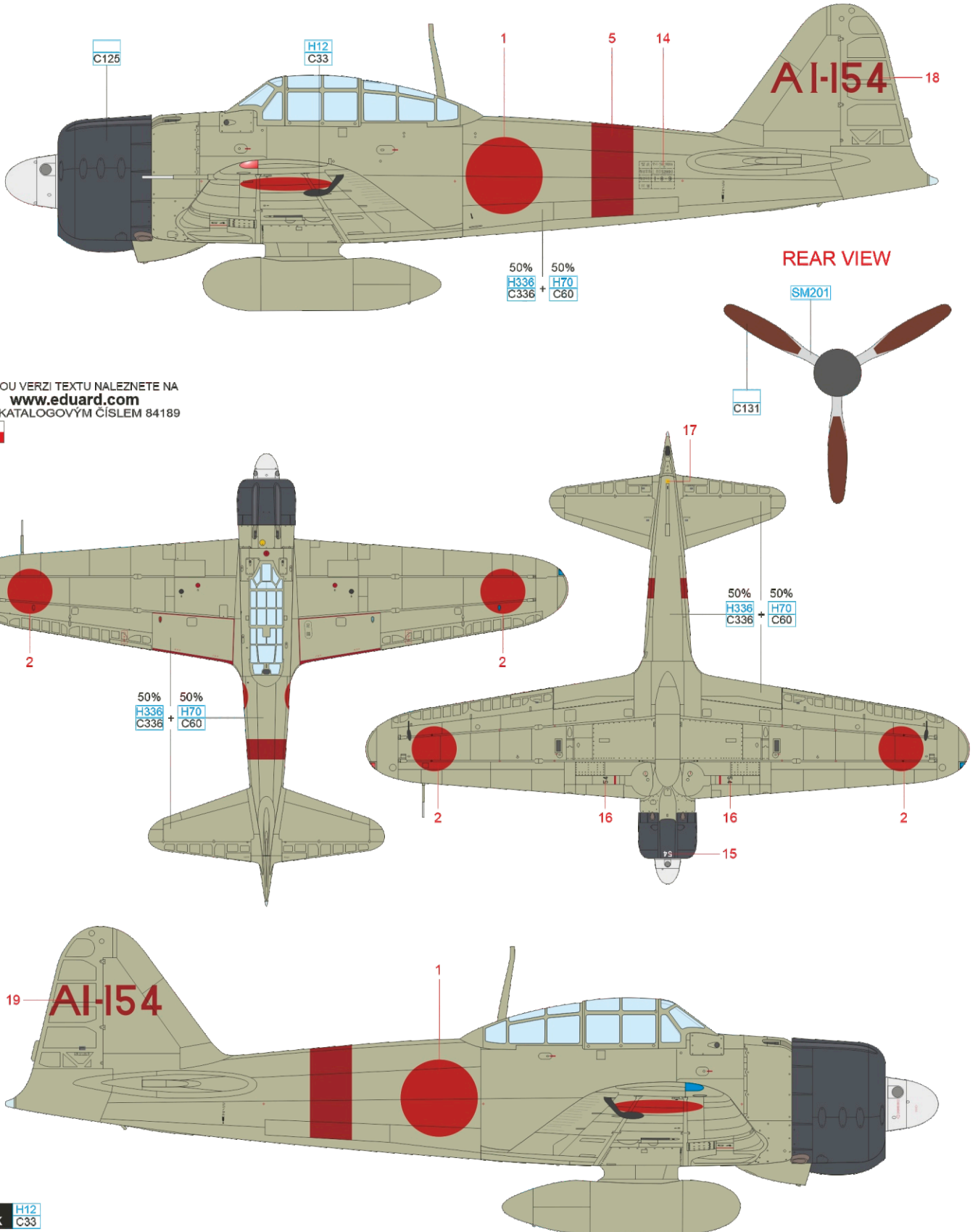

ČESKOU VERZI TEXTU NALEZNETE NA
www.eduard.com
 POD KATALOGOVÝM ČÍSLEM 84189



FLAT BLACK	H12 C33	HEMP	H336 C336	GRAY	H70 C60	COWLING COLOR	C125	RED BROWN	C131	SUPER FINE SILVER	SM201
------------	------------	------	--------------	------	------------	---------------	------	-----------	------	-------------------	-------

B c/n 5404, P03c Yoshirō Hashiguchi, 3. Kōkūtai, Kendari airfield, Dutch East Indies, March 1942

This aircraft left Mitsubishi factory on November 10, 1941 and was equipped with ailerons without additional mass balance. Its pilot was Yoshirō Hashiguchi (born 1918, Fukuoka). He completed his flight training in September 1938 and after further training with several units was assigned to the 12th Kōkūtai in China in June 1939. However, he was wounded in a Chinese raid on his unit's base and after recovering he became an instructor with the Suzuka Kōkūtai in January 1940. In November 1941 he was assigned to the 3rd Kōkūtai and successively fought in the Philippines, the Dutch East Indies or Guadalcanal and participated also in the raids on Australia. He returned to Japan in June 1943 and served as an instructor with the Ōita Kōkūtai. In December he was assigned to Kōkūtai 601 as a member of the carrier fighter squadron of the IJN Shōkaku and survived the Battle of the Philippine Sea. In July 1944 he was transferred to Hikōtai 164 as part of Kōkūtai 653 and took part in the Battle of Cape Engaño aboard the IJN Chiyoda on October 25. He made several operational sorties during the battle but remained missing after the sinking of the carrier. The total number of Hashiguchi's victories is not precisely known but is reported to be in excess of ten. At the time of his death, he held the rank of Chief Petty Officer and was posthumously promoted to Warrant Officer.

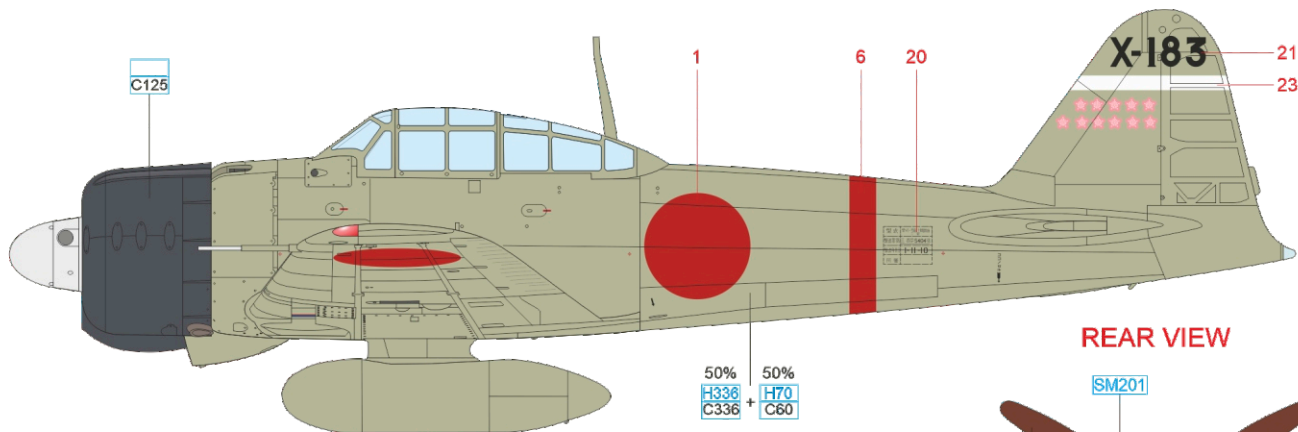

REAR VIEW

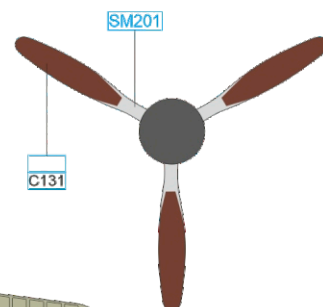

ČESKOU VERZI TEXTU NALEZNETE NA
www.eduard.com
 POD KATALOGOVÝM ČÍSLEM 84189

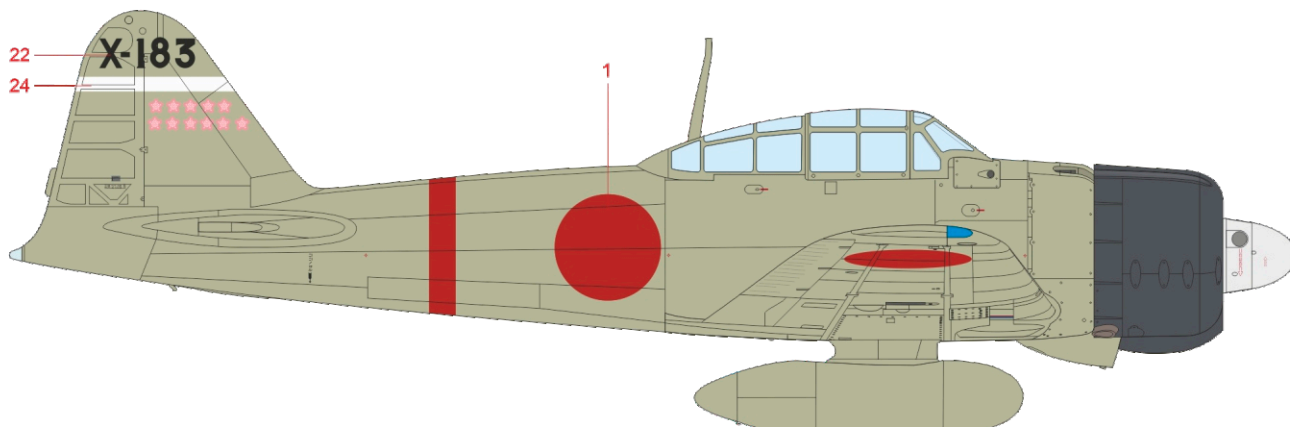
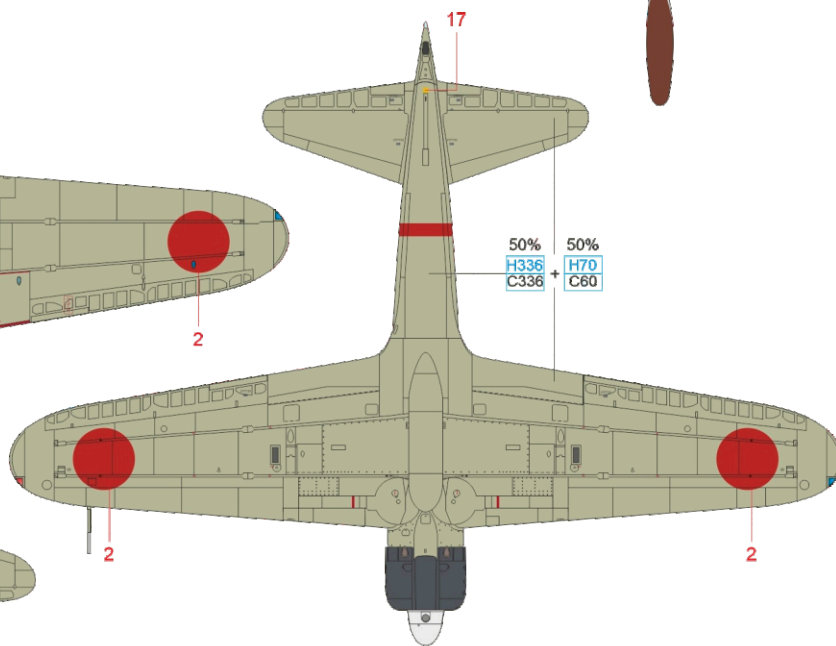
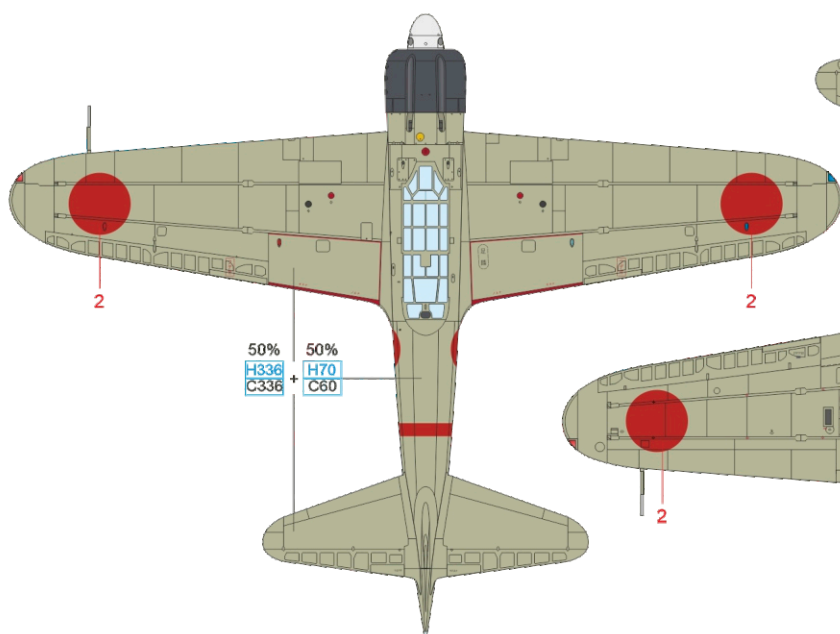

HEMP H336 C336 GRAY H70 C60 COWLING COLOR C125 RED BROWN C131 SUPER FINE SILVER SM201

eduard

This aircraft, probably built by Nakajima, bore dark green paint applied at unit level. Plane was seized by the Americans at the end of the war at Atsugi Base, where it was captured on both sides on a color footage. It bore considerable signs of wear and one aerial victory marked on the tail. The Zero was painted black on the underside of the wing, horizontal stabilizer and elevator. Kōkūtai 302 was established in 1944 as a unit dedicated to the defense of Yokosuka Base. Its 1st Hikōtai was armed with Raidens and Zeros, while its 2nd Hikōtai was armed with single- as well as twin-engine fighter and bomber aircraft that were modified for night interception. The unit specialized in fighting B-29 bombers both day and night. It was commanded by Capt. Yasuna Kozono, who had night fighter experience in the South Pacific when he commanded Kōkūtai 251 (formerly Tainan Kōkūtai) in 1943. He had its J1N Gekkō (Irving) reconnaissance aircraft fitted with fuselage-mounted guns that pointed obliquely upward for night pursuit purposes. He pushed the same solution, despite opposition from many pilots, for the Kōkūtai 302. A single fuselage-mounted gun was also fitted to some Zeros of Kōkūtai 302, as they were primarily intended for night pursuit. The YoD-1101 was not equipped with this additional armament. A Squadron (Buntai) of night-fighter Zeros claimed to shoot down seven B-29s, four fighters, one Catalina, and one Privateer.

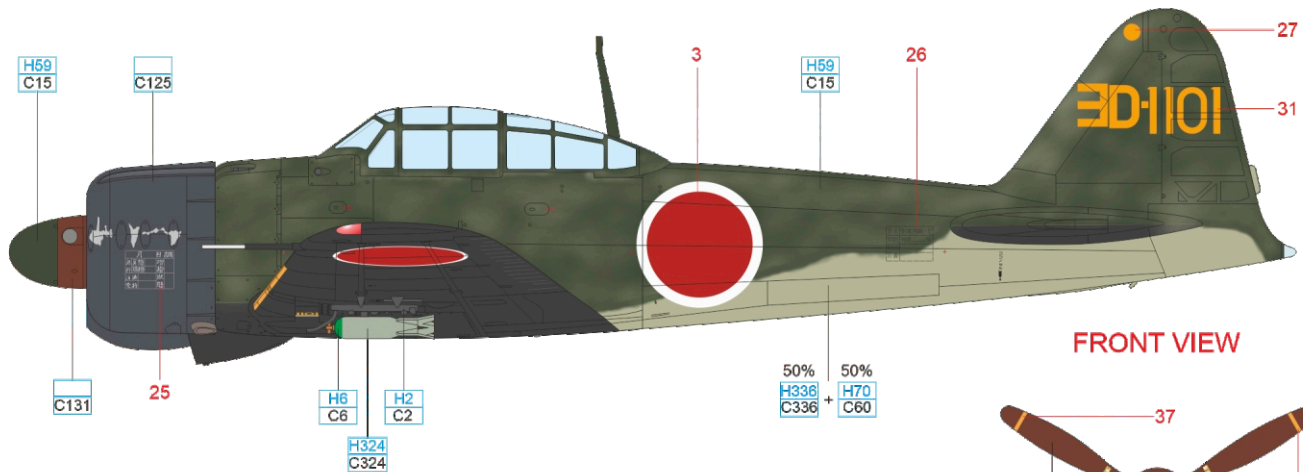

ČESKOU VERZI TEXTU NALEZNETE NA
www.eduard.com
 POD KATALOGOVÝM ČÍSLEM 84189

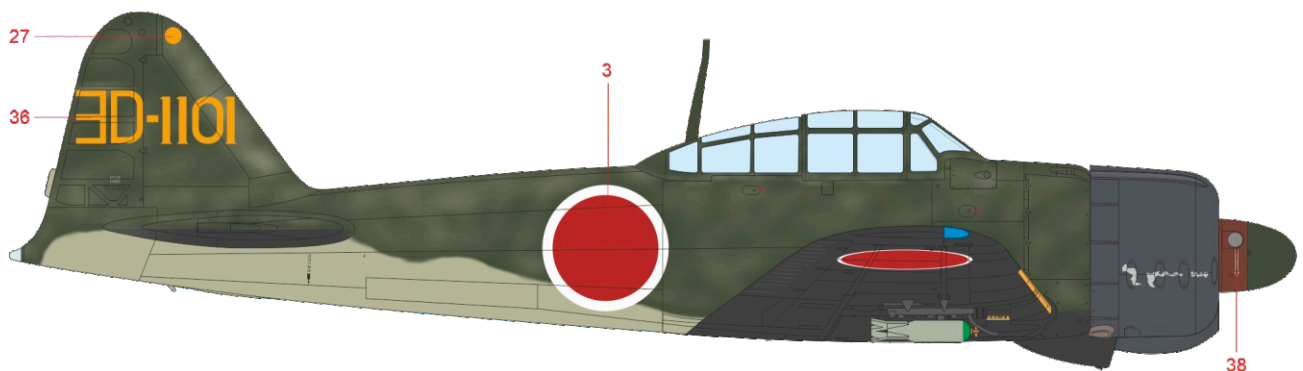
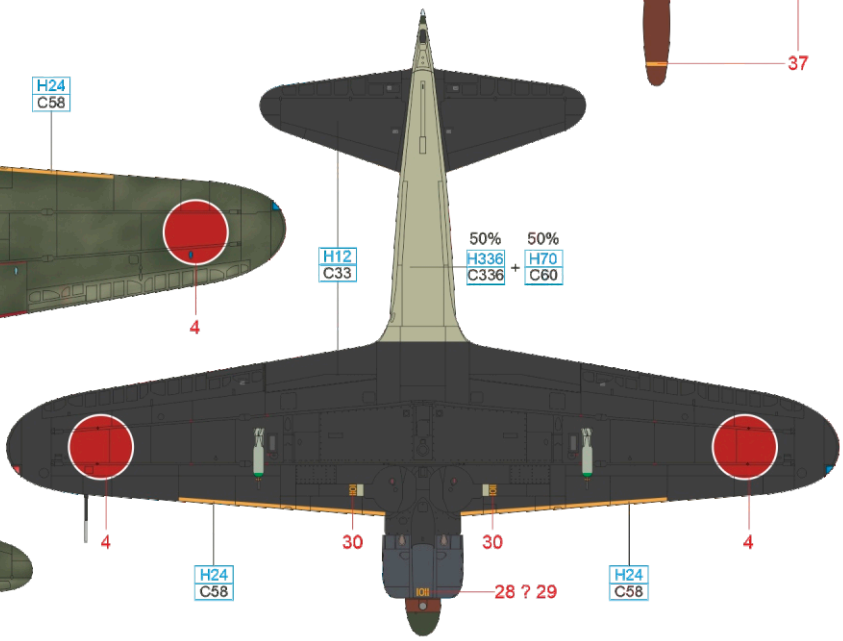
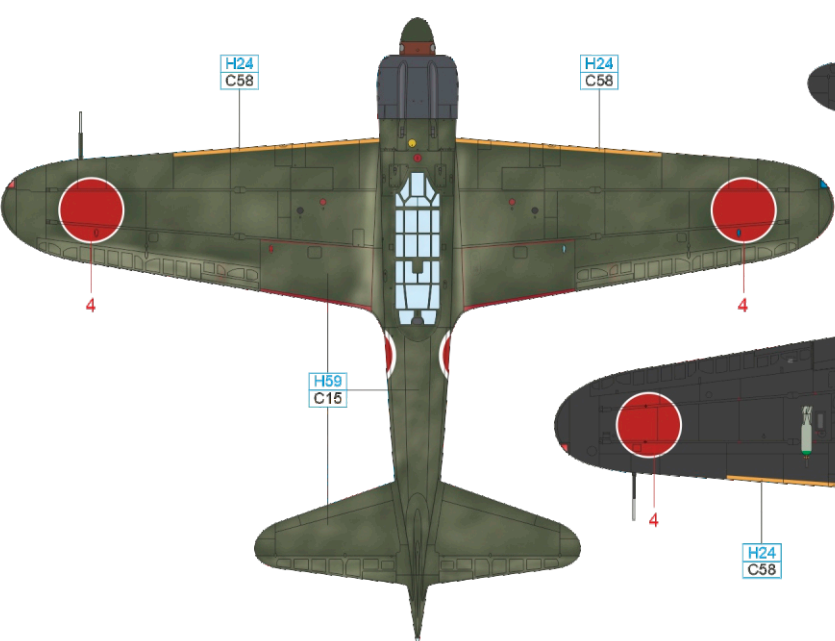

RED BROWN	C131	FLAT BLACK	H12 C33	BLACK	H2 C2	GREEN	H6 C6	LIGHT GRAY	H324 C324
HEMP	H336 C336	GRAY	H70 C60	COWLING COLOR	C125	ORANGE YELLOW	H24 C58	GREEN	H59 C15

D Kōkūtai 261, Kagoshima airbase, Japan, 1944

This Zero was manufactured by Nakajima with factory painted dark green paint on the upper surfaces. The white stripes and bands served as a quick identification feature but their exact purpose is unknown. Kōkūtai 261 was established in June 1943 at Kagoshima Air Base, Japan, and was given the battle name Tora (Tiger). It was also referred to as Tora Butai. The identifying feature of its aircraft was the numerical code 61, or Kanji character for tiger. Unit went through heavy combat with US Navy airmen, primarily in Central Pacific, but operated briefly also from Biak Island north of New Guinea. By May 1944, its aircraft strength was already reduced to half and in July the unit had to be disbanded due to high casualties. Some of the remaining members of the unit were killed in ground combat or aboard a submarine during the evacuation. The position of Hikōtaichō was held by Lieutenant Masanobu Ibusuki, who participated in the attack on Pearl Harbor and the Battle of Midway on the aircraft carrier Akagi and served on the aircraft carrier Shōkaku during the fighting in the South Pacific. It is possible that Ibusuki achieved from 25 to 30 aerial victories during the war. After the war, he became the first JSDAF unit commander with F-86 Sabre jets, reaching the rank of Lieutenant Colonel, but was killed in January 1957 in a collision with another F-86.

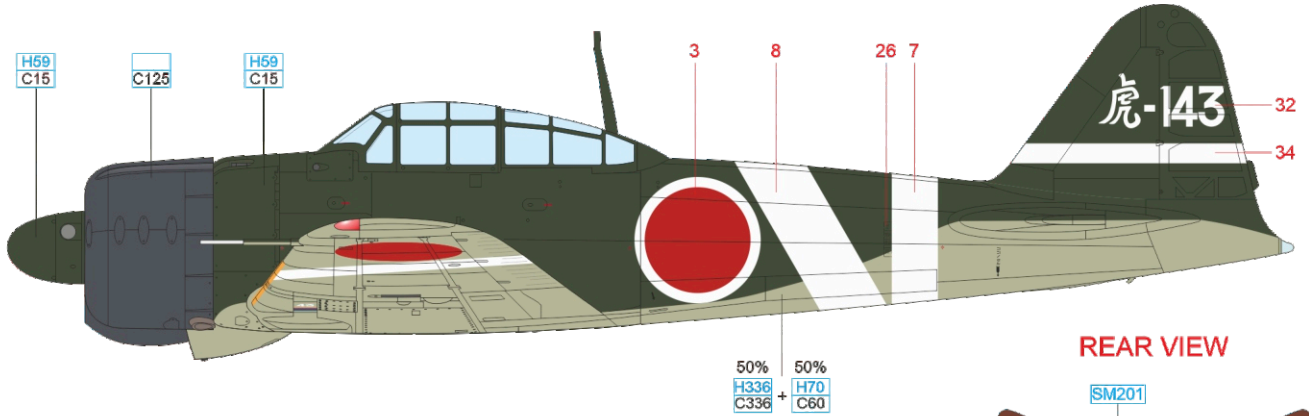

ČESKOU VERZI TEXTU NALEZNETE NA
www.eduard.com
 POD KATALOGOVÝM ČÍSLEM 84189

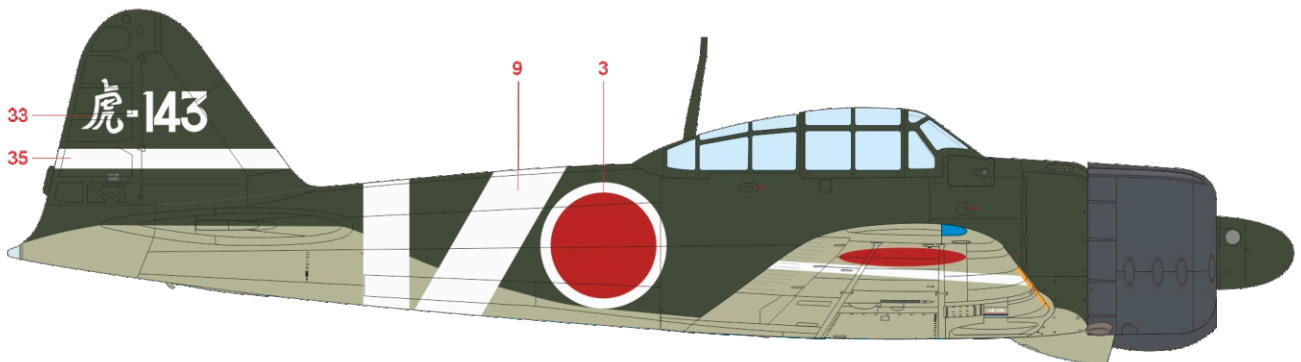
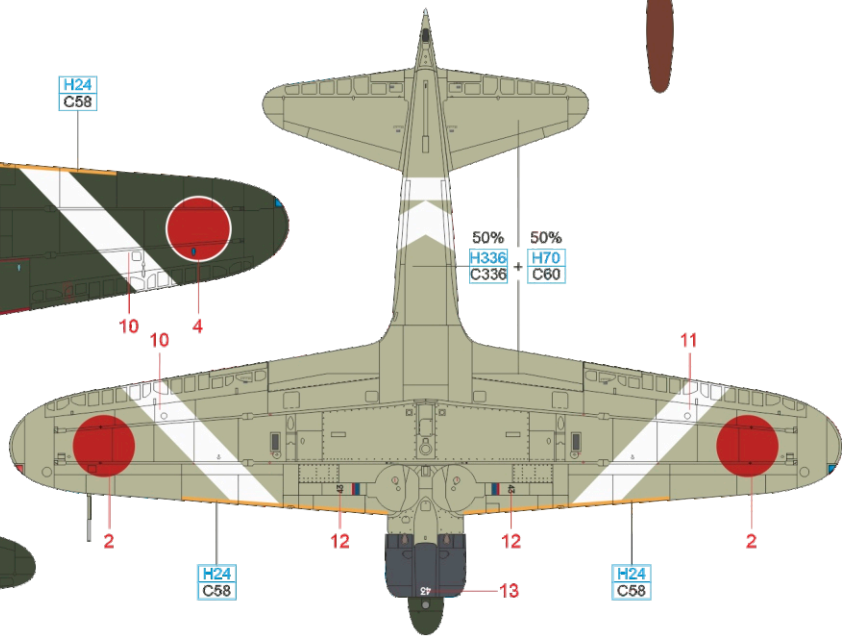
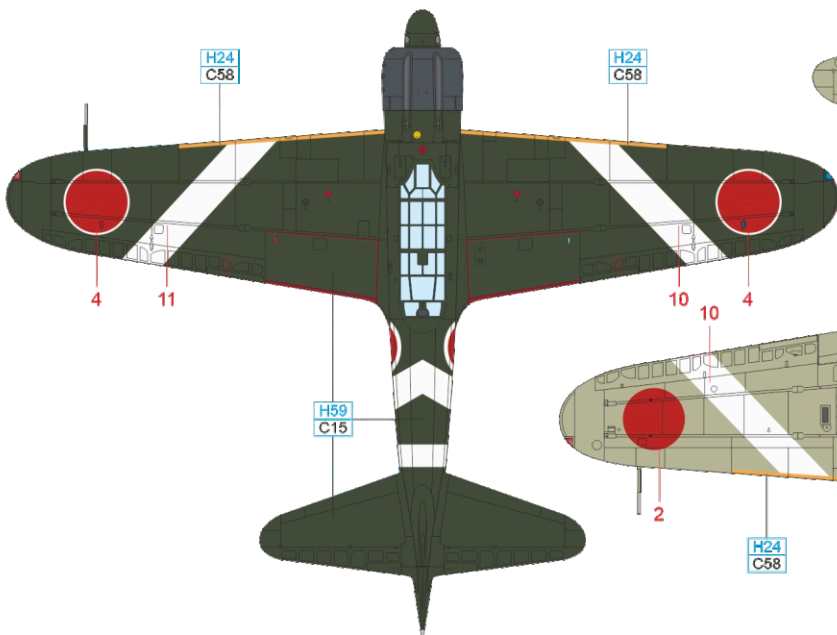

- RED BROWN C131
- SUPER FINE SILVER SM201
- HEMP H336 C336
- GRAY H70 C60
- COWLING COLOR C125
- ORANGE YELLOW H24 C58
- GREEN H59 C15

Eduard goodies for

A6M2 Zero Type 21 1/48

- 481076 A6M2 landing flaps (PE-Set)
- 481077 A6M2 Zero (PE-Set)
- FE1238 A6M2 seatbelts STEEL (PE-Set)
- 644128 A6M2 LööK (Brassin)
- 644134 A6M2 LööKplus (Brassin)
- 648692 A6M2 Zero Model 21 cockpit PRINT (Brassin)
- 648693 A6M2 wheels (Brassin)
- 648694 A6M2 engine PRINT (Brassin)
- 648695 A6M2 undercarriage legs BRONZE (Brassin)
- 648698 A6M2 seat PRINT (Brassin)
- 648722 A6M2 exhausts PRINT (Brassin)
- 648723 A6M2 cannon barrels & cockpit guns PRINT (Brassin)
- 648724 A6M2 landing flaps PRINT (Brassin)
- 648731 A6M2 Zero Model 21 folding wingtips PRINT (Brassin)
- 648763 A6M2 engine complete PRINT (Brassin)
- 648771 A6M2 gun bays PRINT (Brassin)
- 648772 A6M2 tailwheel PRINT (Brassin)
- 648808 A6M2 wheels w/smooth tire (Brassin)
- 3DL48050 A6M2 SPACE (3D Decal Set)
- D48098 A6M2 stencils (Decal Set)
- D48100 A6M2 national insignia (Decal Set)
- EX821 A6M2 TFace (Mask)

Cat. No. 644128

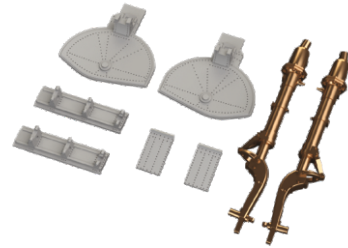
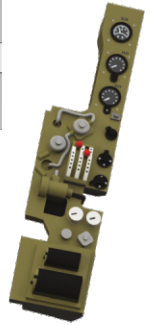
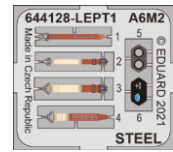

Cat. No. 648695

Cat. No. 648731

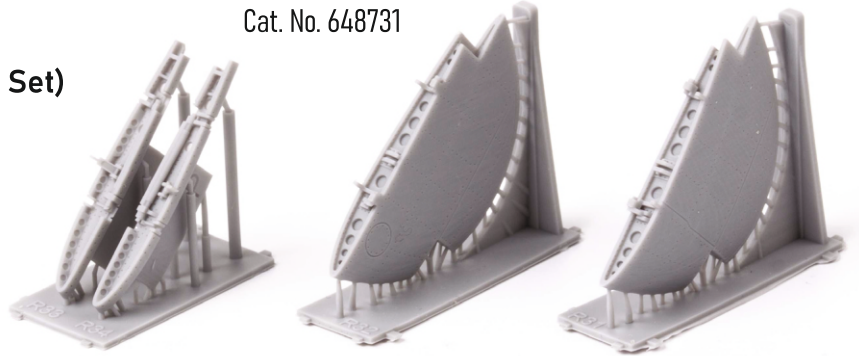

Cat. No. 648772



Cat. No. 648771

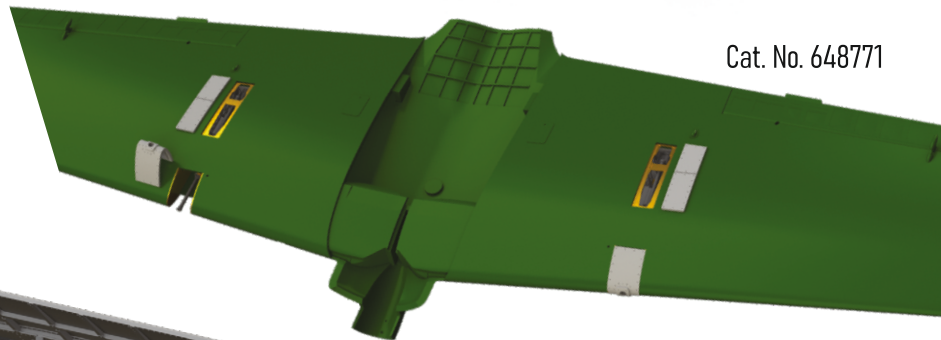

Cat. No. 648724

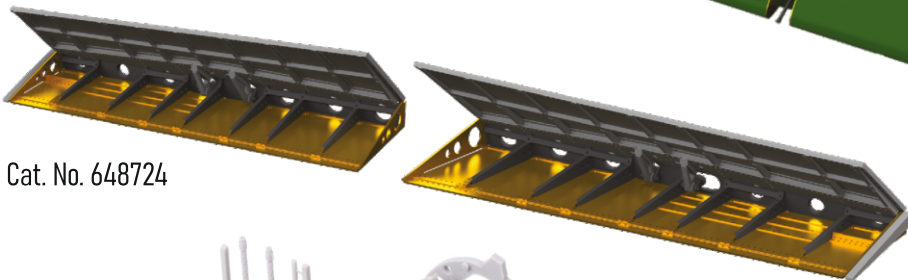

Cat. No. 648692

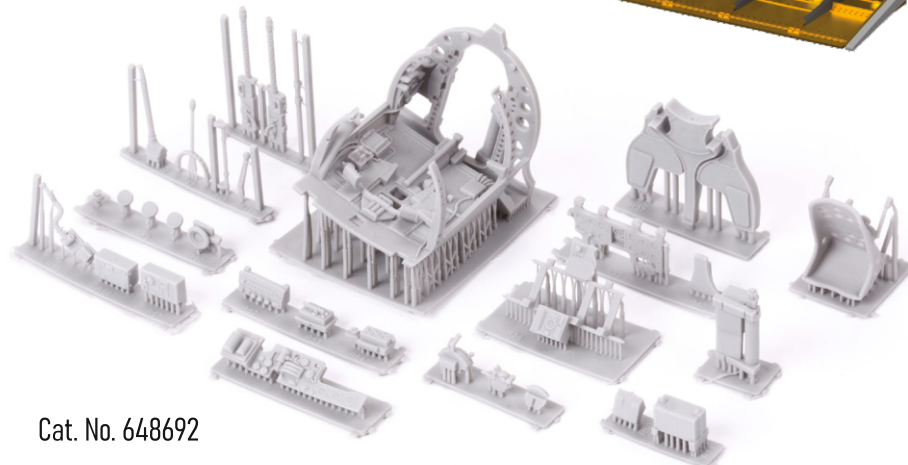

Cat. No. 648694

