

SCALE  
1/48

F-14A

ITEM #  
D48105

BuNo. 161856, VF-211 Fighting Checkmates, USS Nimitz, 1997

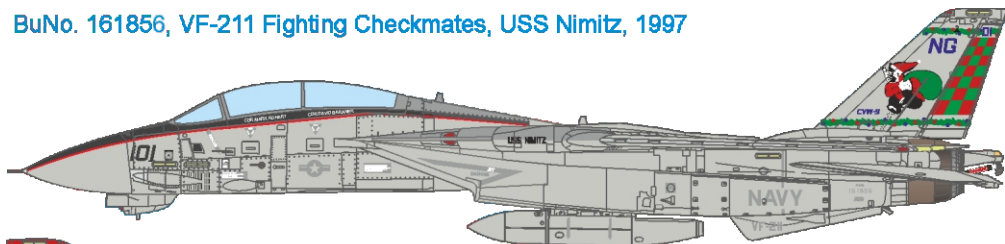

BuNo. 161621, VF-111 Sundowners, USS Carl Vinson, 1999

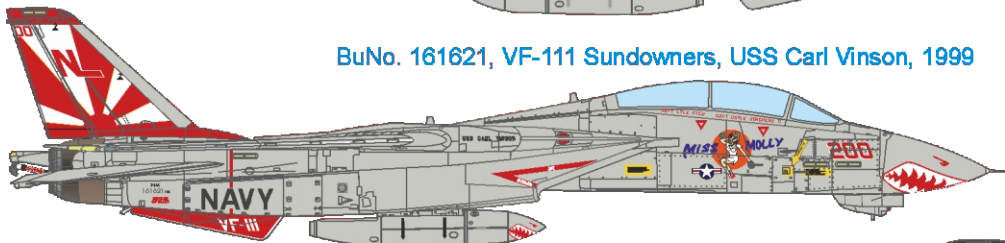

BuNo. 160390, VF-84 Jolly Rogers, USS Nimitz, 1993

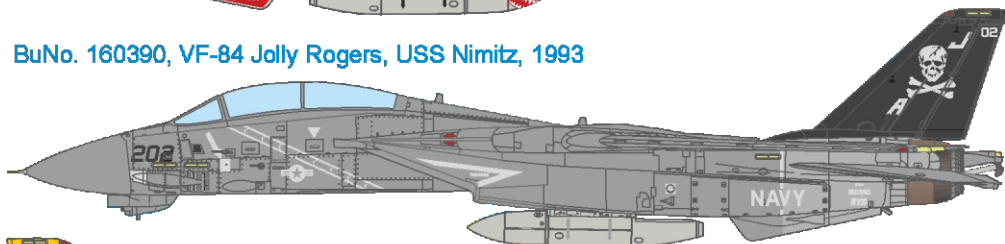

BuNo. 161601, VF-21 Freelancers, USS Constellation, 1987

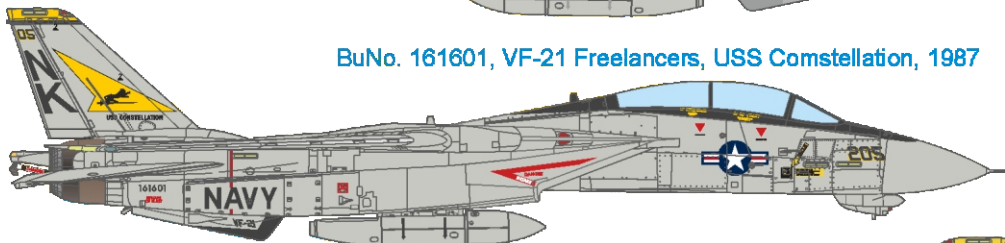

BuNo. 162589, VF-124 Gunfighters, NAS Miramar, 1987

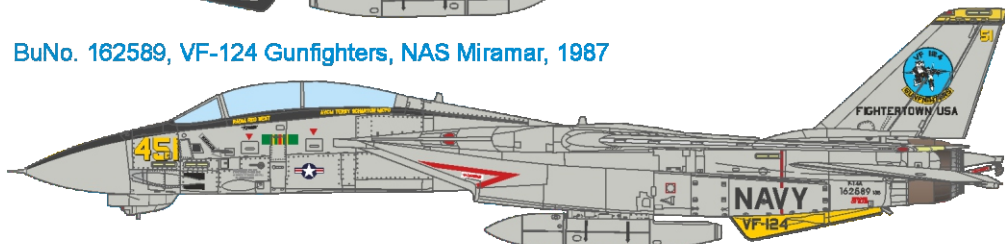

DESIGNED EXCLUSIVELY FOR F-14A BY TAMIYA



Eduard - Model Accessories, 435 21 Obrnice 170,  
Czech Republic

WWW.EDUARD.COM

D48105 F-14A 1/48



8 4591437 570393

# Recommended accessories for F-14A 1/48:

- 48910 F-14A engines (PE-Set)
- 481075 F-14A late exterior (PE-Set)
- 49806 F-14A seatbelts STEEL (PE-Set)
- 491239 F-14A late interior (PE-Set)
- FE1239 F-14A late interior (PE-Set)
- BIG49318 F-14A late (PE-Set)
- 644040 F-14A LööK (Brassin)
- 644078 F-14A w/ early wheels LööKplus (Brassin)
- 644084 F-14A w/ late wheels LööKplus (Brassin)
- 644151 F-14A late Löök (Brassin)
- 648293 F-14A ejection seat (Brassin)
- 648304 F-14A wheels early (Brassin)
- 648311 F-14A exhaust nozzles (Brassin)
- 648739 F-14A late cockpit (Brassin)
- SIN64881 F-14A late AtA/AtG (Brassin)
- 3DL48015 F-14A SPACE (3D Decal Set)
- 3DL48057 F-14A late SPACE (3D Decal Set)
- EX730 F-14A TFace (Mask)

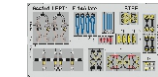
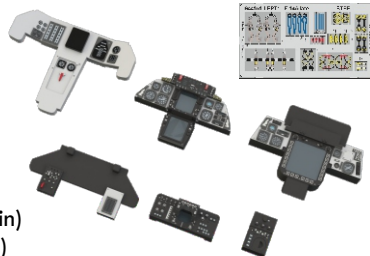

Cat. No. 648304

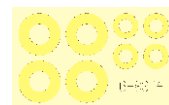

Cat. No. 648311

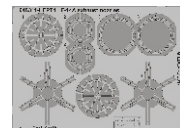
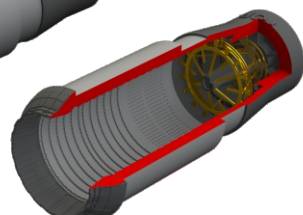
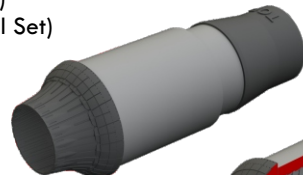

Cat. No. 648293

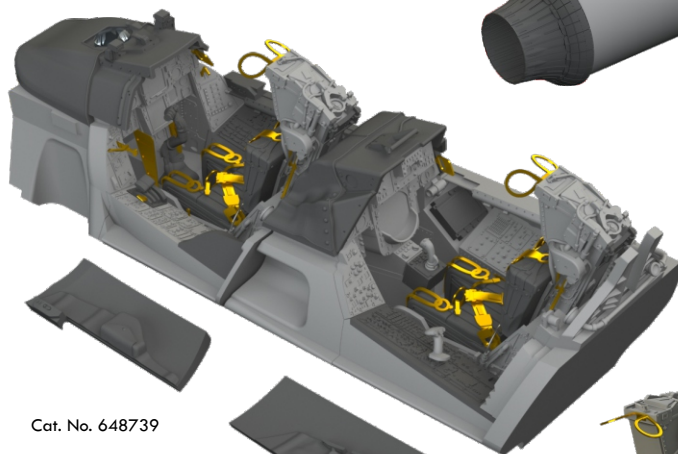

Cat. No. 648739

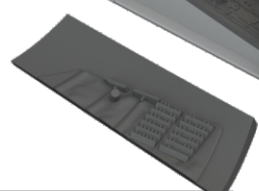

Cat. No. 3DL48057

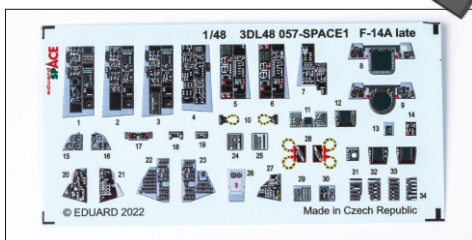

© EDUARD 2022

Made in Czech Republic

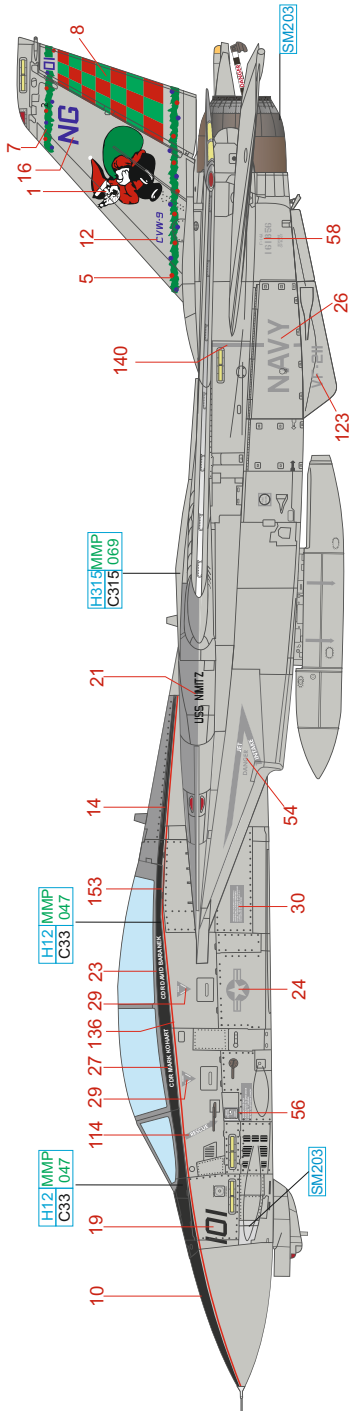

F-14A-130-GR, Bu.No. 161856, VF-211 Fighting Checkmates, USS Nimitz, during Operation Southern Watch in Iraq, 1997. When the squadron was deployed during Christmas 1995, the aircraft has the Grinch on the tails of the CO's jet, NG101. The Grinch is familiar to Americans from the popular book and TV show "How the Grinch Stole Christmas". After many suggestions, the squadron chose the design submitted by LCDR "Mac" Singletary, who was also the squadron maintenance officer. Mac's design showed the character from the squadron logo, who called "Brutus", dressed as Santa Claus, complete with the bag of goodies. Some of pilots called the design "Santa Brutus." The aircraft assigned to the commanding officer of VF-211 Fighting Checkmates David Baranek. The aircraft was handled by 24 year old Aviation Structural Mechanic Airman (AMSN) Michael Kreisher, who had been with VF-211 a couple of years, because his supervisor had noticed his talent and figured he was the best for this job. The paint is December'97 version of the "Santa Brutus" with white pompon on his cap. The aircraft was converted to F-14B version in 1998.

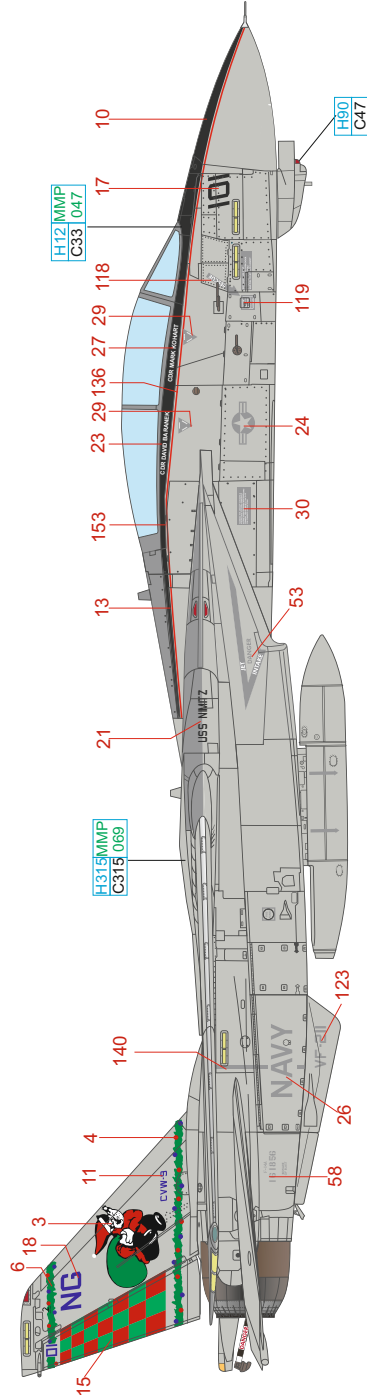









INNER SIDE OF THE TAILS





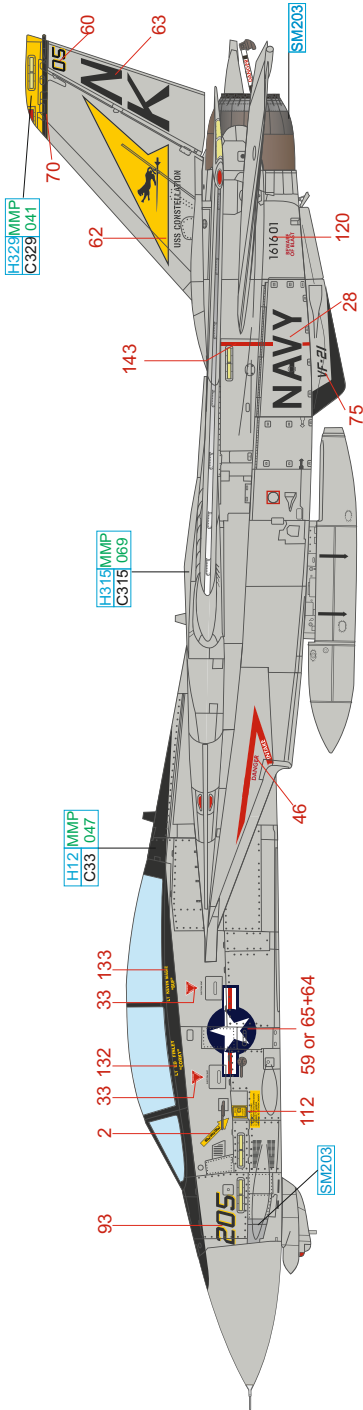

F-14A-125-GR, Bu.No. 161601, VF-21 Freelancers , USS Comstellation, 1987. VF-21 and VF-154 were the last US-based squadrons to fly F-4s (although there were two forward deployed squadrons continued to operate the F-4). In 1987, VF-21 launched AIM-7 Sparrow missiles against an Iranian F-4 that had engaged a P-3 Orion in the Persian Gulf. The aircraft was converted into the F-14A+, later redesignated as F-14B. Crashed 13.09.1993 when it was on service in VF-103. Due to aircraft malfunction, the crew was forced to eject, pilot and RIO were rescued by fishing boats 40 miles northeast of Cape Hatteras (NC). Take note that the aircraft had bullet type of TCS pod.

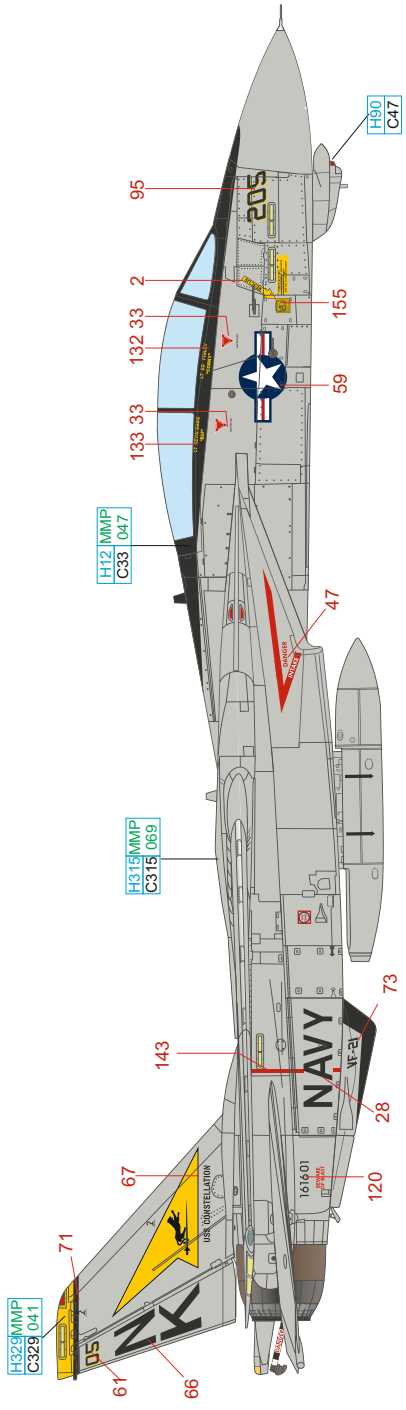





INNER SIDE OF THE TAILS

