

Siebel Si 204E 'German Night Bomber & Trainer'

EN

In 1934 in the German city of Halle, Hanns Klemm, an aircraft designer and manufacturer, set up a branch of his aircraft factory. The new plant was to produce multi-engined, all-metal aircraft, in contrast to the original factory where wood was still being used for building the aeroplanes. In 1937, the Halle plant was taken over by the famous German aviator Friedrich Siebel who also gave it his name. The plant mainly focused on licence-built designs, but had a couple of their own aircraft designs too. The first type to be produced by this new plant was the Fh 104 Hallore, a design in fact originating in the Klemm works.

In 1938, Germany's flag carrier Deutsche Luft Hansa in cooperation with the RLM announced tender for a fast, twin-engined transport aircraft. Before the winning design could be found, the war had broken out which meant the new type would be used just (or mainly) by the German military. The prototype Si 204A first flew on 23 May 1941, being of an all-metal construction and powered by a pair of Argus As 411 engines and differed from all later versions by having a stepped pilots' canopy. Its production was commenced at the Halle plant at first but as their workers were busy with producing Ju 88 bombers, the production was later transferred to the French Société Nationale de Constructions Aéronautiques du Nord (SNCAN). The third prototype machine was finished as the new Si 204D version which had completely glazed pilots' office similar to that of the He 111H/P and Ju 88A bomber aeroplanes and in this new configuration, the type perfectly suited to the trainer role. The Si 204D was produced not just by the French plant, but in the Protectorate of Bohemia and Moravia (former Czechoslovakia) by Aero, Letov and CKD factories too. The final variety to be developed during the war time was the Si 204E which featured a gun turret and bomb bay in the central section of the fuselage, enabling the type to take part in the bomber crew training or it was even used as a makeshift night fighter. The German Luftwaffe operated the Siebel mainly in so-called B- and C- flight training schools and as a liaison aircraft. The machines which were fitted with radar equipment were used for night fighter training and a handful of the Si 204 was also operated by the Deutsche Luft Hansa during the war.

The end of the Second World War did not bring the career of the type to its end, the Siebel proved to possess marvelous flying capabilities, was reliable and also quite efficient. Several of the Si 204 was taken over by the victorious Allies and were test flown by or even put to regular service with the British RAF, USAAF, Soviet air force, Aeroflot (Soviet Airlines), Czechoslovak air force, ČSA (Czechoslovak Airlines) and French Armée de l'Air and Aéronavale. The post war production went on at both the French SNCAC and Czechoslovak plants. The French machines were known as the NC700 to NC702 and dubbed the Martinet and were also exported to Sweden and Poland. In Czechoslovakia, the various indigenously built versions of the Siebel were put to service as the C-3A/B, C-103 or D-44 respectively. At first, they were to serve for training purposes only, but the 1948 communist coup and various other reasons too meant that no other and more advanced types would be available to replace them eventually, so they went on to serve with the bomber units of the ČSLA (Czechoslovak Air Force) well until the mid 1950s when they were replaced by the Il-28 jets.

Si 204D characteristics and performance:

Wingspan 21.28 m, length 11.95 m, max. speed 364 km/h at 3,000 m, service ceiling 7,500 m, range 1,800 km.

CZ

V roce 1934 založil Hanns Klemm v Halle pobočku své firmy. Ta měla vyrábět, na rozdíl od mateřské továrny, vyrábějící celodřevěné letouny, vícemotorové letouny celokovové konstrukce. V roce 1937 převzal továrnu v Halle známý německý letec Friedrich Siebel a přenesl na ni své jméno. Továrna se zabývala hlavně licenční výrobou, ale konstruovala i vlastní typy. První konstrukcí nové továrny se stal Fh 104 Hallore, který vznikl ještě jako projekt v továrně Klemm.

V roce 1938 vypsal dopravní společnost Lufthansa ve spolupráci s RLM soutěž na rychlý dvoumotorový dopravní letoun. Než byla soutěž ukončena, vypukla válka. O letoun ale jevila stále zájem Luftwaffe. Prototyp letounu označeného Si 204A vzletl poprvé 23. 5. 1941. Tento dvoumotorový celokovový letoun byl poháněn dvojicí motorů Argus As 411 a od všech pozdějších verzí se odlišoval tím, že měl stupněnou před. Byl zaveden do výroby, ale protože továrna v Halle byla vytižena výrobou Ju 88, byla výroba přenesena do Société Nationale de Constructions Aéronautiques du Nord (SNCAN) ve Francii. Třetí prototyp byl vyroben jako nová verze Si 204D. Odlišoval se celoprosklenou předí, podobnou jakou byly vybaveny bombardovací letouny He 111 H/P nebo Ju 88A. Hodil se tak skvěle k výcviku. I jeho výroby byla předána do SNCAN ve Francii a také do továren Aero, Letov a ČKD v Protektorátu Čechy a Morava. Poslední verzi vyvinutou za války byla Si 204E, vybavená střeleckou věží a pumovnicí v centropláně. Ta byla určena k bombardovacímu výcviku. Nouzově mohla být použita i jako noční bombardér. Luftwaffe používala Si 204 hlavně v tzv. B a C školách a jako spojovací. Stroje vybavené radarem sloužily k výcviku nočního stíhání. Několik kusů používala během války i Lufthansa.

Konec války ale neznamenal konec historie Si 204. Siebel Si 204 měl skvělé letové vlastnosti, byl spolehlivý a výkonný. Dost letounů zabavili vítězové. Ukořistěné Si 204 tak testovaly nebo používaly britská RAF, USAAF, sovětské letectvo i Aeroflot, Československé letectvo i ČSA a francouzské Armée de l'Air i Aéronavale. Výroba ve Francii u SNCAC pokračovala i po válce, stejně jako v Československu. Ve Francii vyráběný Si 204 v několika verzích byl označen NC 700 až 702 pojmenován Martinet. Byl dokonce exportován do Švédska a Polska. Československé Si 204 byly označovány podle verze C-3A/B, C-103 a D-44. Jejich výroba pro nově budované československé letectvo i státní aerolinie ČSA se rozeběhla hned po válce. Měly být používány jen k výcviku. Díky komunistickému převratu a nemožnosti je nahradit z různých důvodů jinými typy tvořily ale výzbroj bombardovacích jednotek ČSLA až do jejich náhrady proudovými Il-28 v polovině padesátých let.

Si 204D TTD

Rozpětí 21,28 m, délka 11,95 m, max. rychlost 364 km/h ve výšce 3 000 m, praktický dostup 7 500 m, dolet 1 800 km.

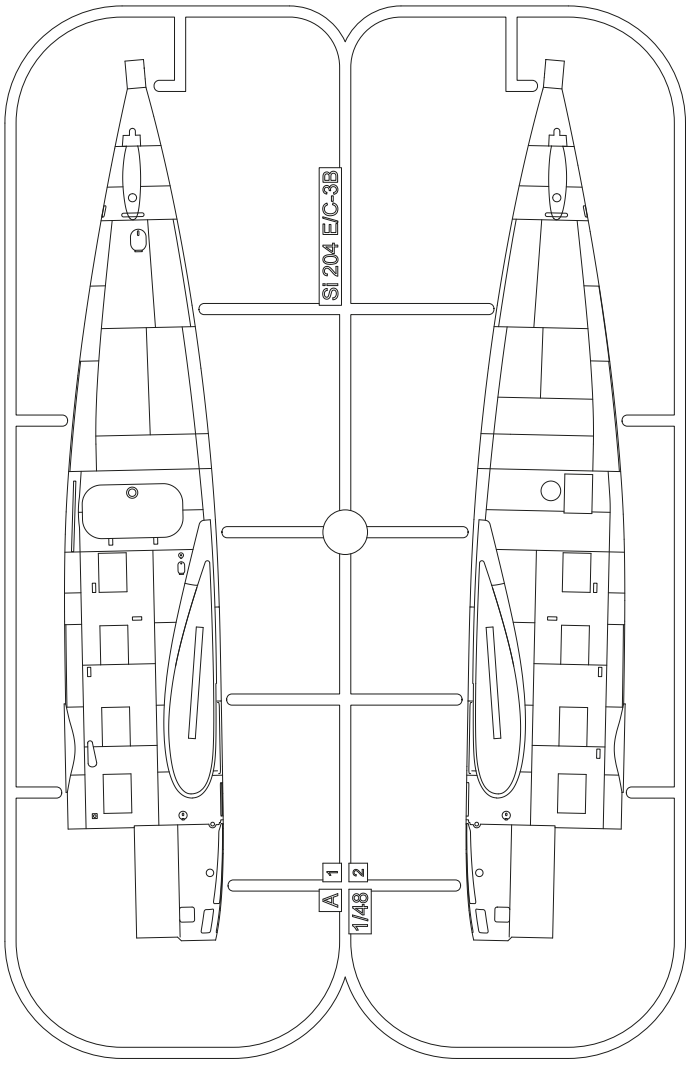

A B

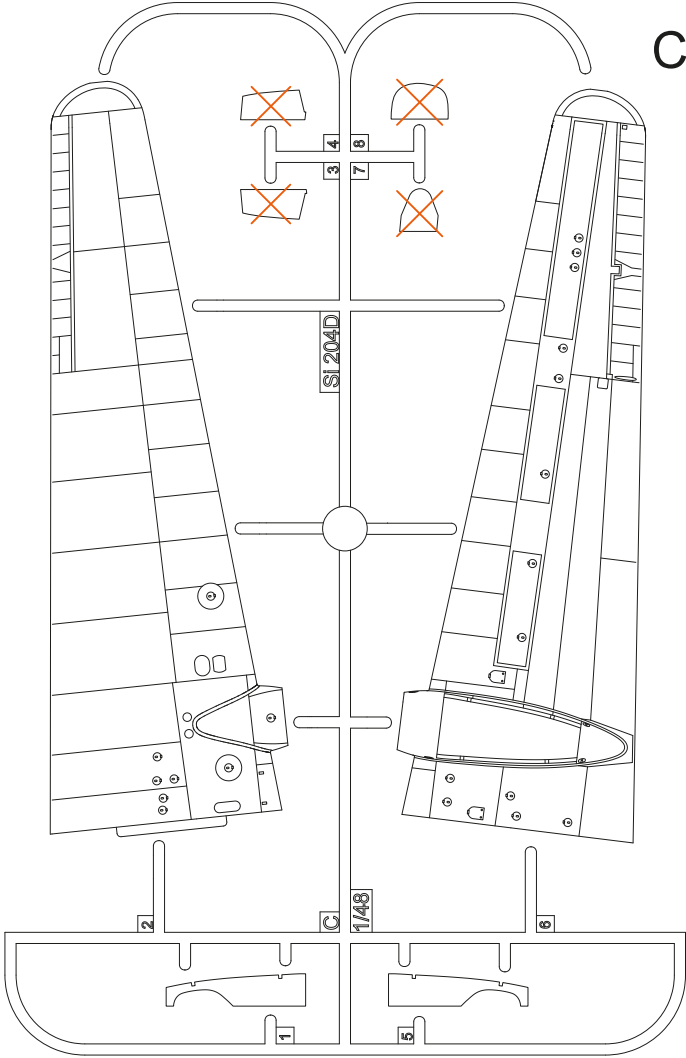
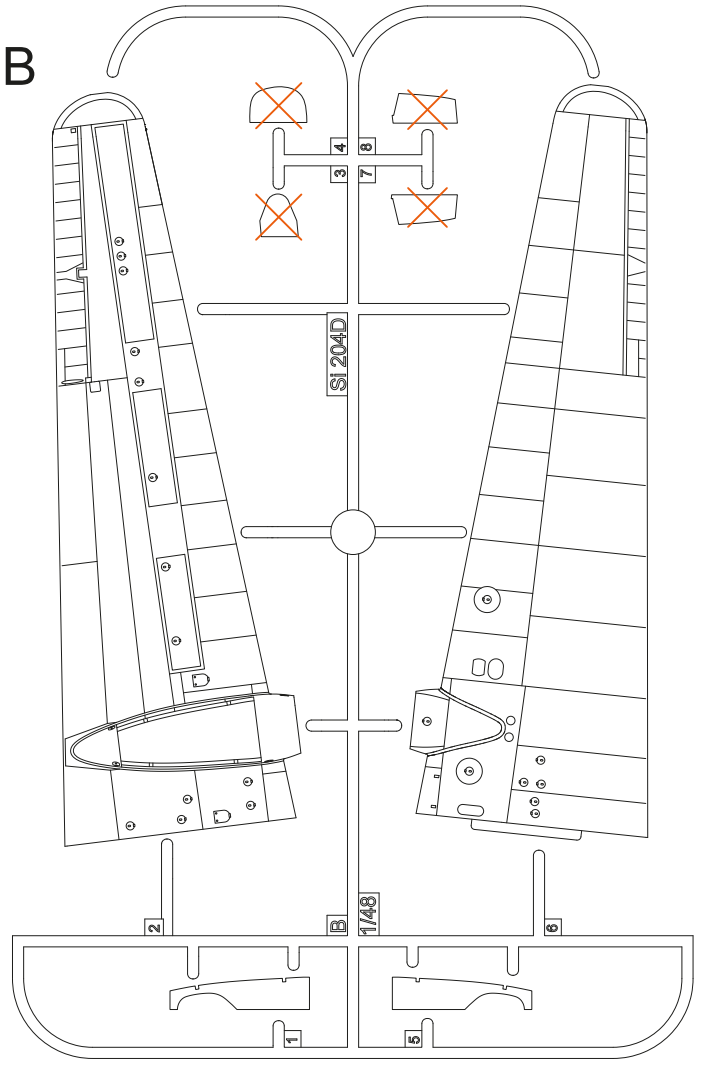

C D

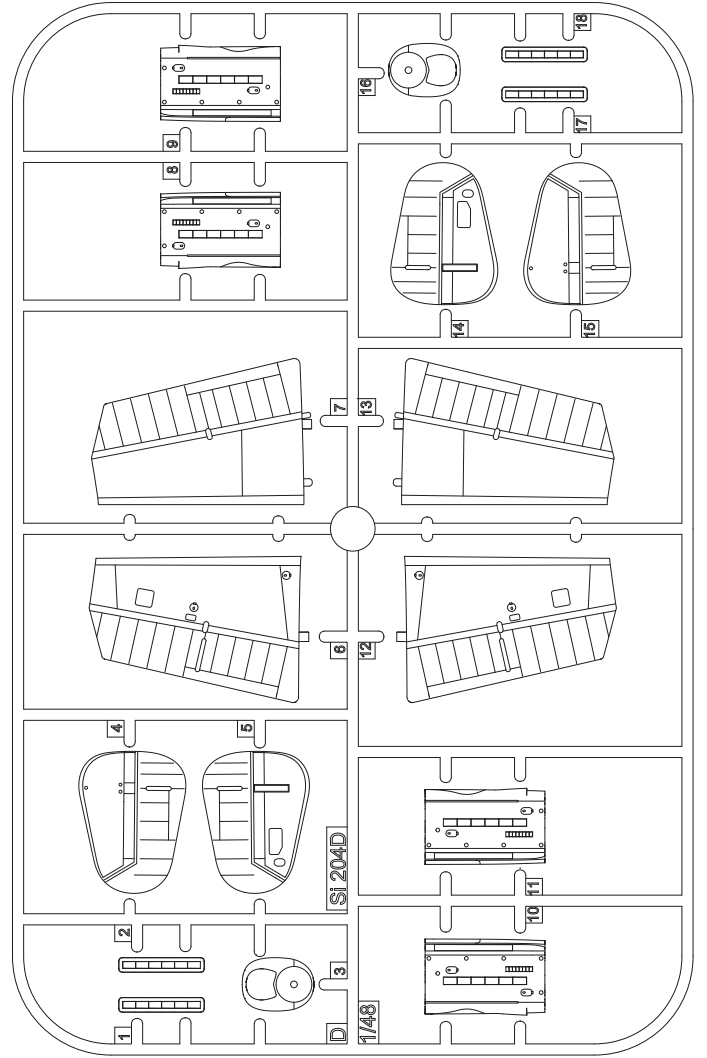

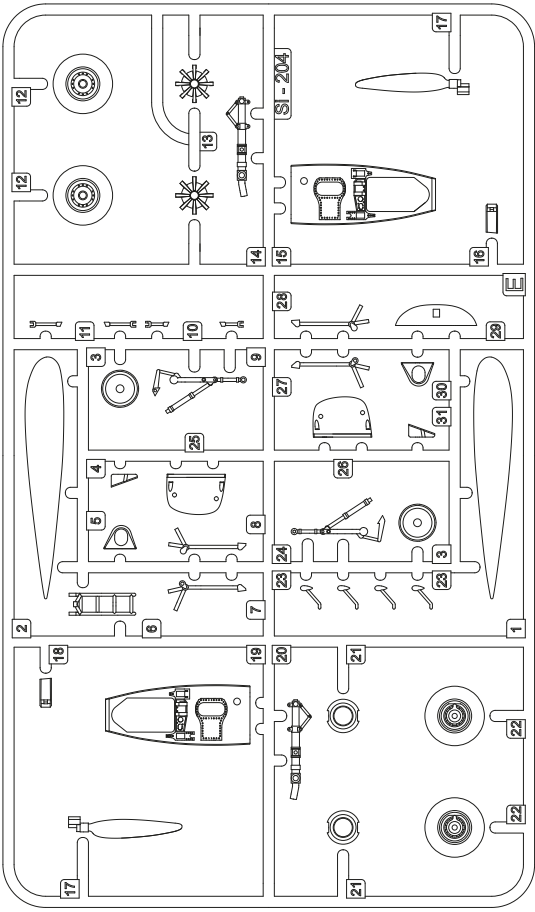

M

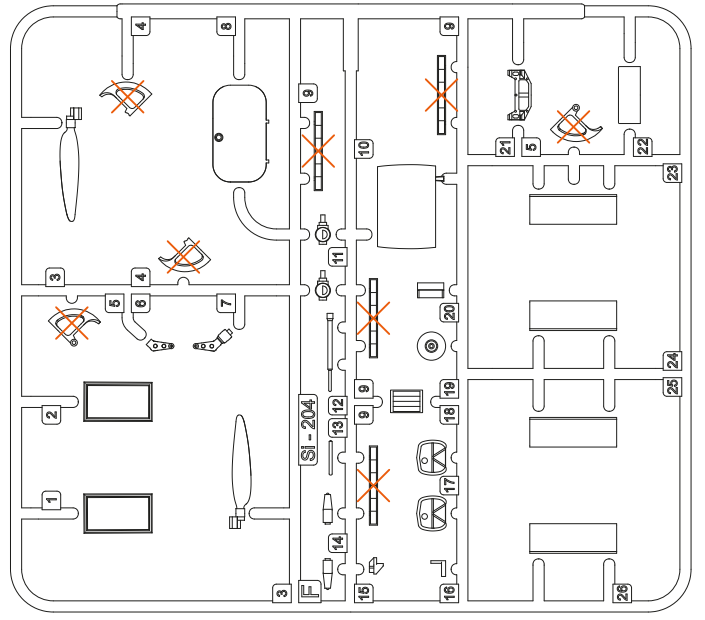

F

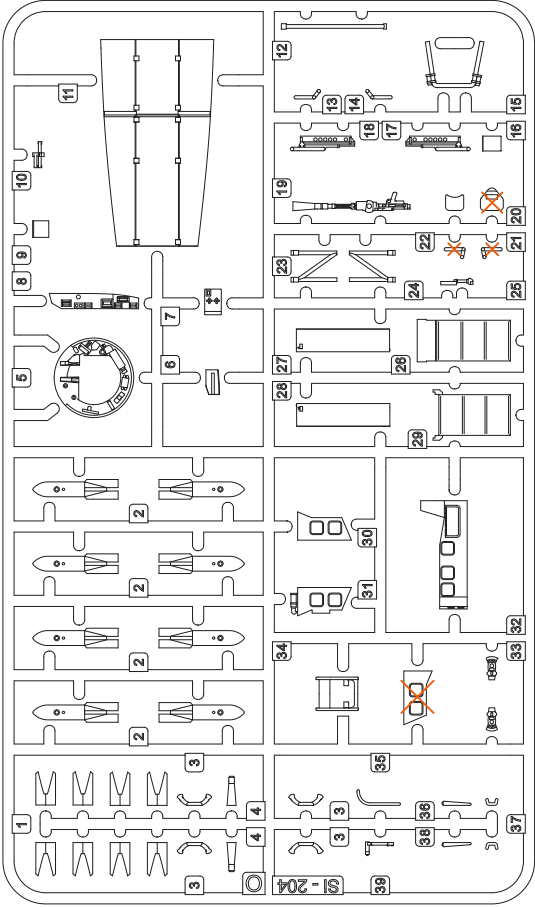

O

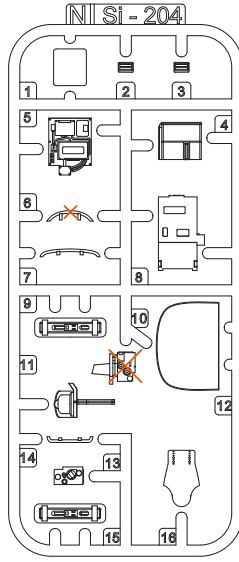

N

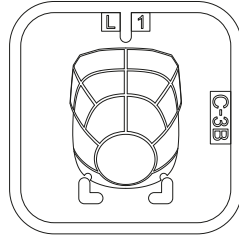

L

M

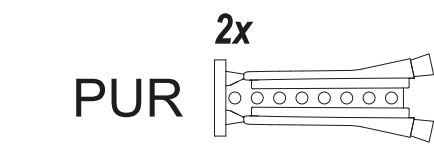
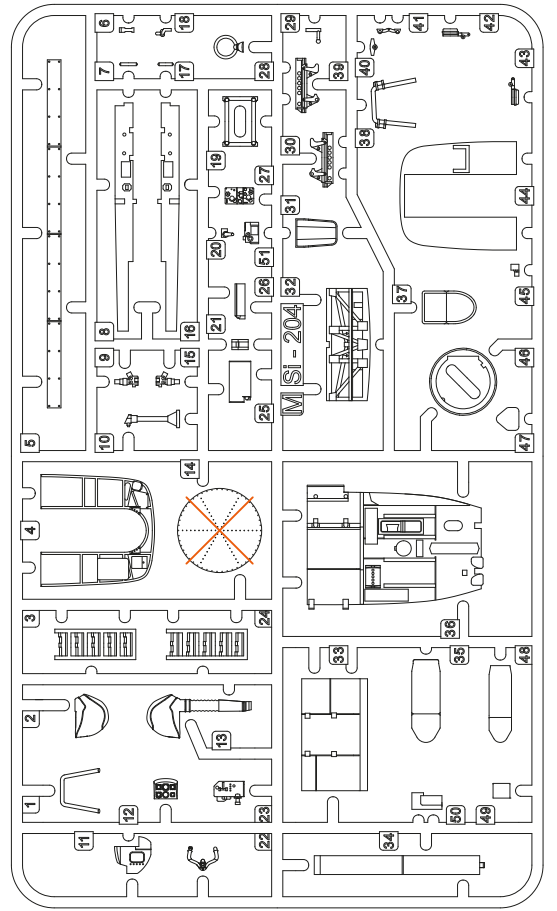

PUR

2x

K

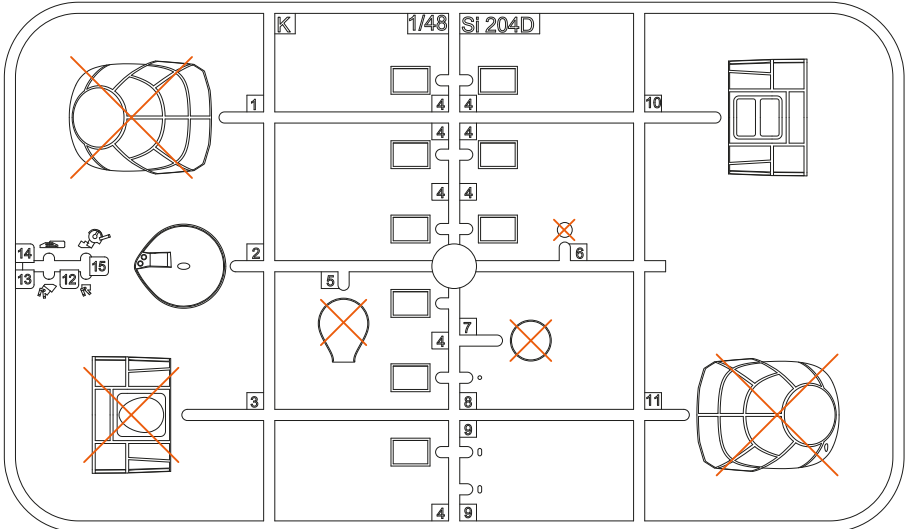

K

STEP 1

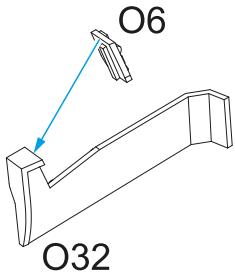

STEP 2

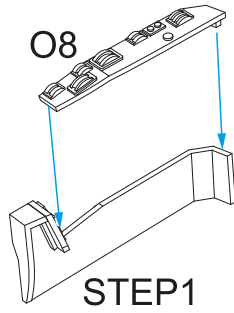

STEP 3

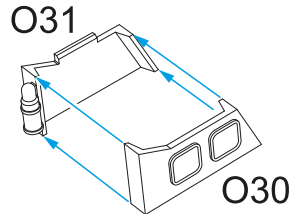

STEP 4

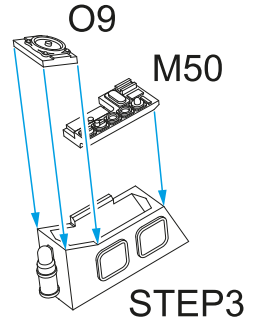

STEP 5

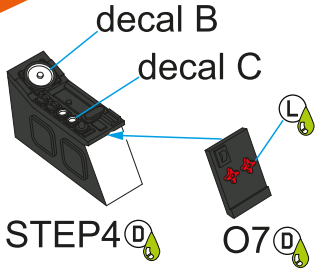

STEP 6

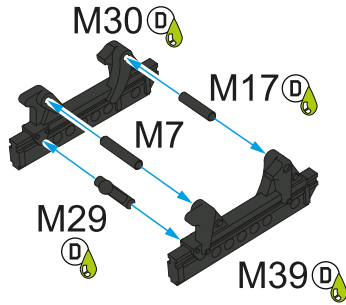

STEP 7

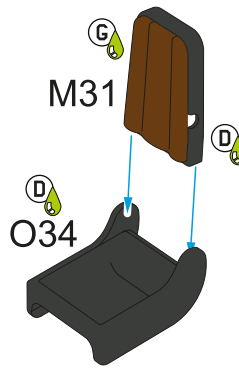

STEP 8

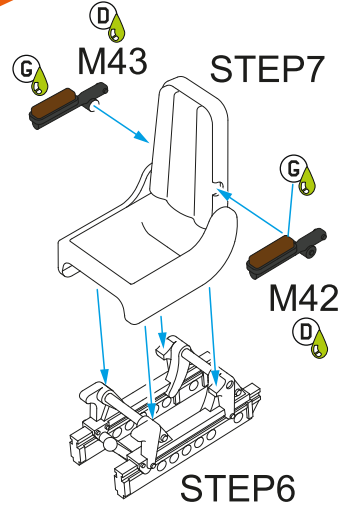

STEP 9

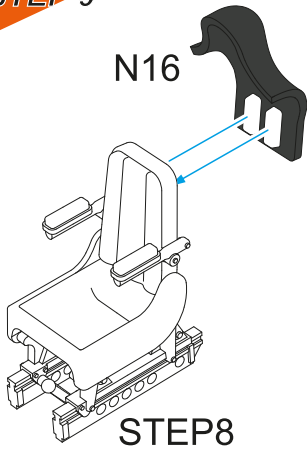

STEP 10

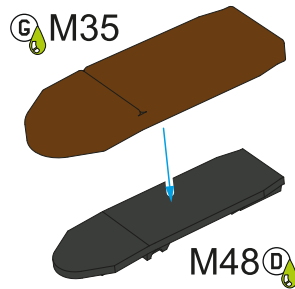

STEP 11

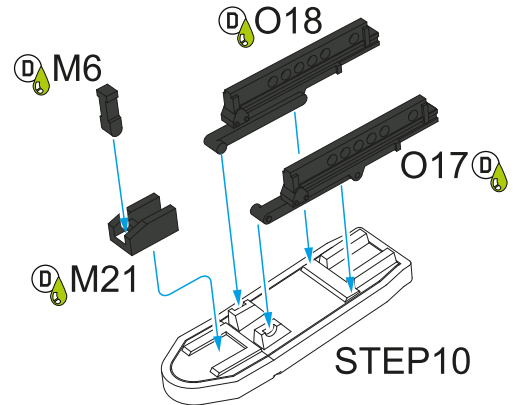

STEP 12

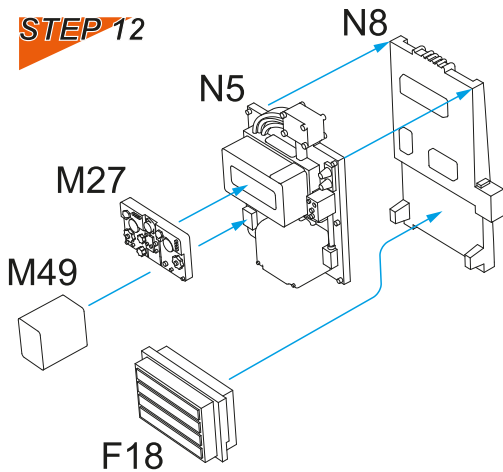

STEP 13

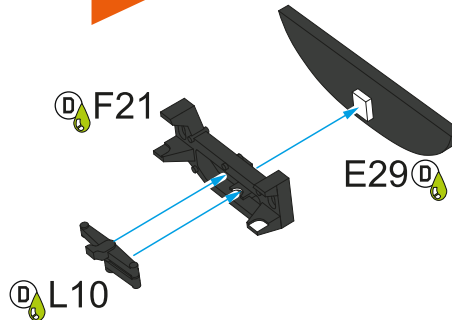

STEP 14a

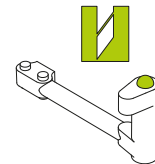

STEP 14b

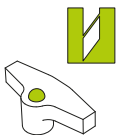

STEP 15

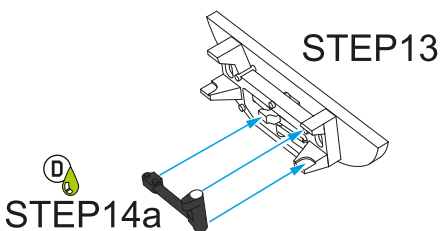

STEP 16

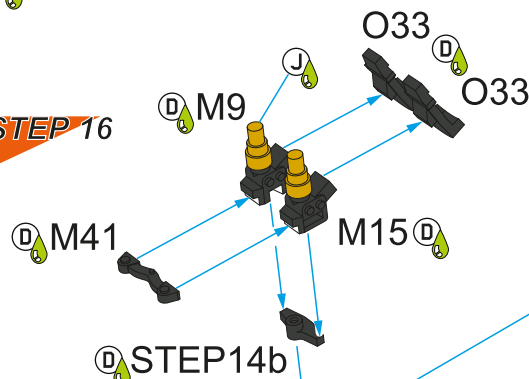

STEP 17

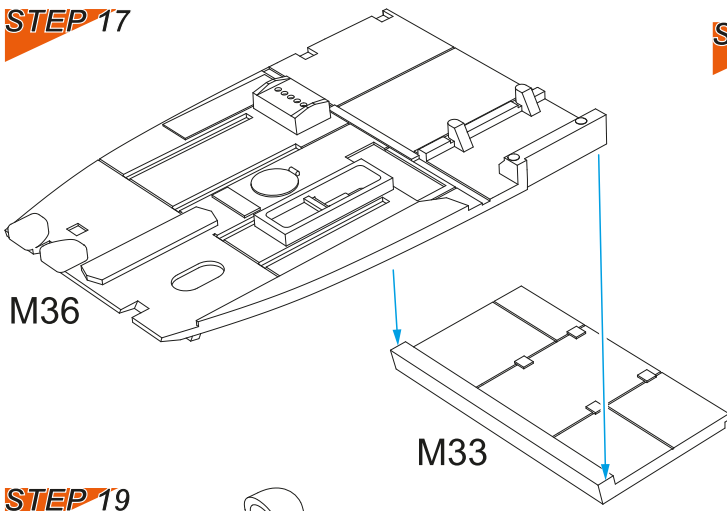

STEP 18

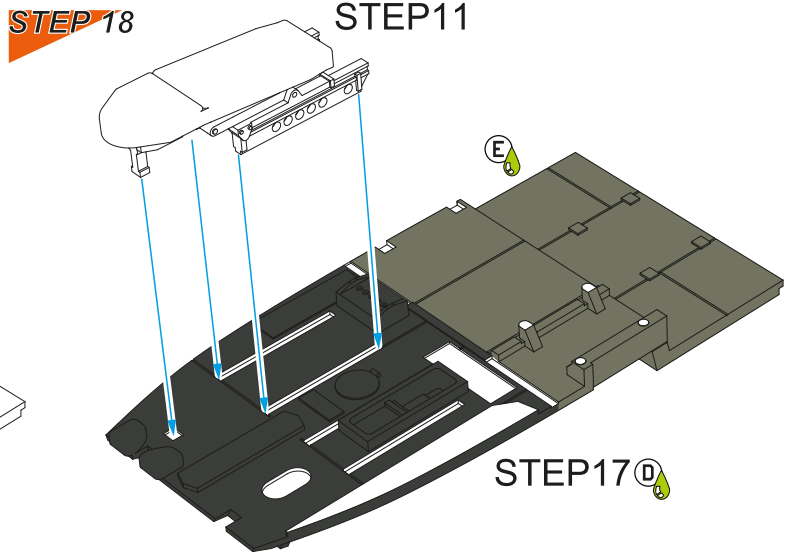

STEP 19

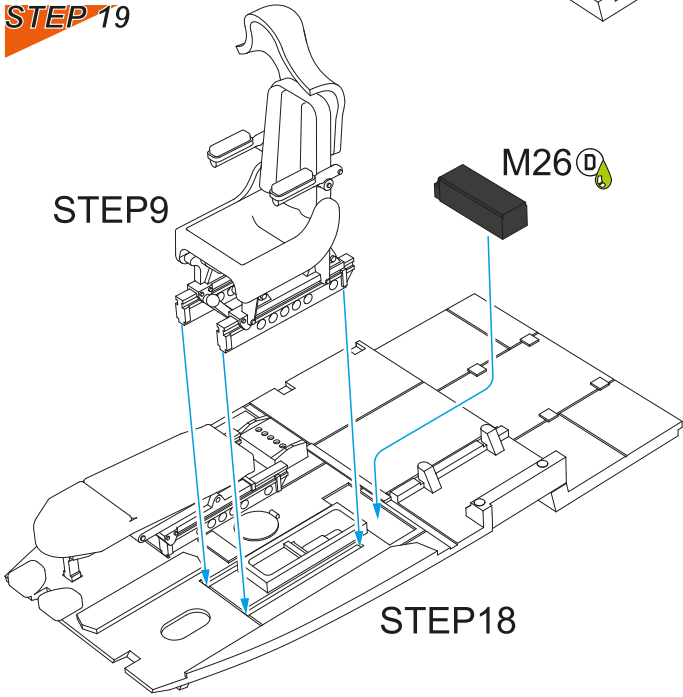

STEP 20

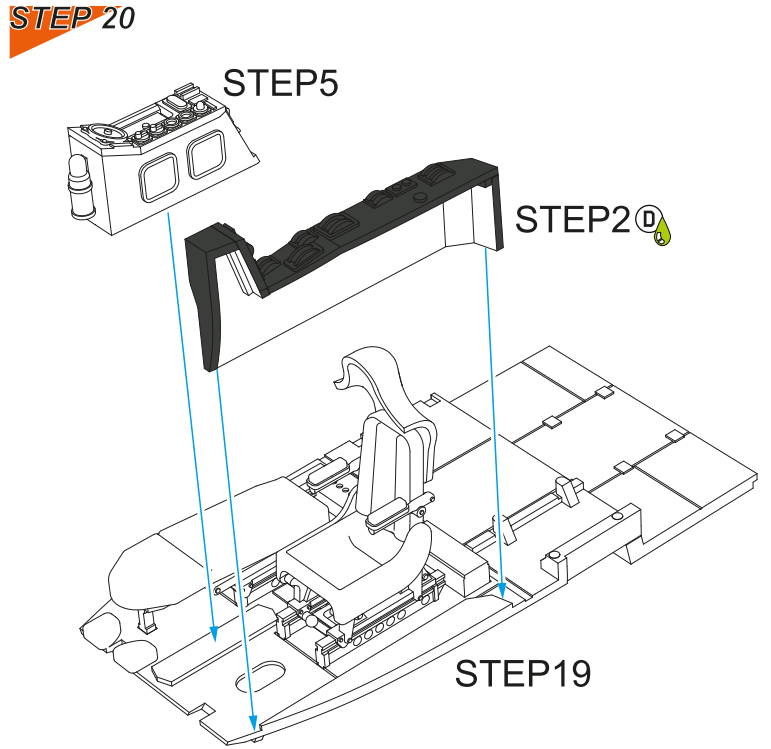

STEP 22

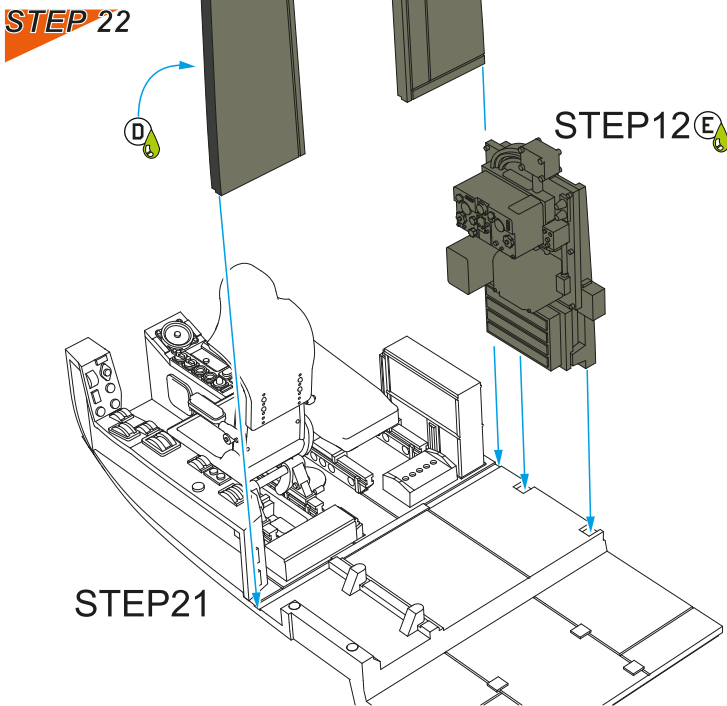

STEP 21

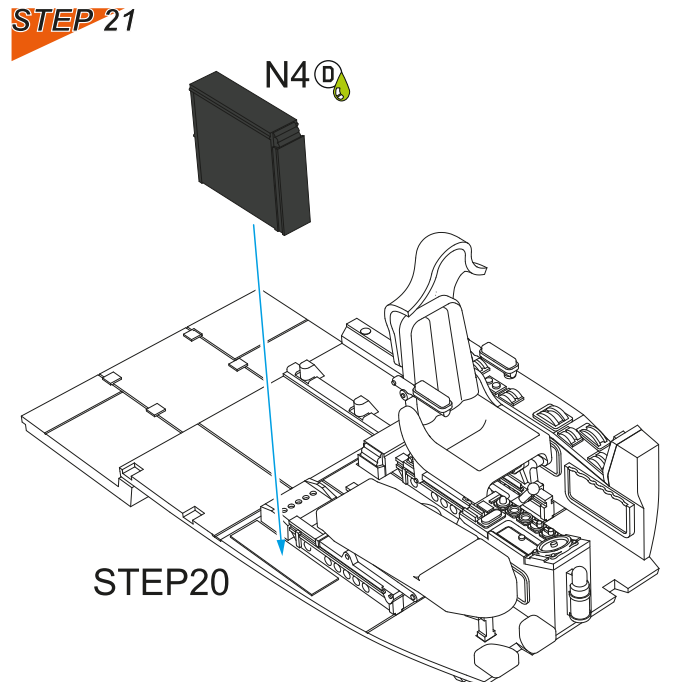

STEP 23

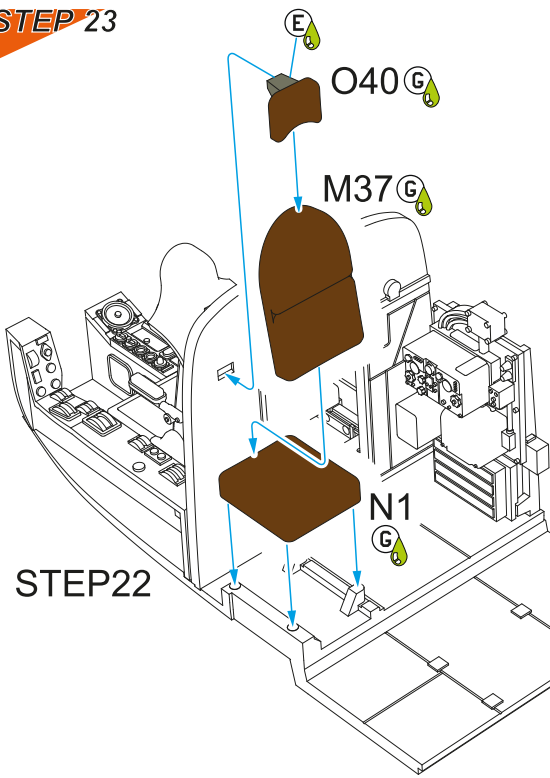

STEP 24

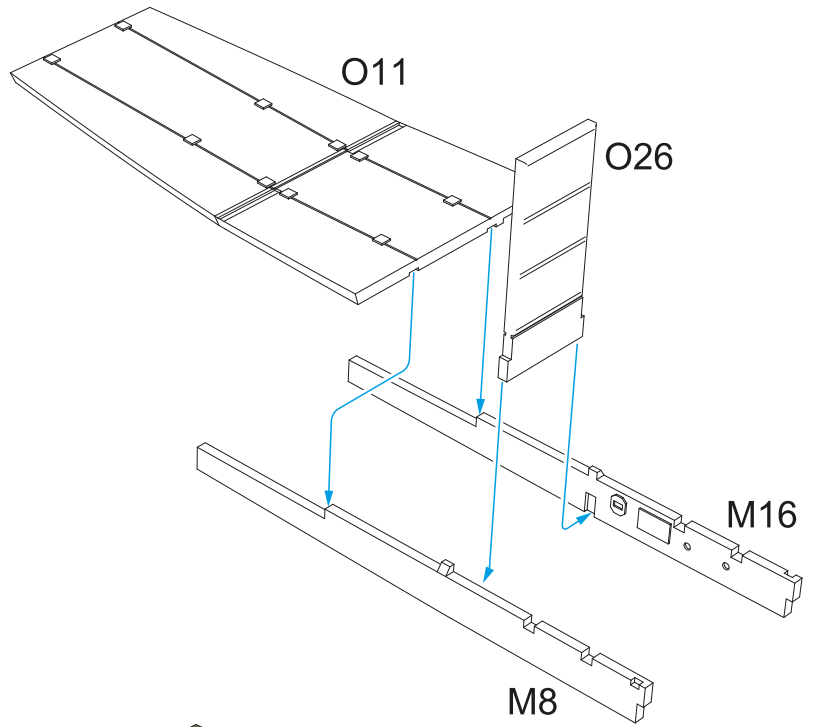

STEP 25

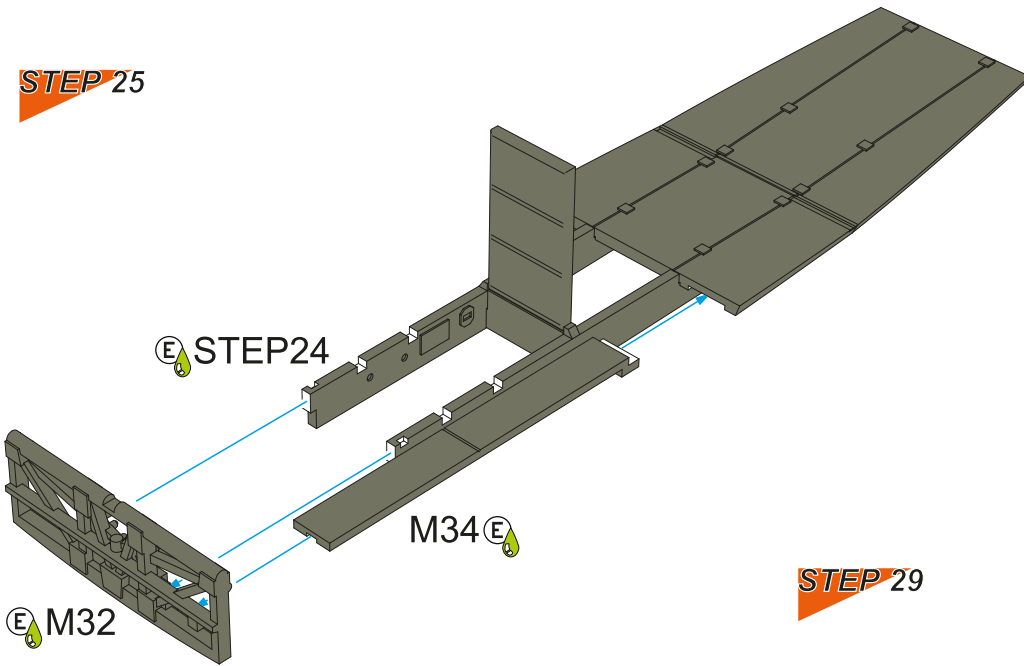

STEP 26

8x

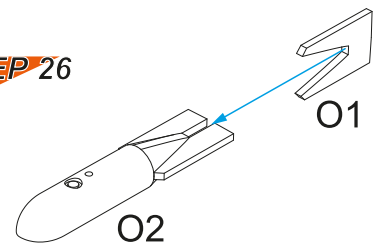

STEP 29

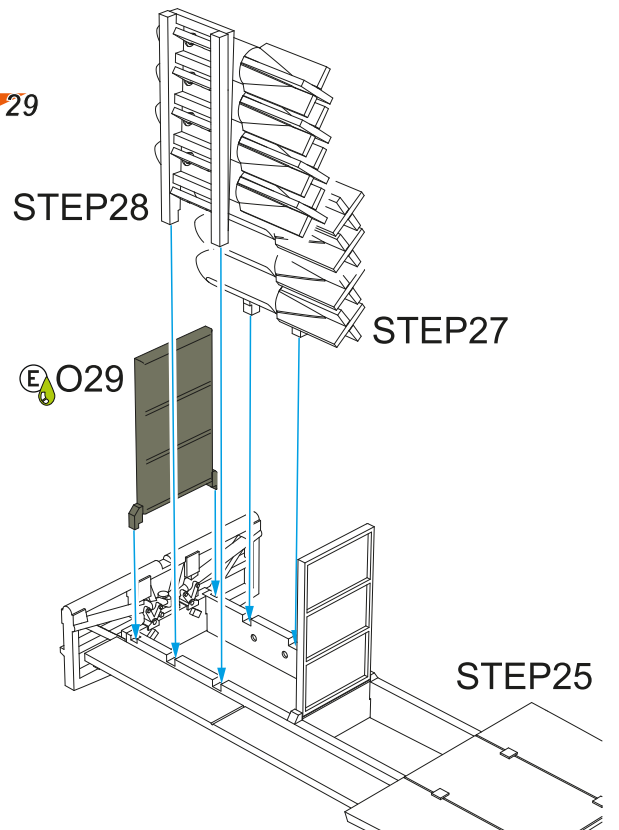

STEP 27

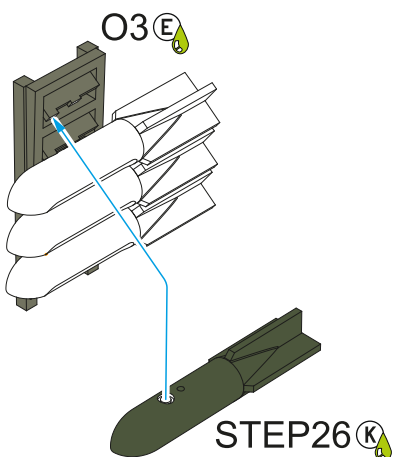

STEP 28

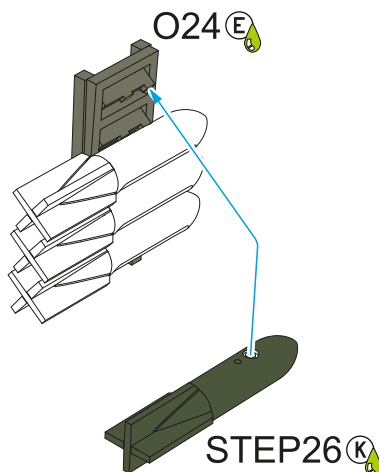

STEP 30

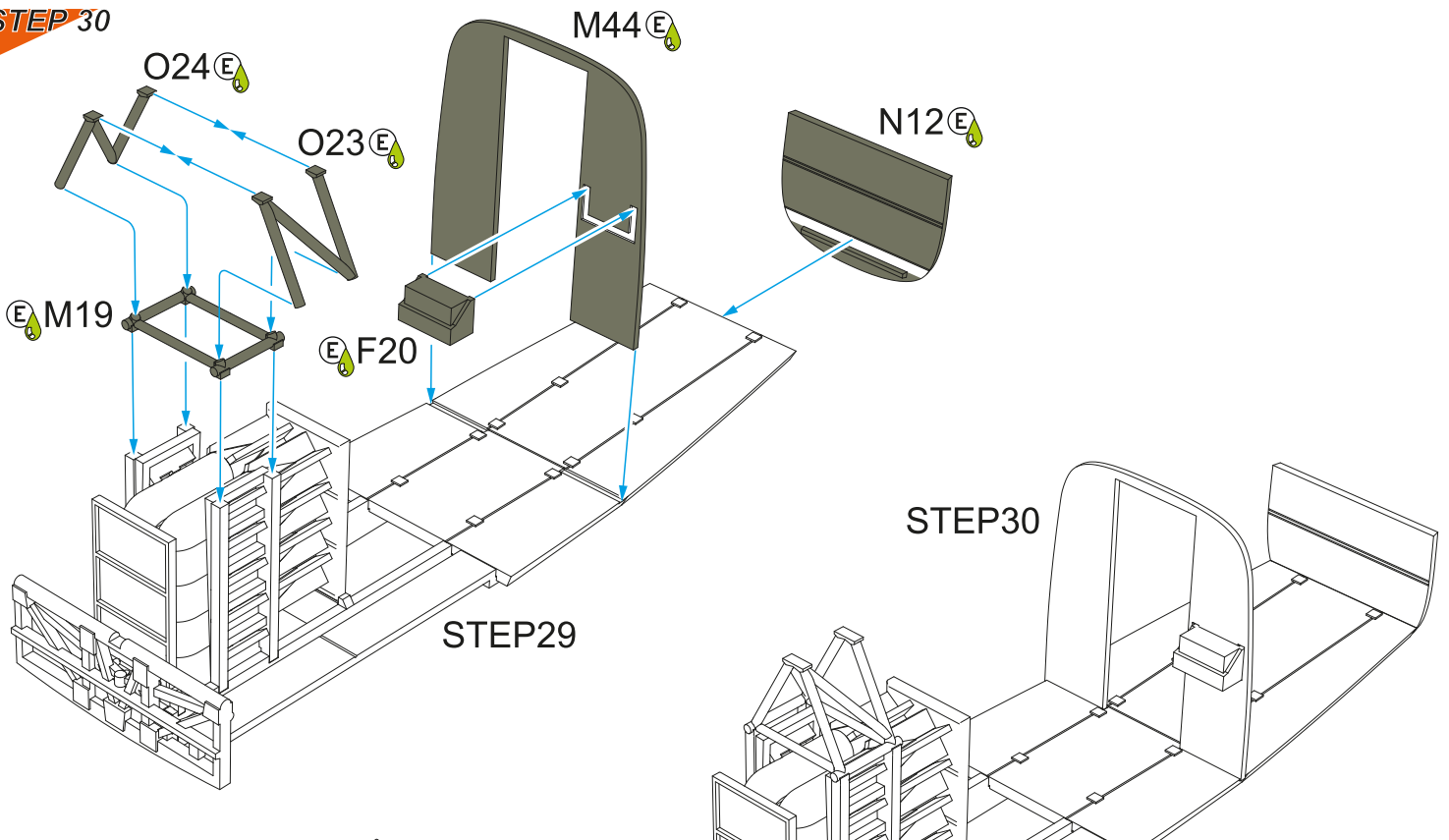

STEP 31

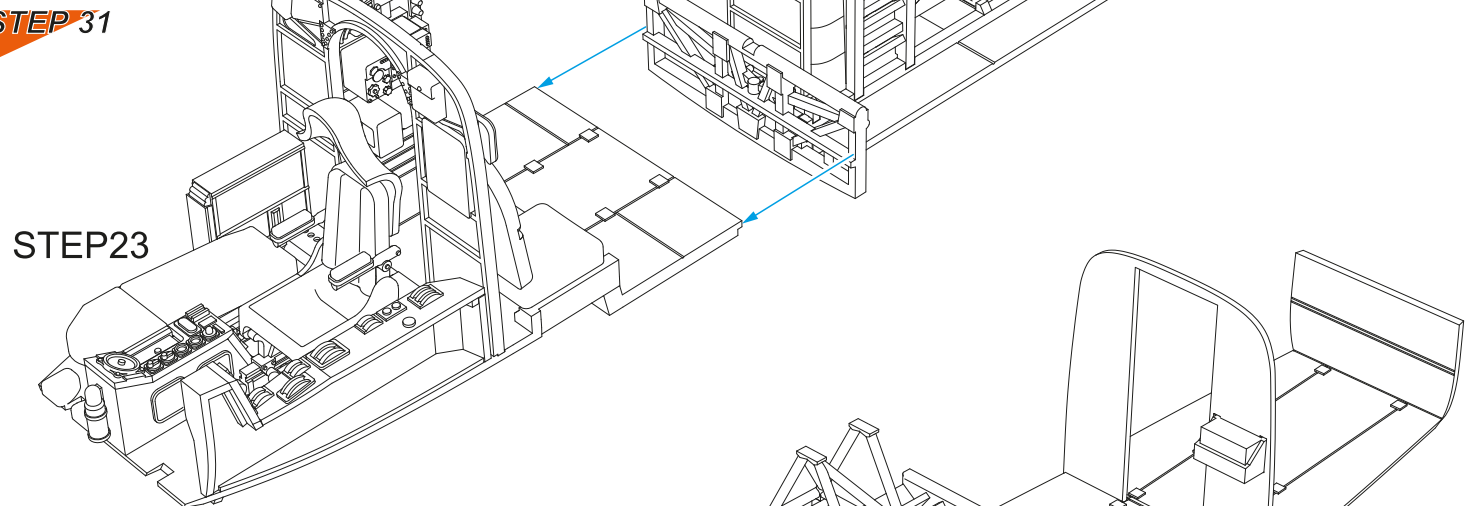

STEP 32

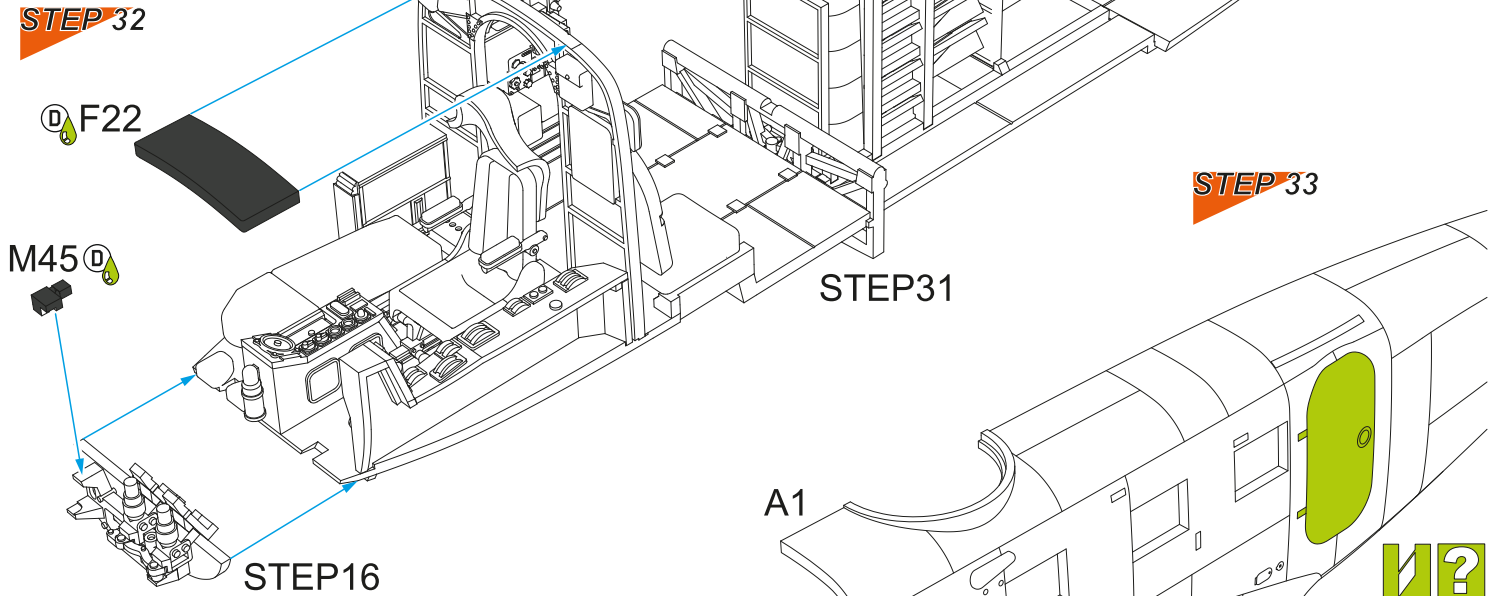

STEP 33

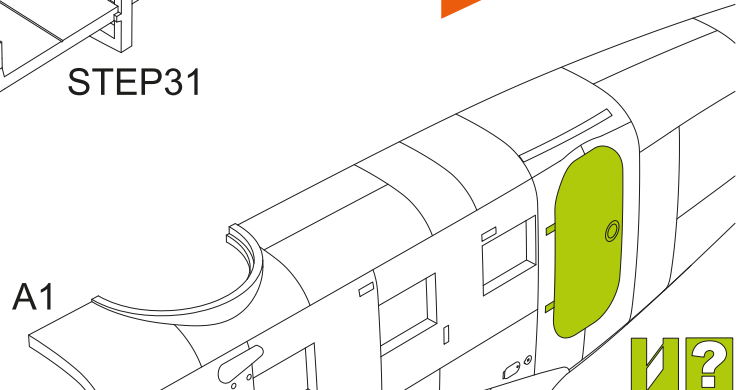

STEP 34



STEP33/ A1

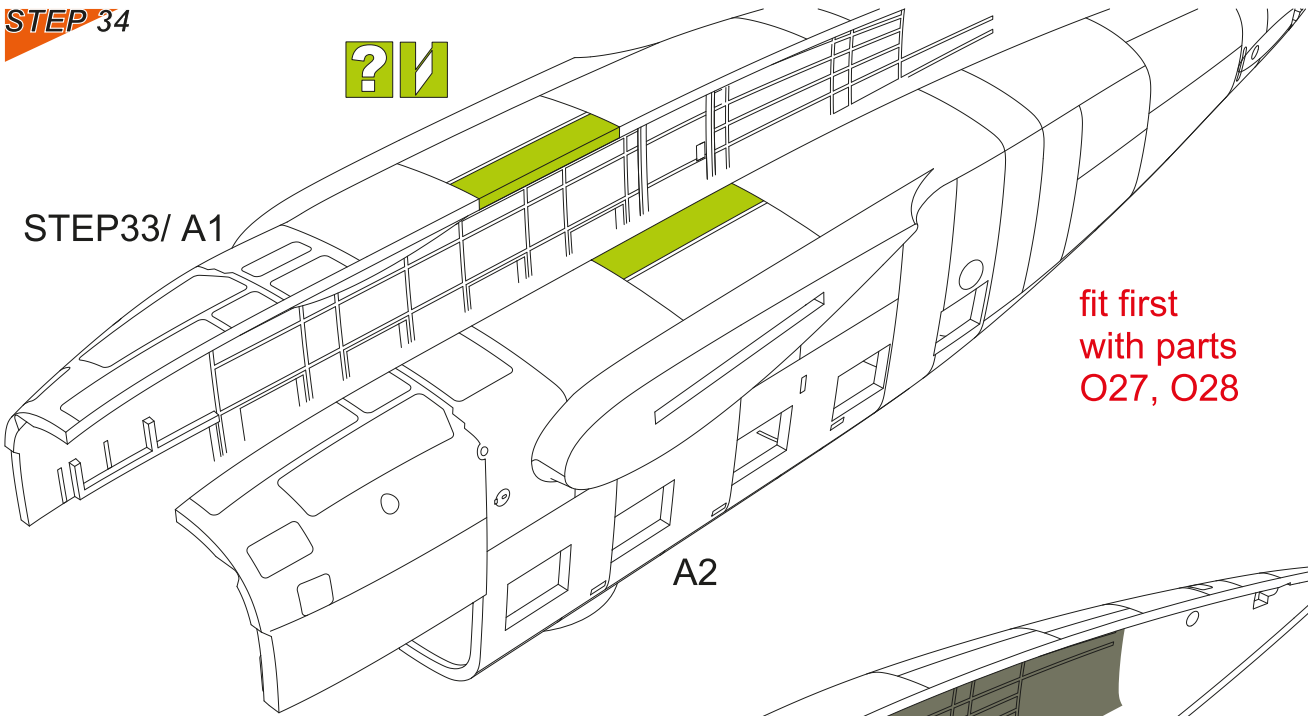

fit first
with parts
O27, O28

A2

STEP 35

STEP34/ A2

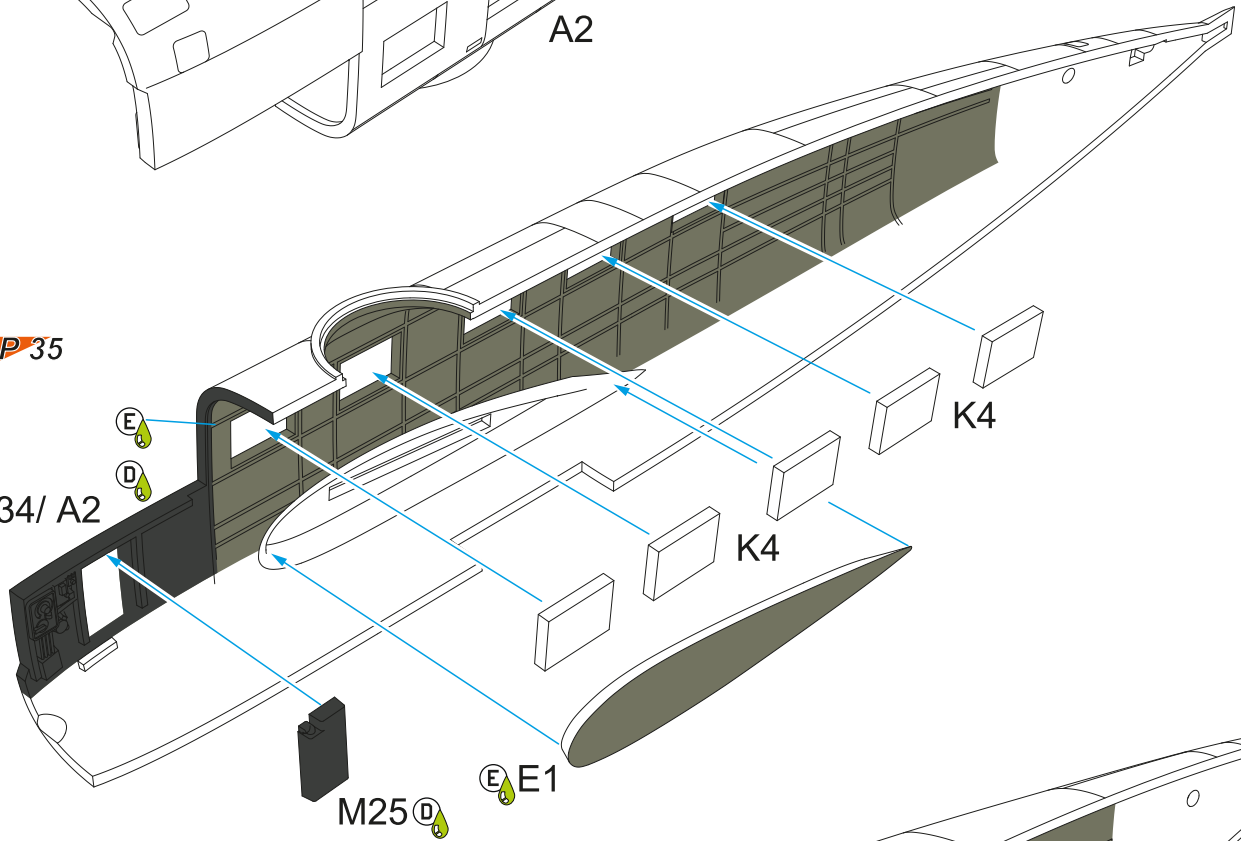

E

D

K4

K4

M25 (D)

E E1

STEP 36

STEP34/ A1

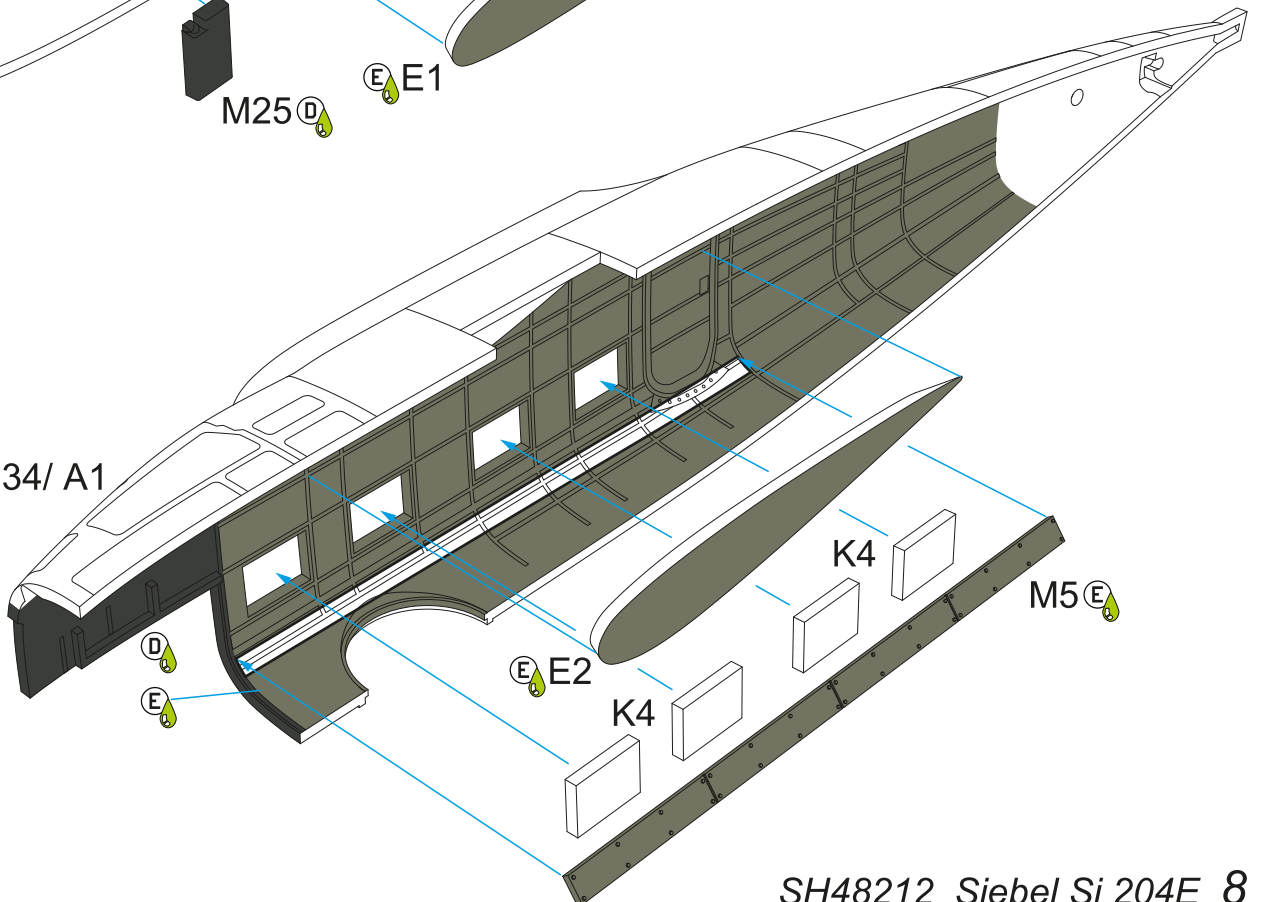

D

E

K4

M5 (E)

E E2

K4

STEP 37

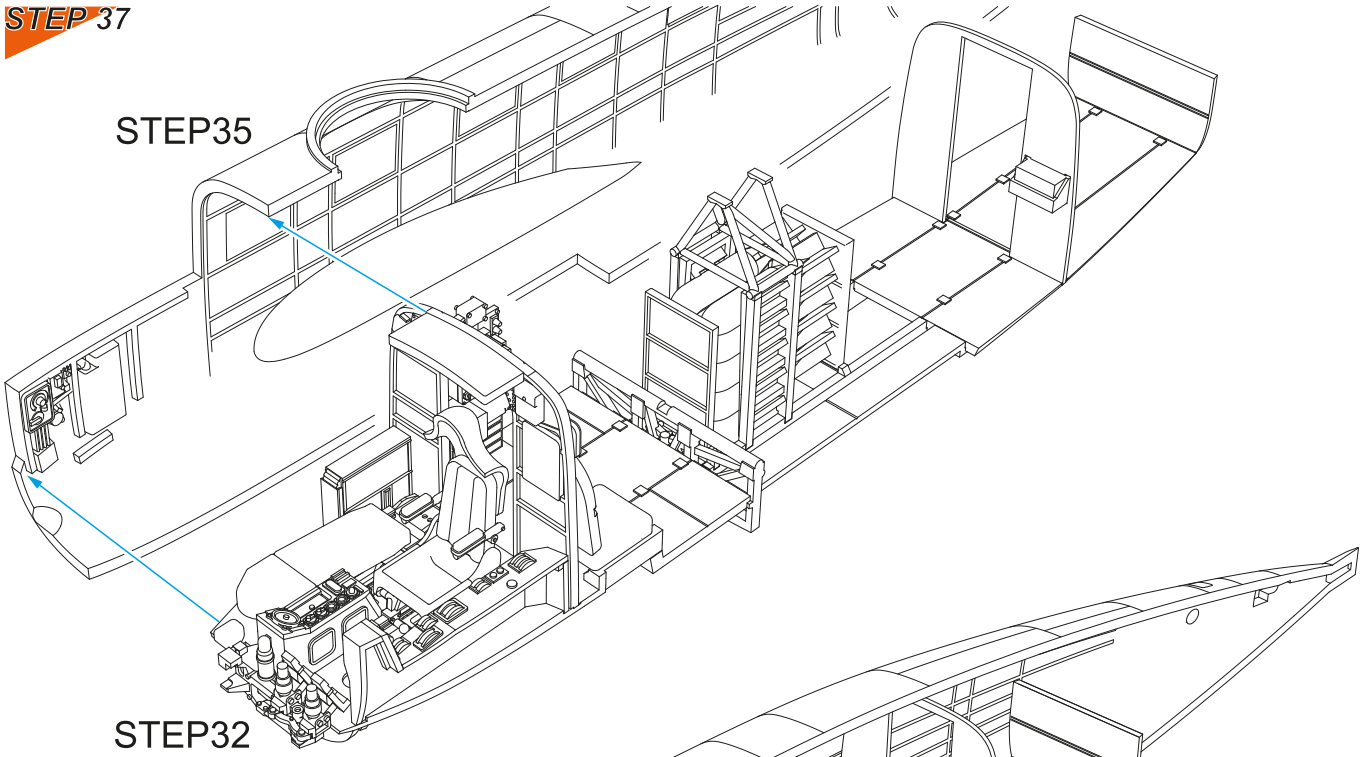

STEP 38

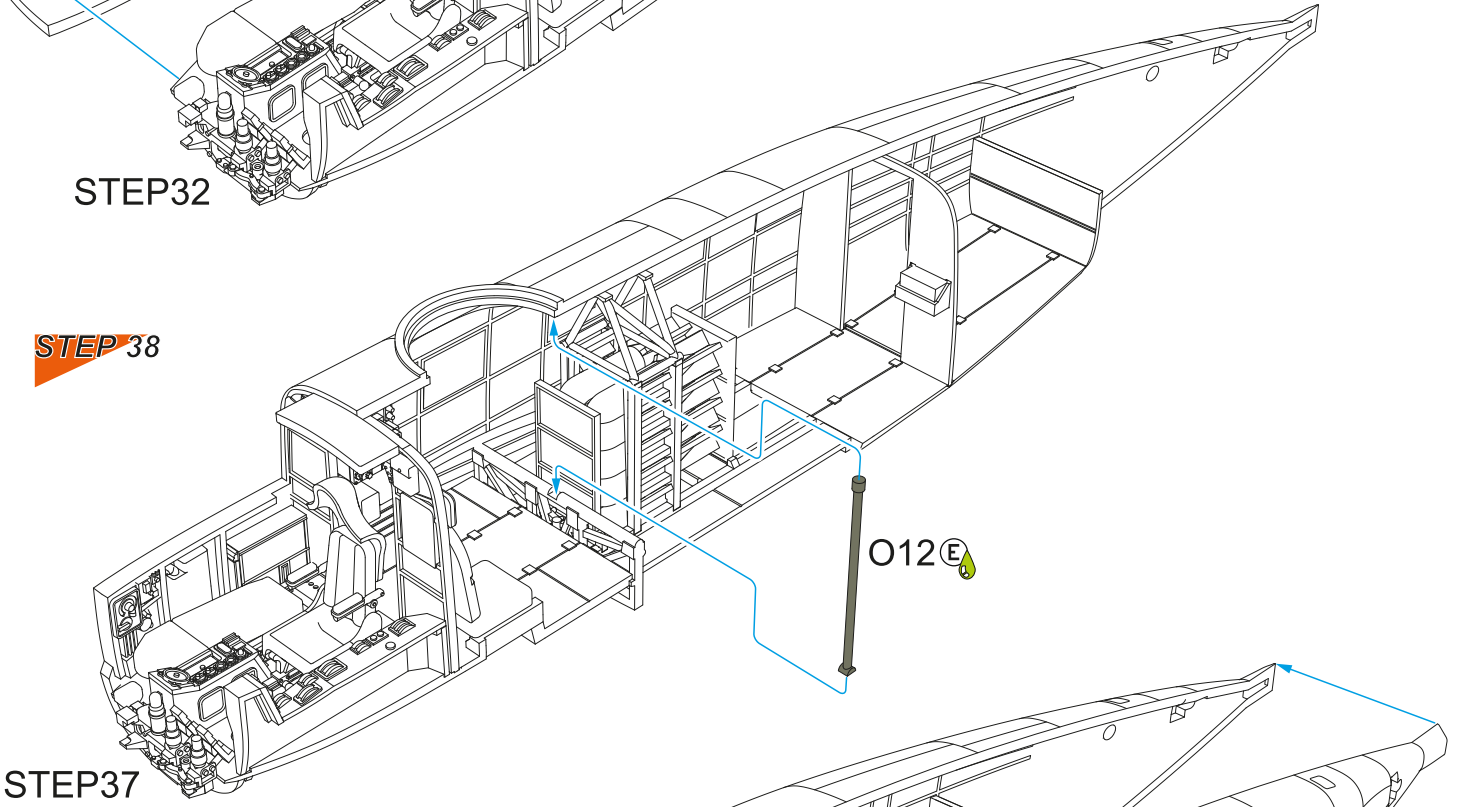

STEP 39

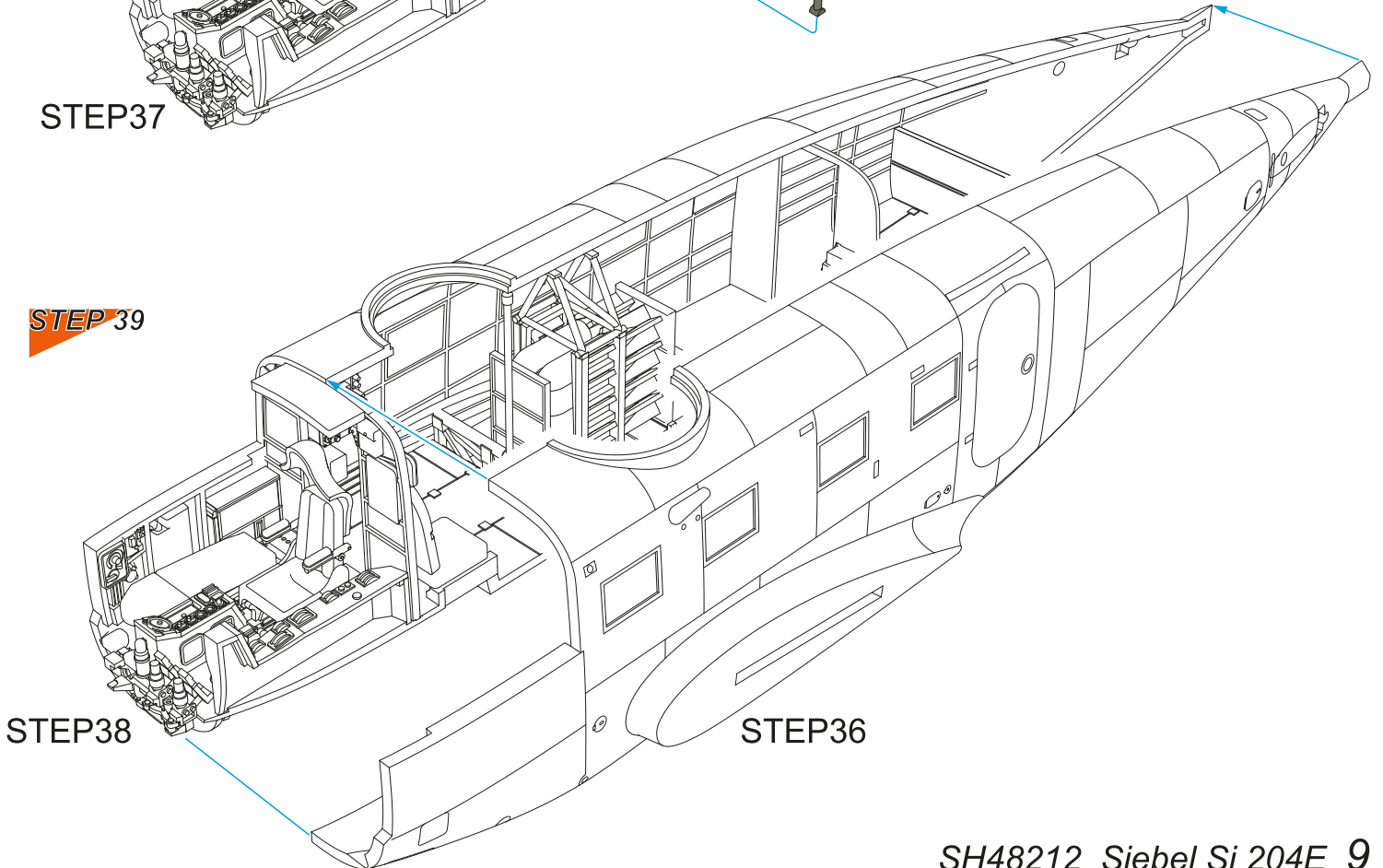

STEP 40

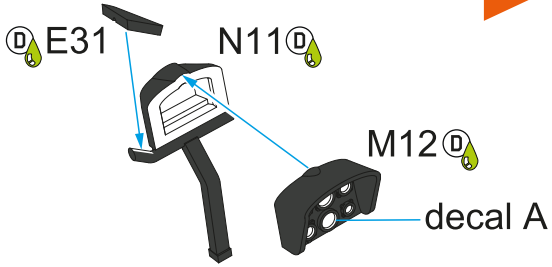

STEP 41

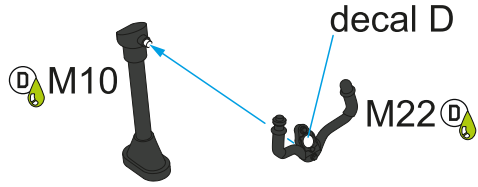

STEP 42

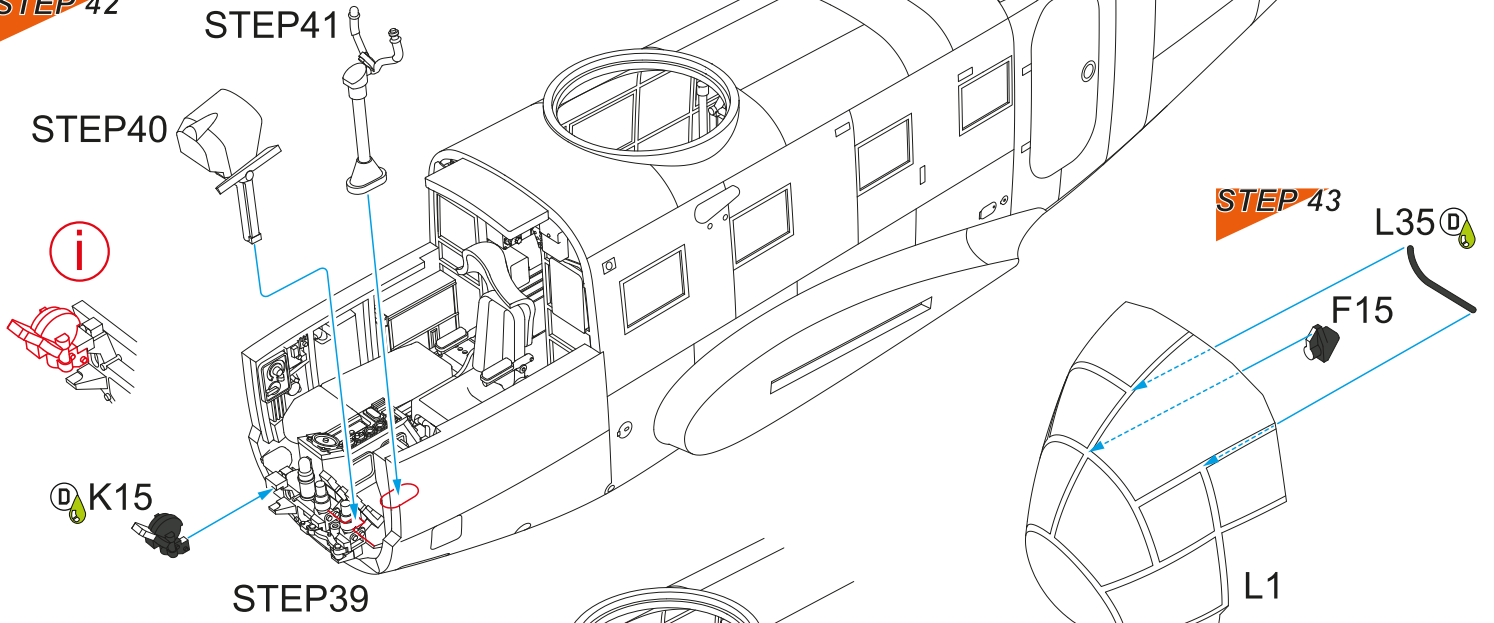

STEP 43

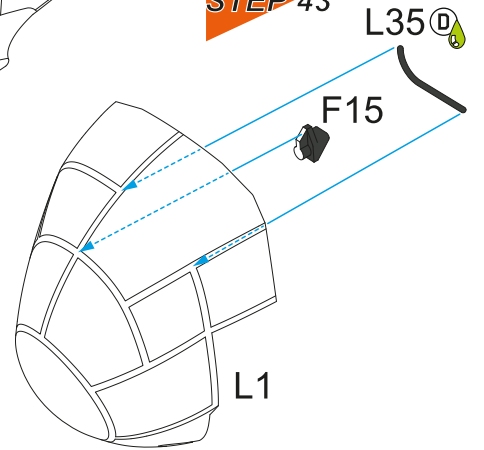

STEP 45

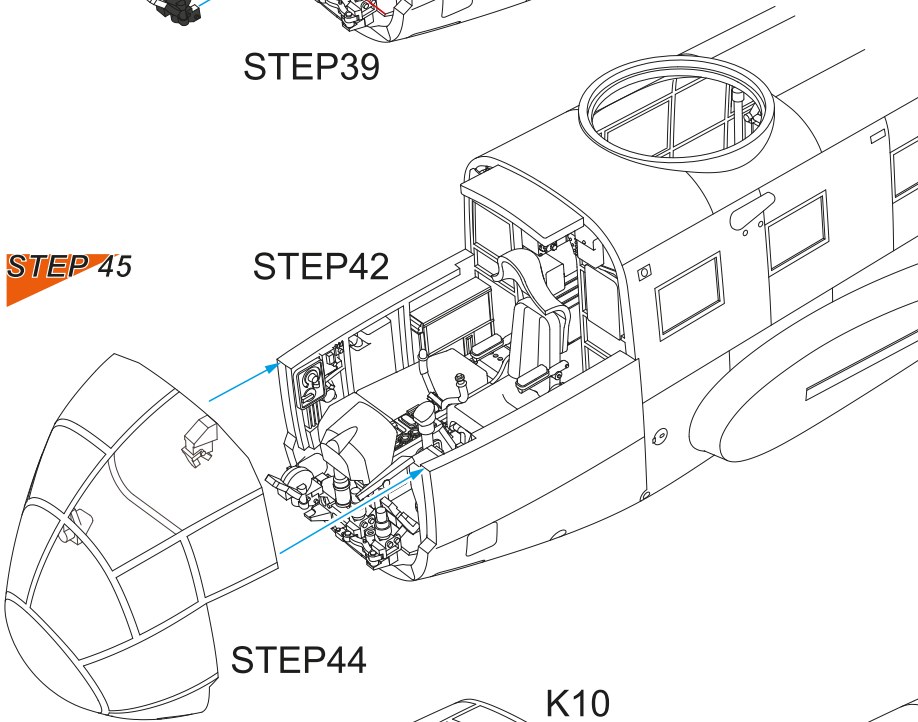

STEP 44

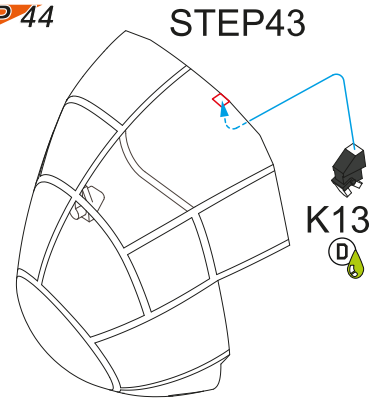

STEP 46

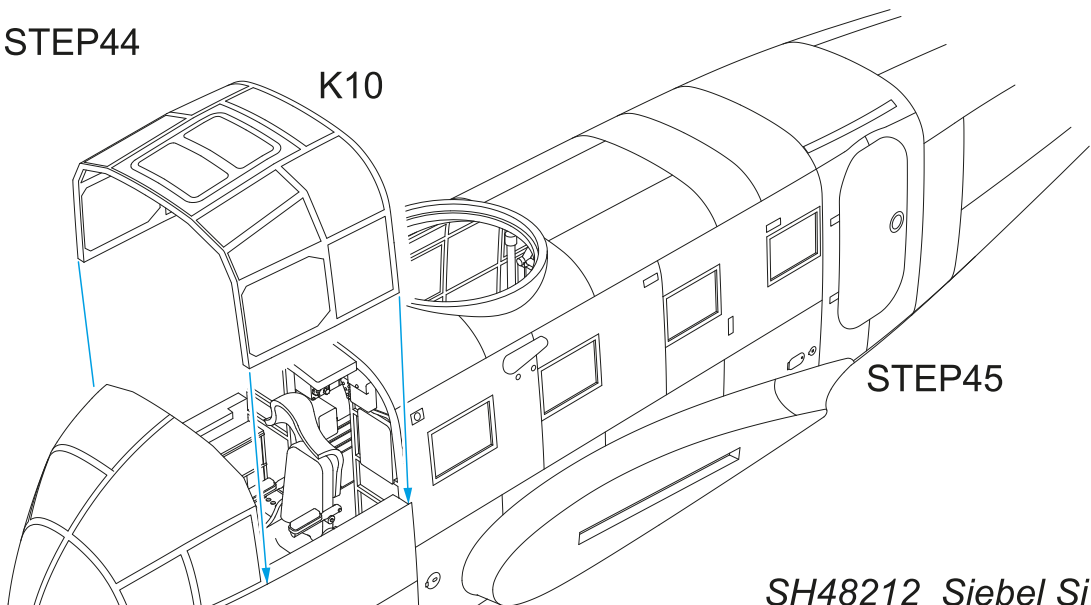

STEP 47

E C6/ B2 opposite

E E26/ E25 opposite

Dry fit first

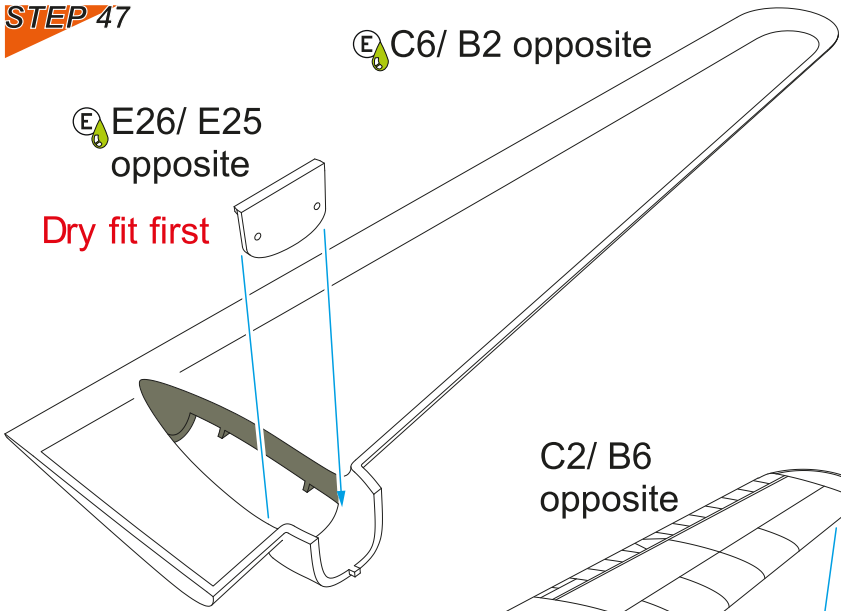

C2/ B6 opposite

STEP 48

E18/ E16 opposite

E1/ E2 opposite

E19/ E15 opposite

E E5/ E30 opposite

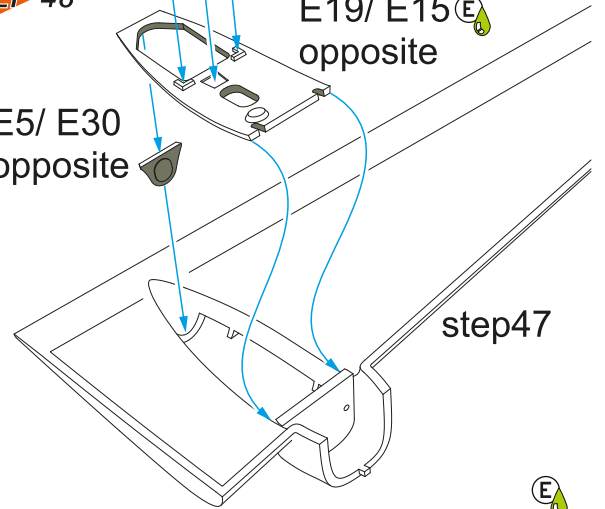

step47

STEP 49

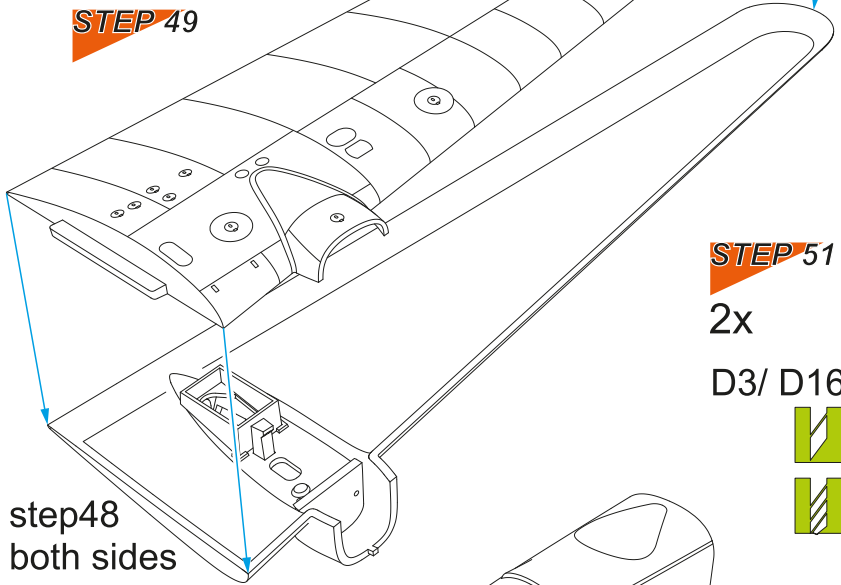

step48 both sides

STEP 51

2x

D3/ D16



STEP 50

F23/ F24

F25/ F26

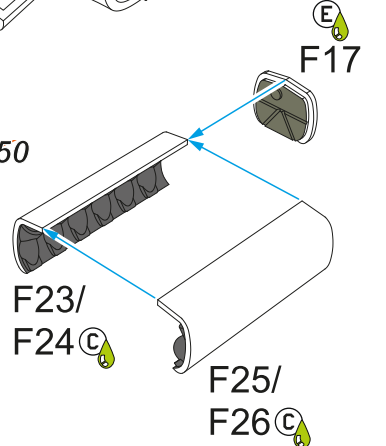

E F17

STEP 52 Scheme B, C

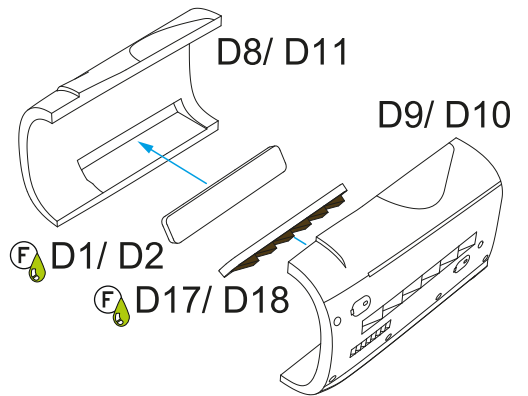

STEP 53

2x

step52 both sides

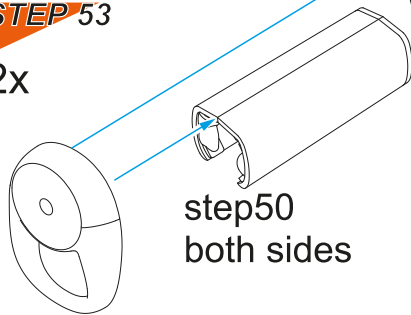

step50 both sides

step51 both sides

STEP 54

step49 both sides

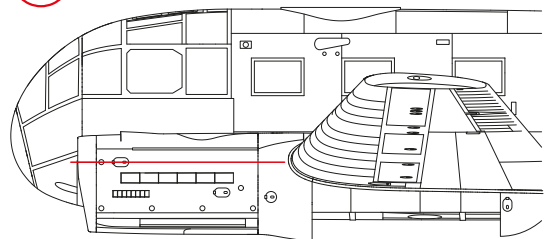
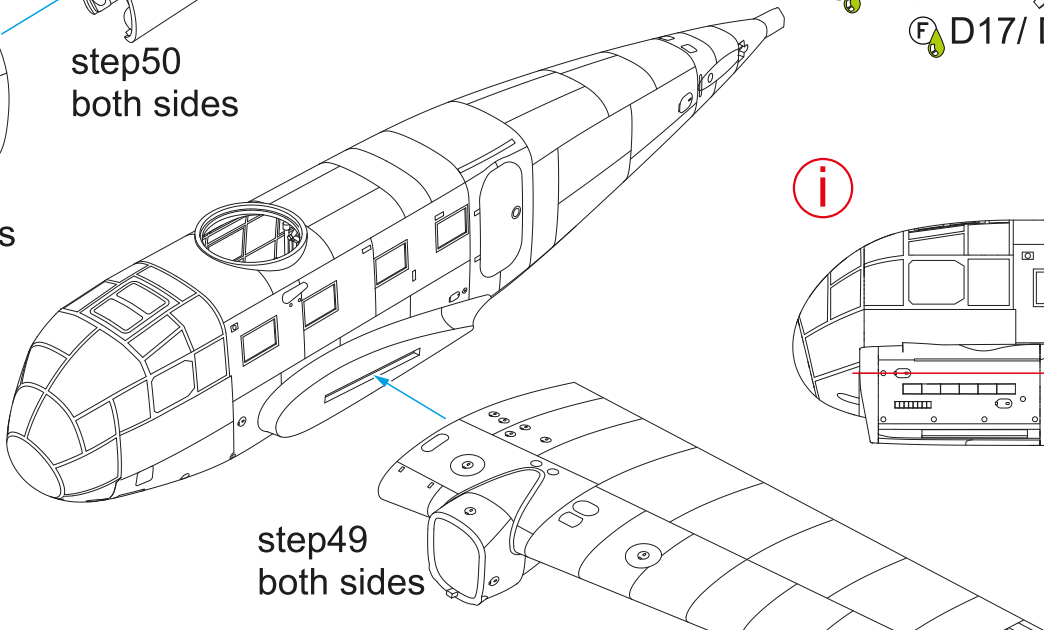

STEP 55

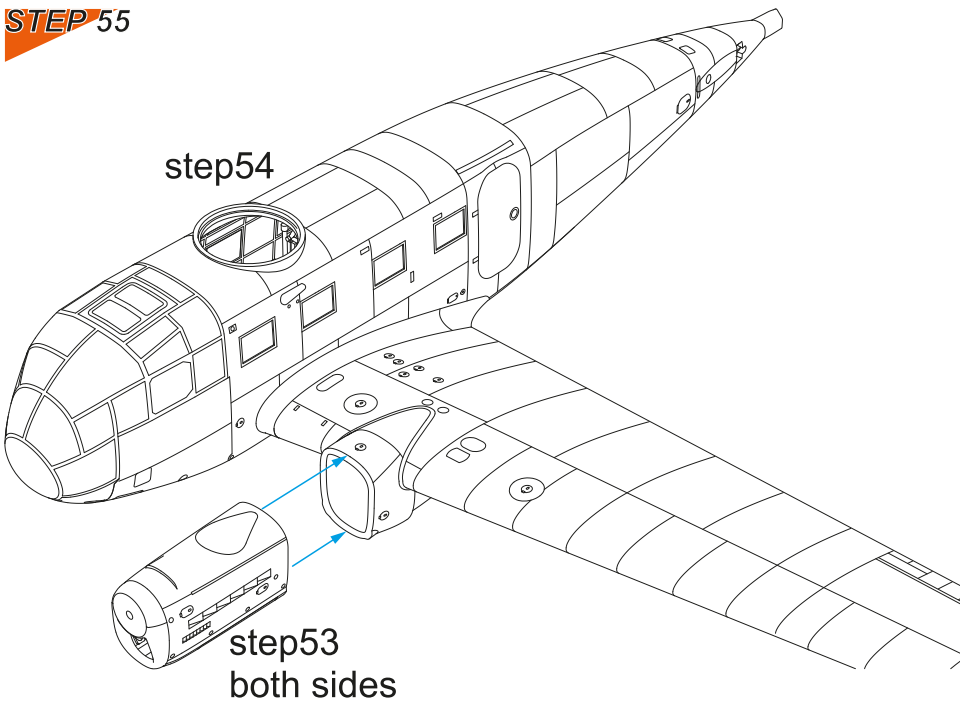

STEP 56

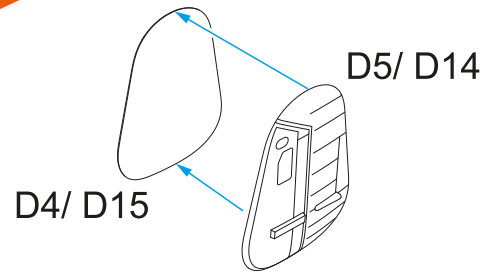

STEP 57

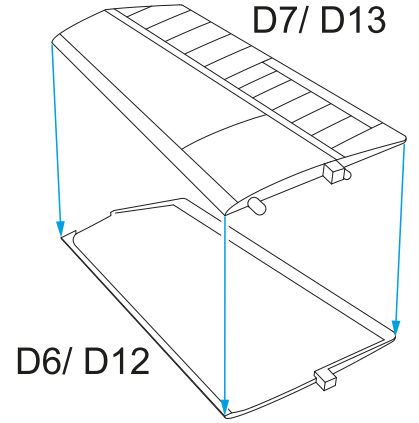

STEP 58

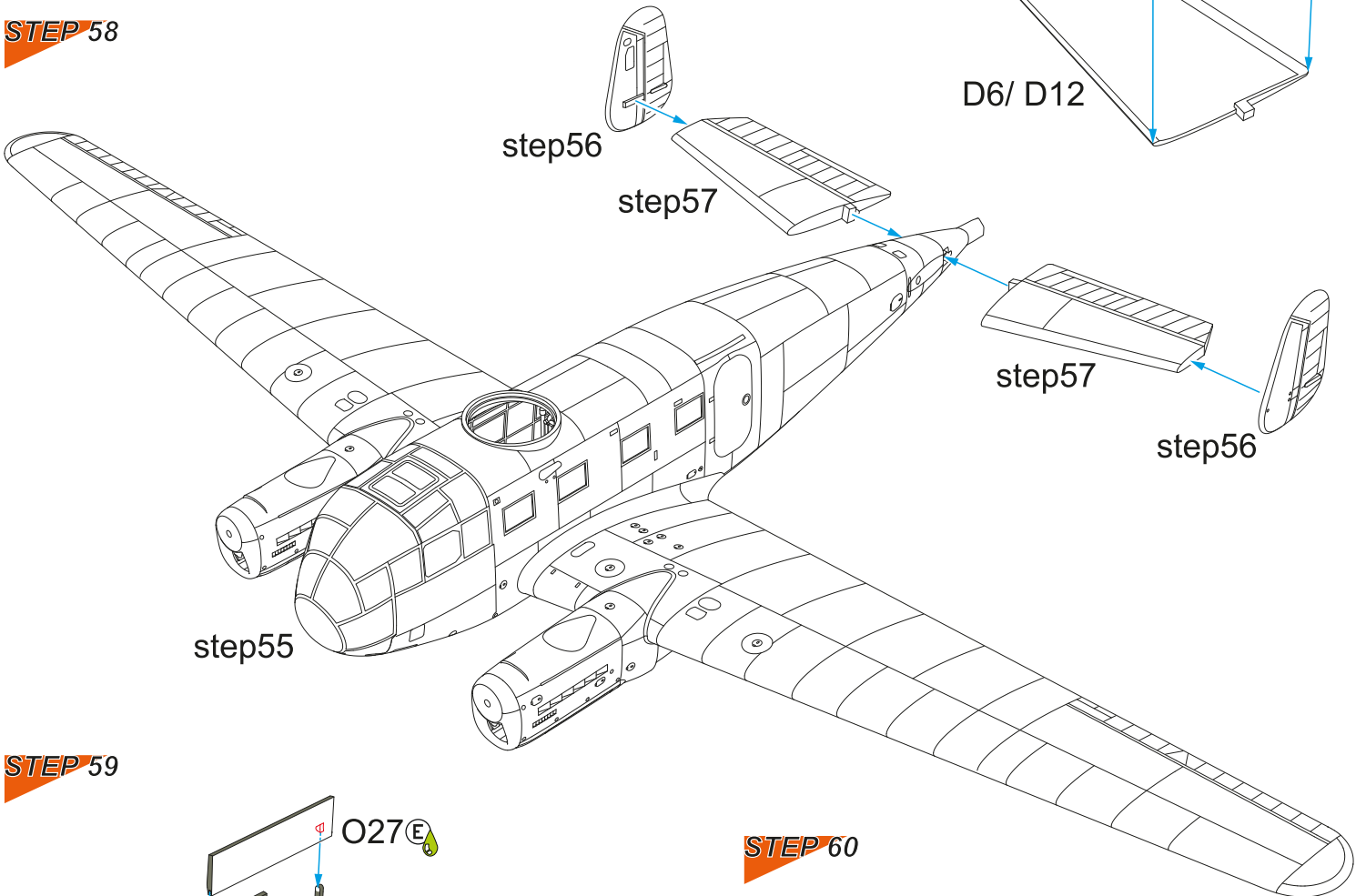

STEP 59

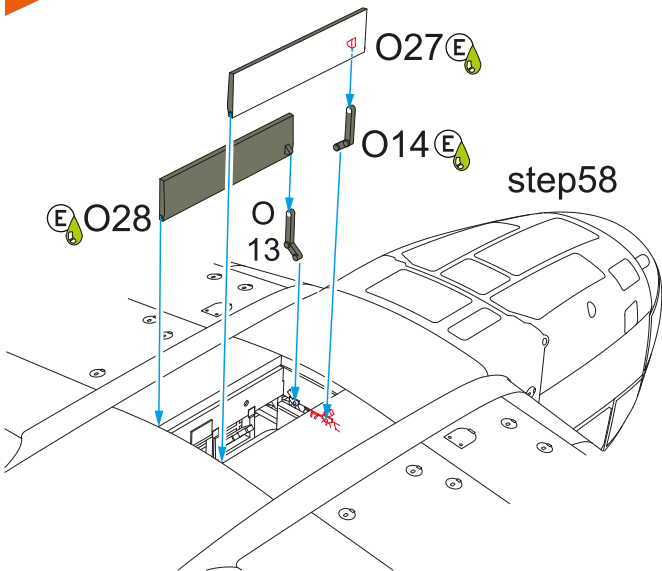

STEP 60

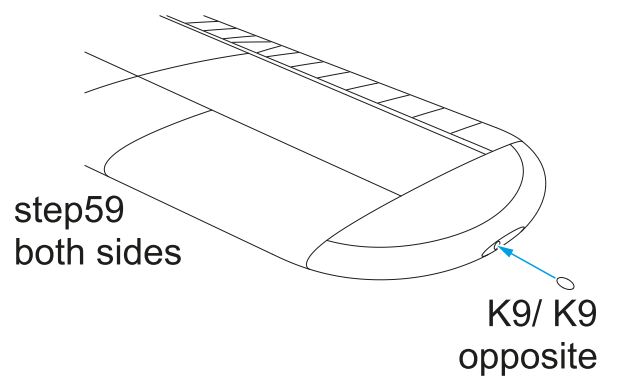

STEP 61

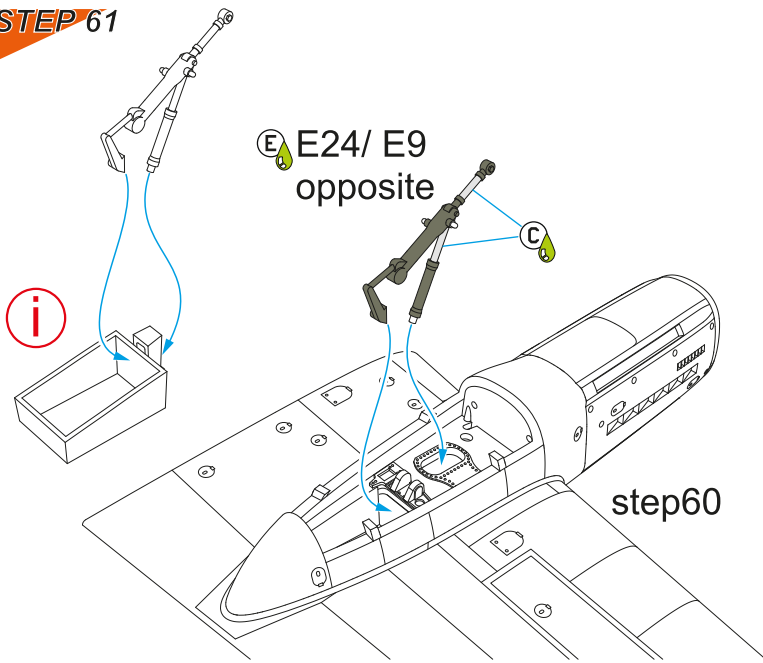

STEP 62

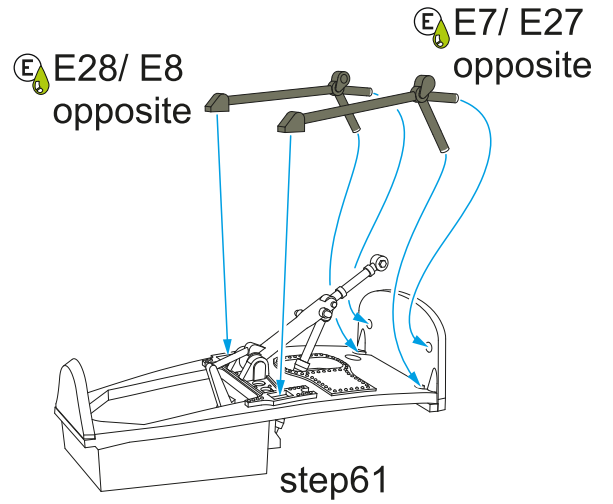

STEP 63

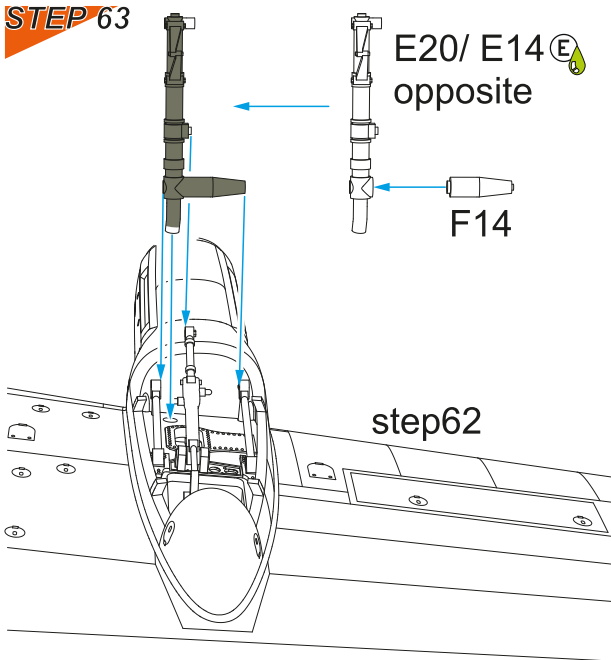

STEP 64

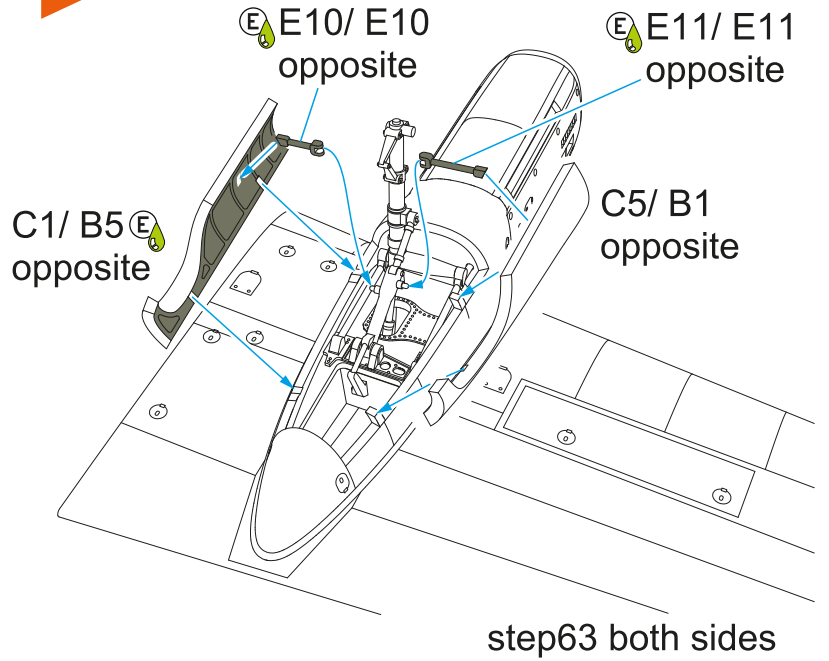

STEP 65

STEP 66

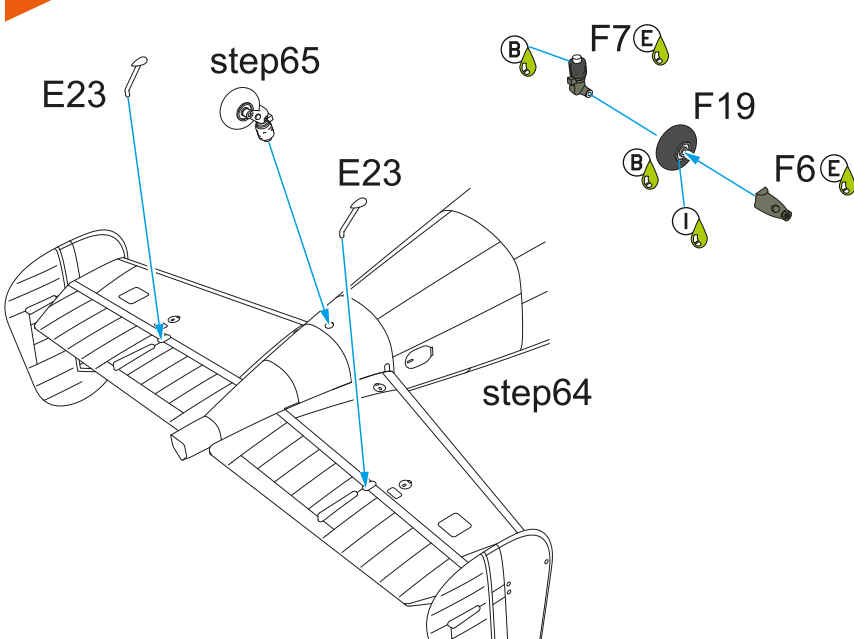

STEP 67

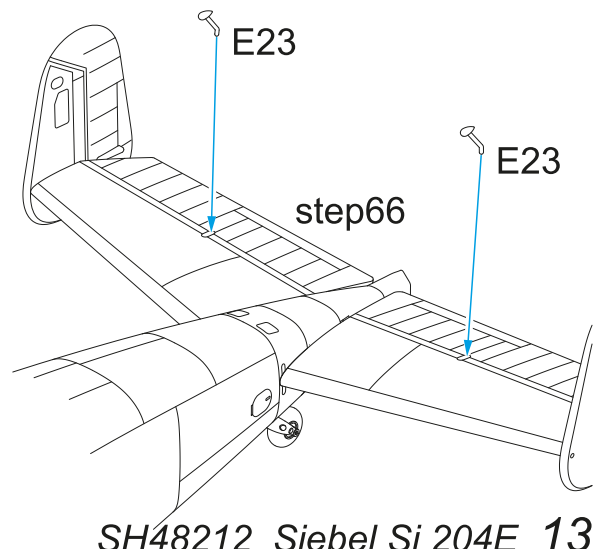

STEP 68

2x

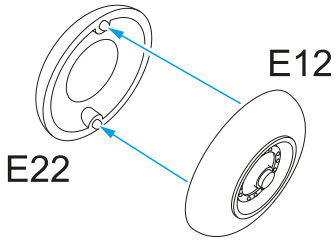

STEP 69

step67

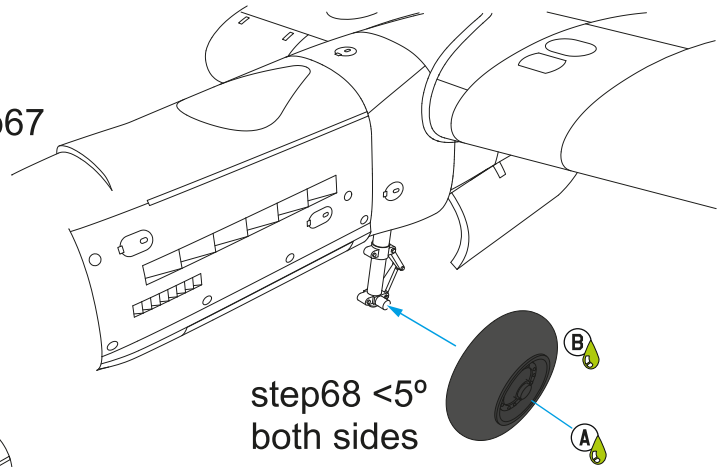

STEP 70

step69
both sides

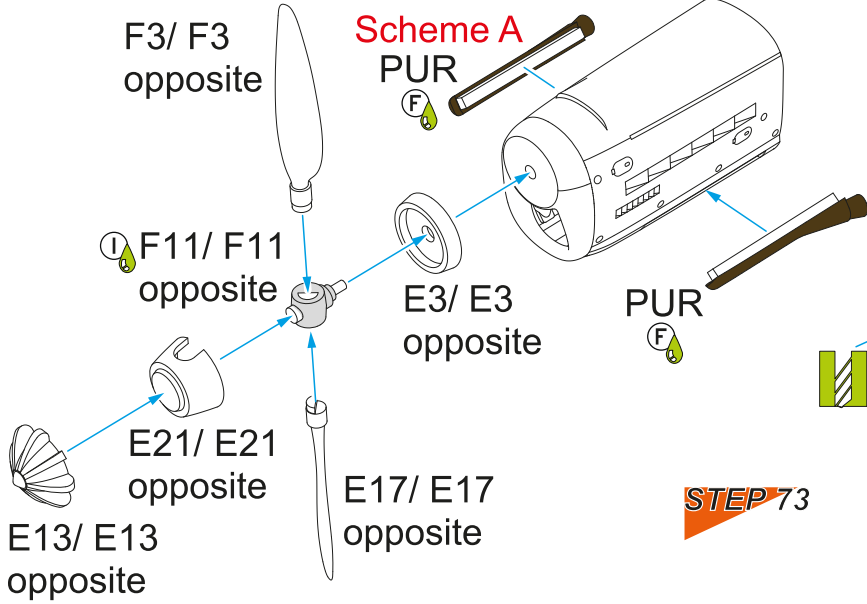

STEP 71

STEP 72

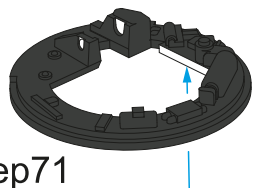
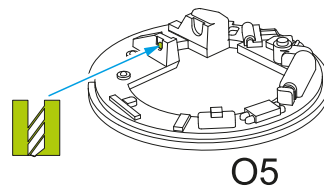

STEP 73

step72

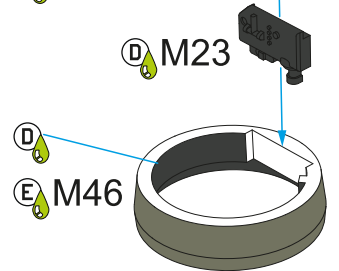

STEP 74

STEP 75

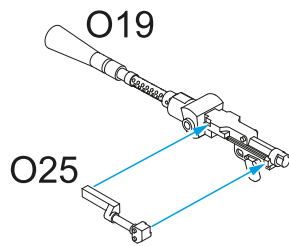
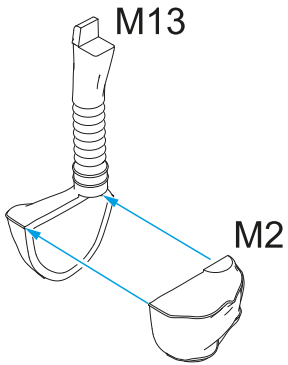

STEP 78

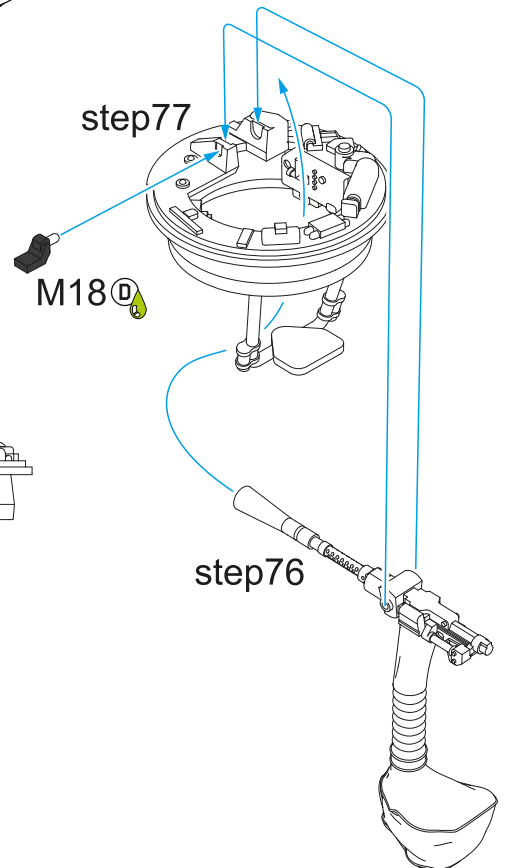

STEP 76

STEP 77

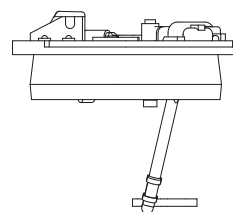
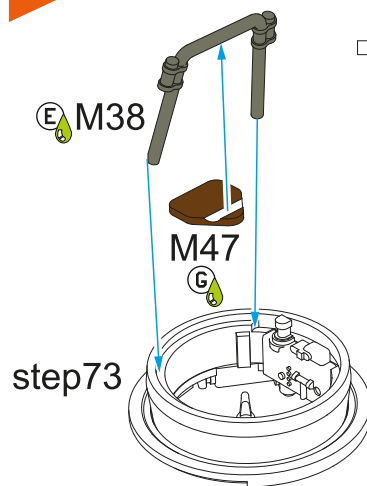
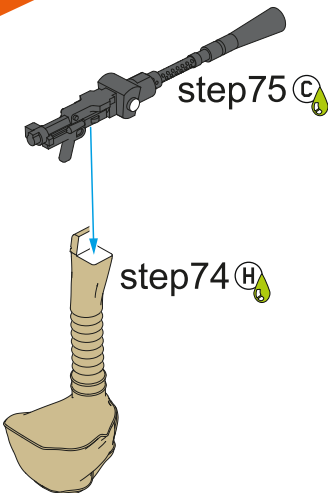

STEP 79

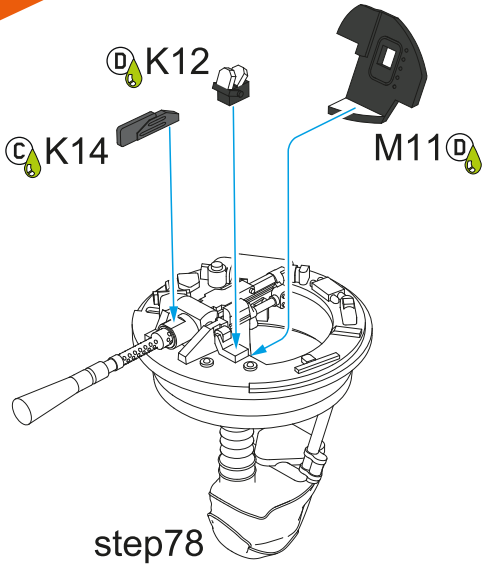

STEP 80

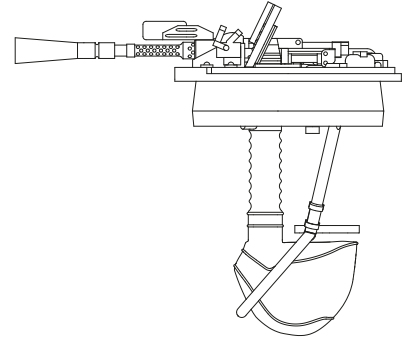
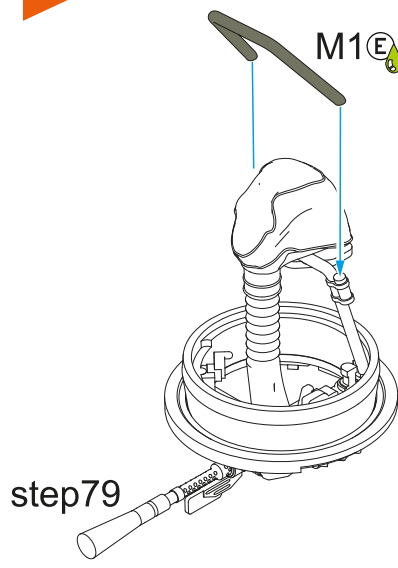

STEP 81

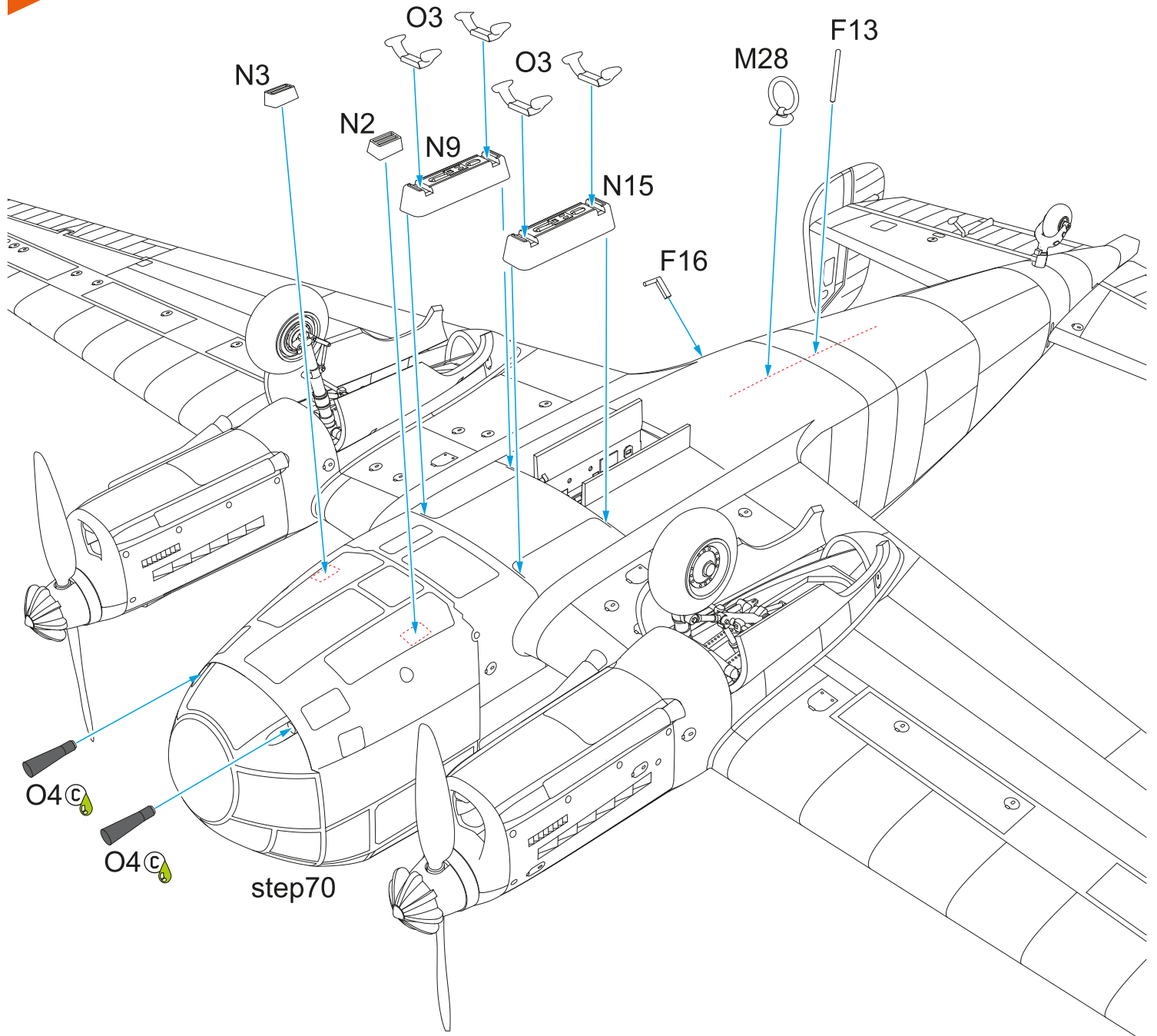

STEP 82

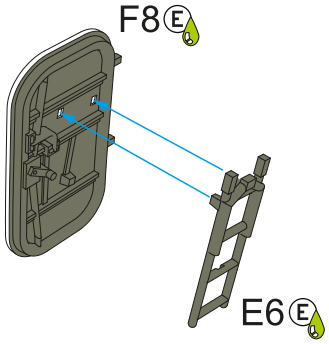

STEP 83

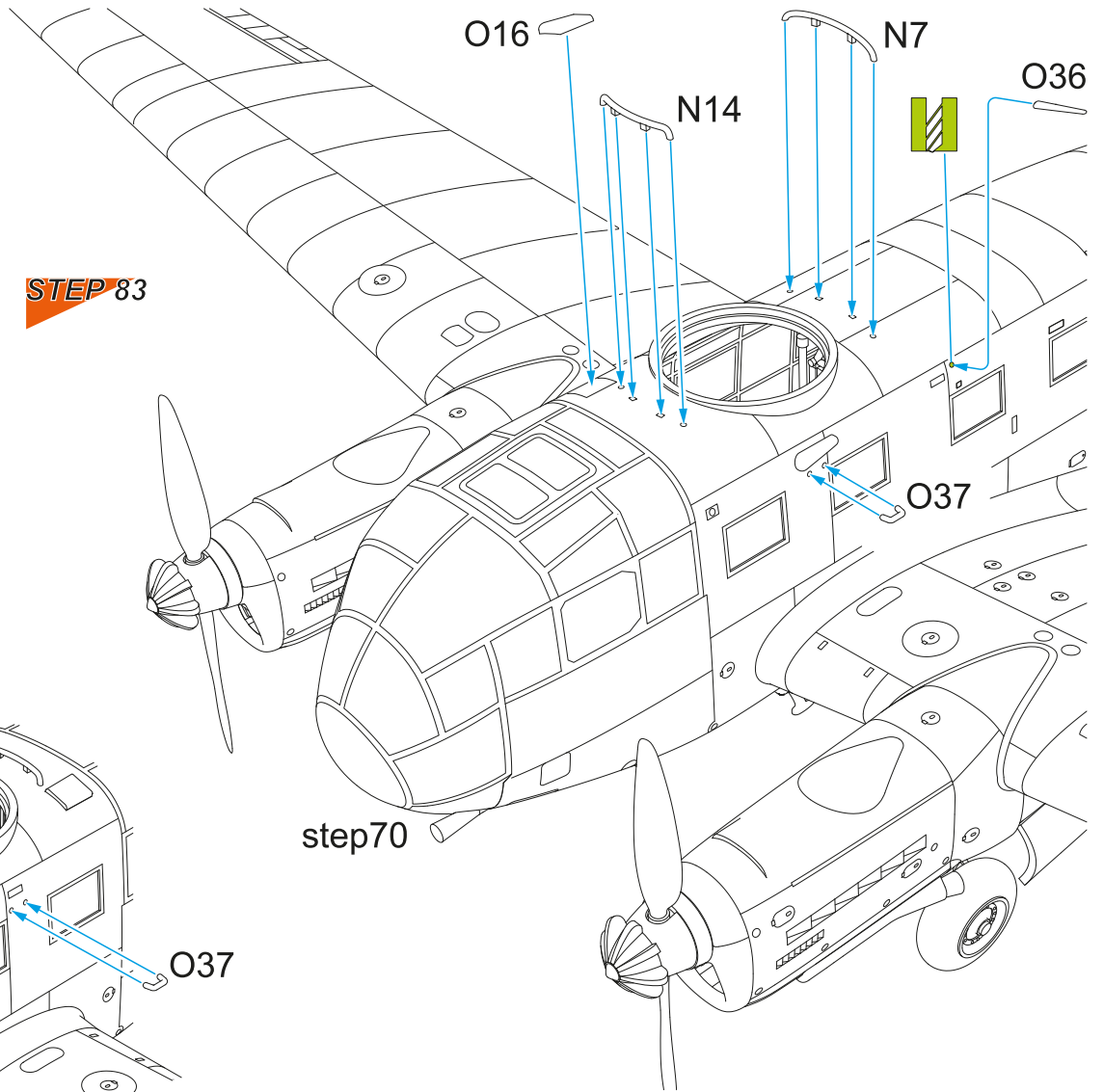

STEP 84

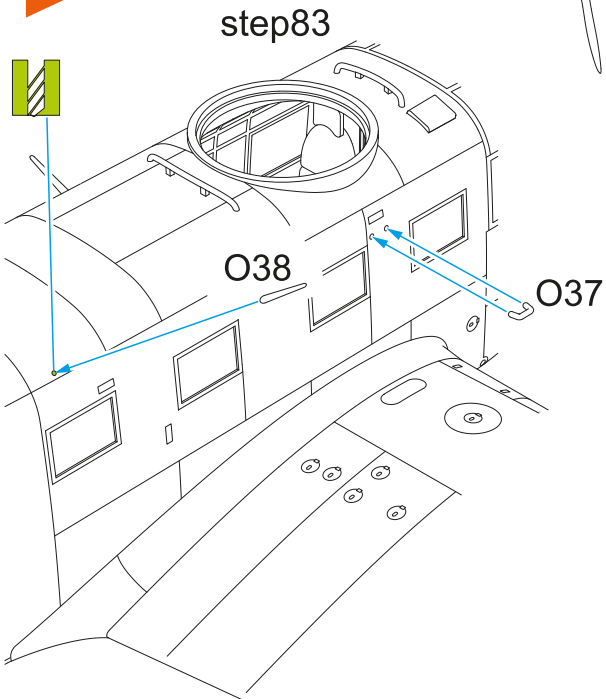

STEP 85

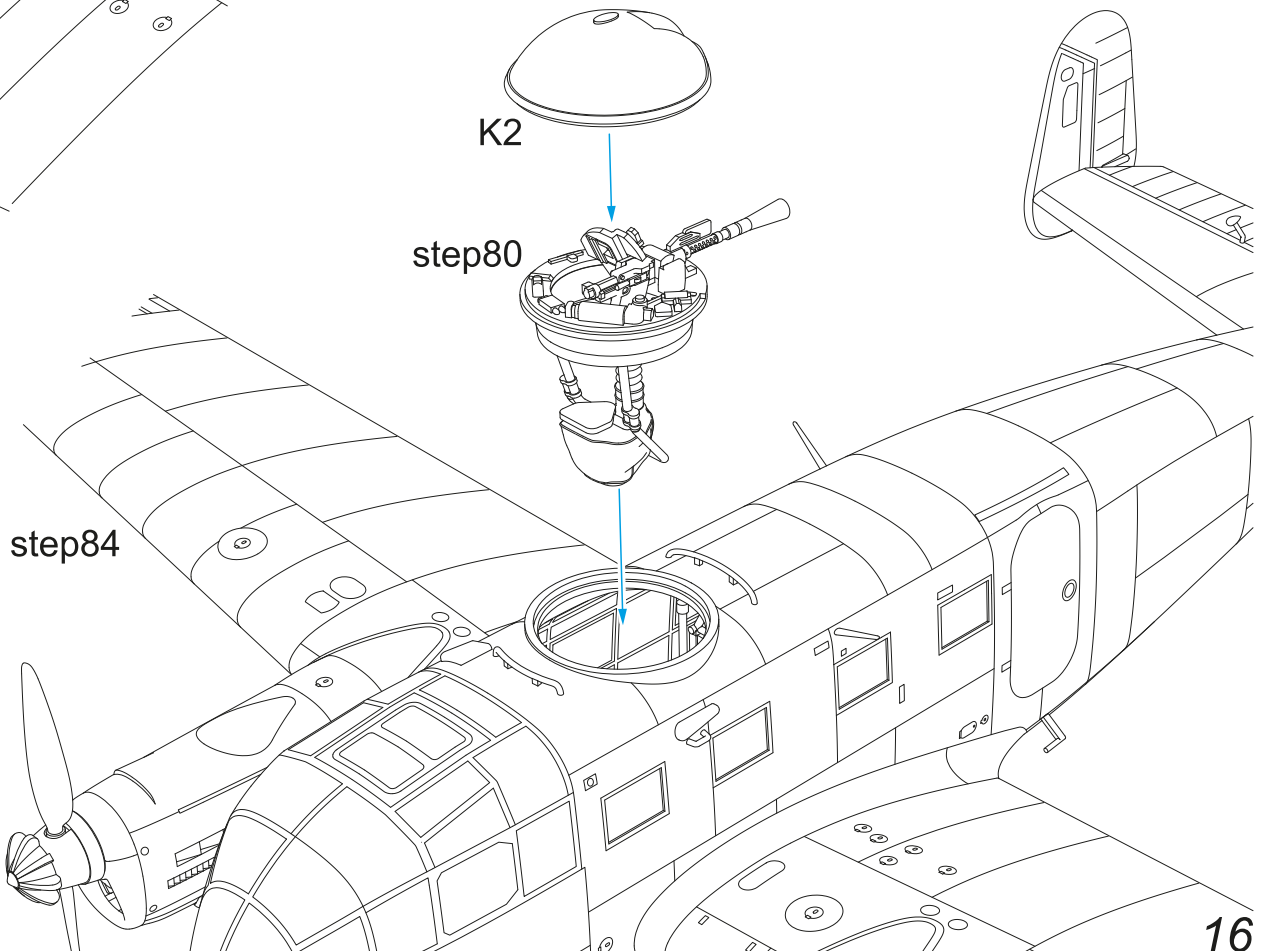

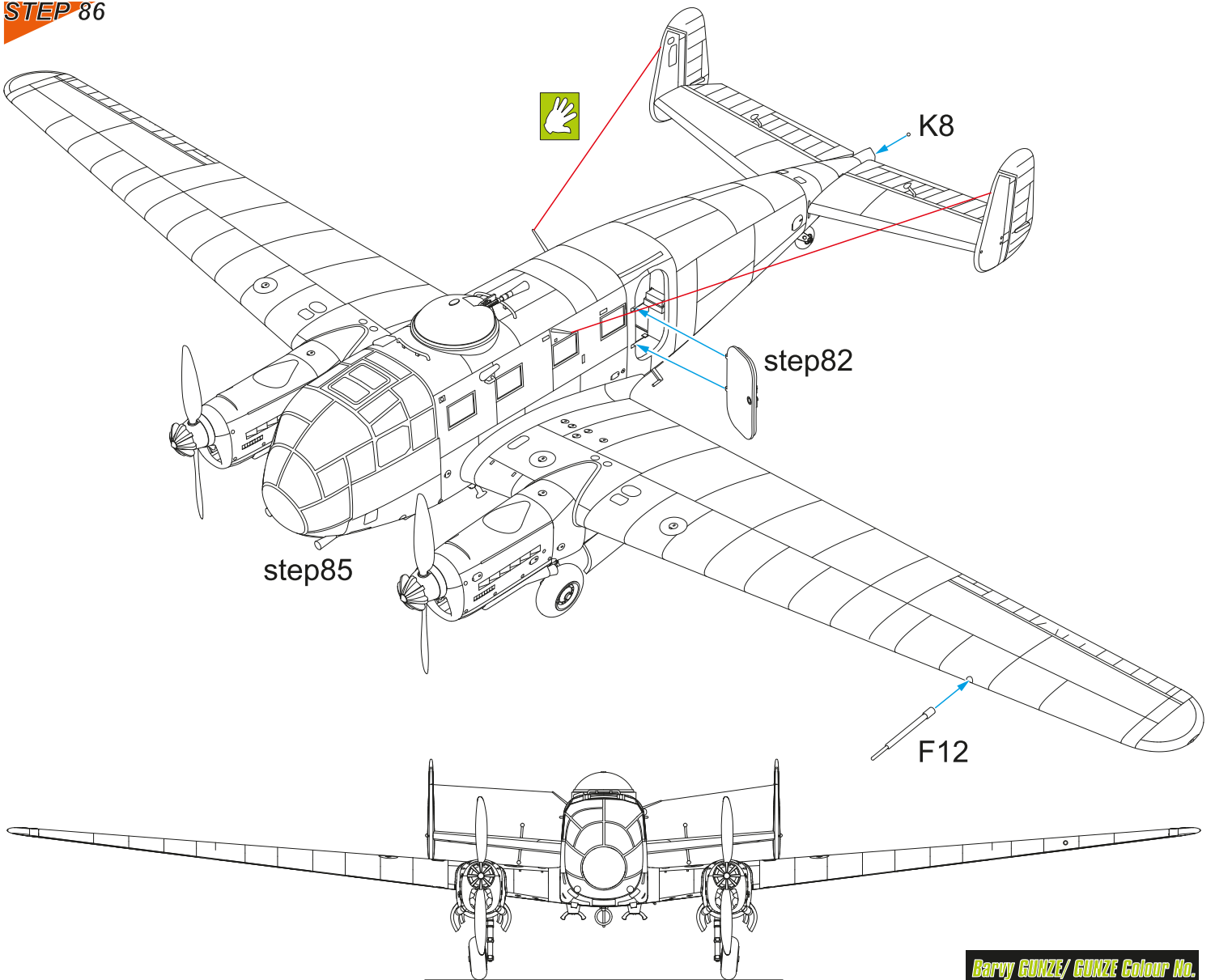

Barvy GUNZE/ GUNZE Colour No.

A Černá/ Black	H12/ C33	E Šedá 02/ Grey 02	H70/ C60	I Hliníková/ Aluminium	H8/ C8
B Barva pneu/ Tire Black	H77/ C137	F Opálený kov/ Burnt Iron	H76/ C61	J Mosaz/ Brass	MC219
C Tmavý kov/ Gun Metal	H28/ C78	G Barva kůže/ Leather	H17/ C29	K Tm. zelená 71/ D. Green 71	H64/ C17
D Černošedá 66/ Black Grey 66	C116	H Pískově žlutá/ Sand Yellow	H66/ C119	L Červená/ Red	H3/ C3

SYMBOLS

MOŽNOST VOLBY OPTIONAL NACH BELIEBEN OPTION	POUŽIT KYANOAKRYLÁTOVÉ LEPIDLO INSTANT CYANOACRYLATE GLUE ZYANOAKRYLÁTKLEBER COLLE CYANOACRYLAT	OHNOUT BEND BIEGEN COURBER	ZHOTOVIT NOVÉ SCRATCH BUILD FERTIGSTELLEN ACHEVER	ŘEZAT/VRTAT CUT OFF/DRILL ENTFERNEN DETACHER	GSI colour code	NATŘÍT COLOUR FARBEN PEINDRE
--	--	-------------------------------------	--	---	--------------------	---------------------------------------

1/48 CMK sets for Siebel Si 204/Aero C-3

 F48357 Mechanic (Engine Repair)	 F48358 Airman (Cleaning Canopy Glazing)	 F48359 Rigger (Prop Maintenance)	 F48367 Luftwaffe WW2 / CS Post-War Aircraft Mechanic	 Q48352 Wheels	 Q48353 Pilots' Seats	 4386 Engine
				 Q48354 Prop Spinners	 4415 German WWII Aircraft Maintenance Toolbox	

Siebel Si 204E-0, 1K+BA, Stab./NSGr.4, Balice airfield (now John Paul II International Airport Krakow-Balice), occupied Poland, Autumn 1944. The machine probably took part in the suppression of the Slovak National Uprising.

Siebel Si 204E-0, 1K+BA, Stab./NSGr.4, letiště Balice (nyní Mezinárodní letiště Jana Pavla II. Krakov-Balice), okupované Polsko, podzim 1944. Letoun se pravděpodobně zúčastnil potlačování Slovenského národného povstání.

Camo A

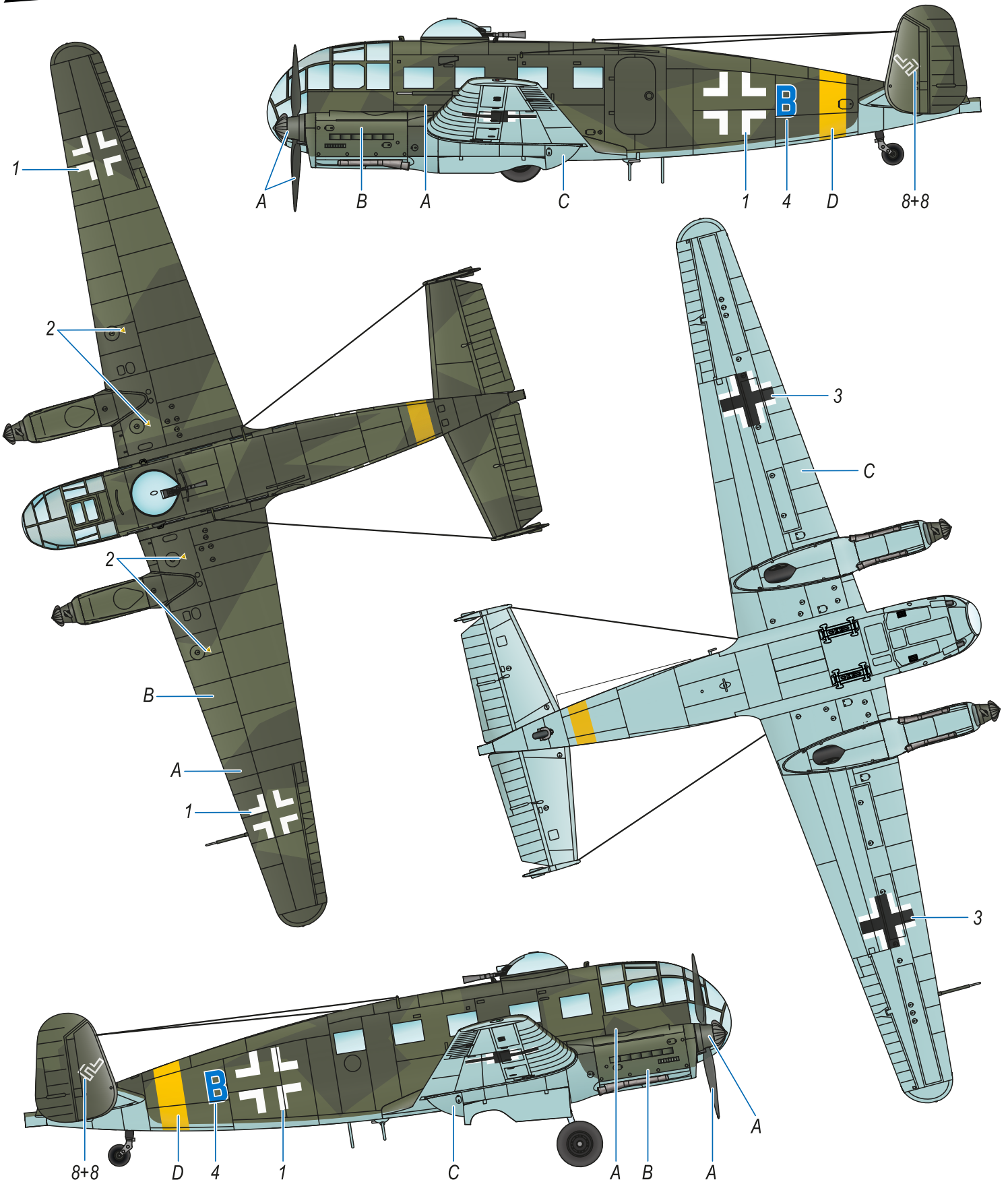





- | | | | |
|---|--|---|---|
| <p>A Black Green
Schwarzgrün
Černozelená
H65/C18/RLM70</p> | <p>B Dark Green
Dunkelgrün
Tmavě zelená
H64/C17/RLM71</p> | <p>C Light Blue
Hellblau
Světle modrá
H67/C115/RLM65</p> | <p>D Yellow
Gelb
Žlutá
H413/C113/RLM04</p> |
|---|--|---|---|

Siebel Si 204E-0, 1K+AL, Stab./NSGr.4, Balice airfield (now John Paul II International Airport Krakow-Balice), occupied Poland, Autumn 1944. This machine also probably took part in actions against the Slovak National Uprising. On 23 December 1944 while taking off from Balice, the port side engine stopped working and the machine crashed into the ground, killing its entire crew of Oblt. P. Bäuerle (pilot), Ofw. G. Spatholz (observer), Fw. J. Eberl (radio operator) and Ogefr. M. Schmucker (mechanic).

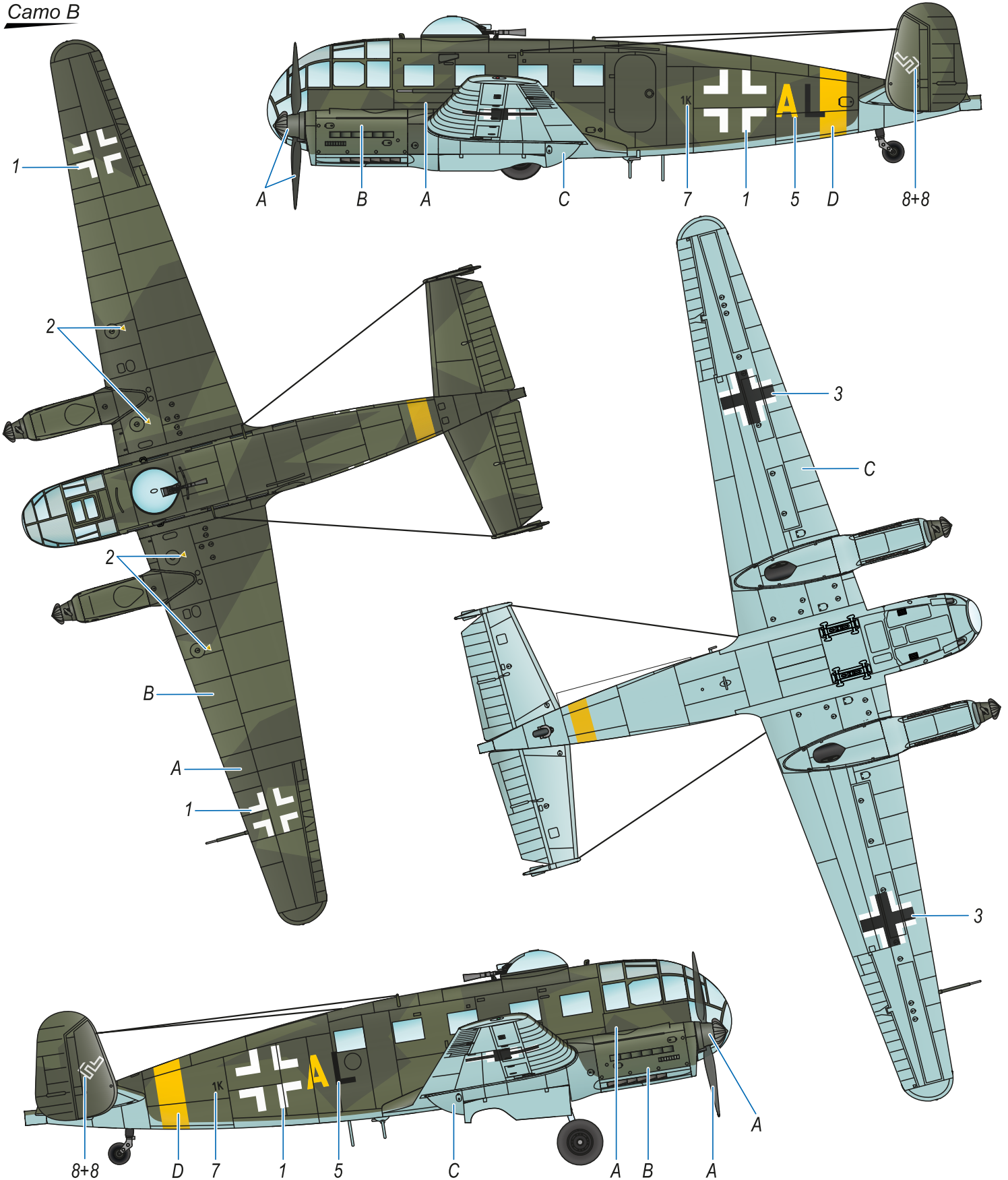
Siebel Si 204E-0, 1K+AL, Stab./NSGr.4, letiště Balice (nyní Mezinárodní letiště Jana Pavla II. Krakov-Balice), okupované Polsko, podzim 1944. Letoun se pravděpodobně zúčastnil potlačování Slovenského národného povstání. 23. 12. 1944 při vzletu z Balice došlo k zastavení levého motoru. Letoun se zřítil a osádka Oblt. P. Bäuerle (pilot), Ofw. G. Spatholz (pozorovatel), Fw. J. Eberl (radista) a Ogefr. M. Schmucker (mechanik) zahynula.

Camo B



- | | | | | | | | |
|--|---|---|--|---|---|---|---|
|  | A Black Green
Schwarzgrün
Černozelená
H65/C18/RLM70 |  | B Dark Green
Dunkelgrün
Tmavě zelená
H64/C17/RLM71 |  | C Light Blue
Hellblau
Světle modrá
H67/C115/RLM65 |  | D Yellow
Gelb
Žlutá
H413/C113/RLM04 |
|--|---|---|--|---|---|---|---|

Siebel Si 204E-0 V-22, Red D, possibly the bomber version prototype built from a Si 204D.

Siebel Si 204E-0 V-22, červené D, pravděpodobně prototyp bombardovací verze, přestavěný ze Siebelu Si 204D.

Camo C

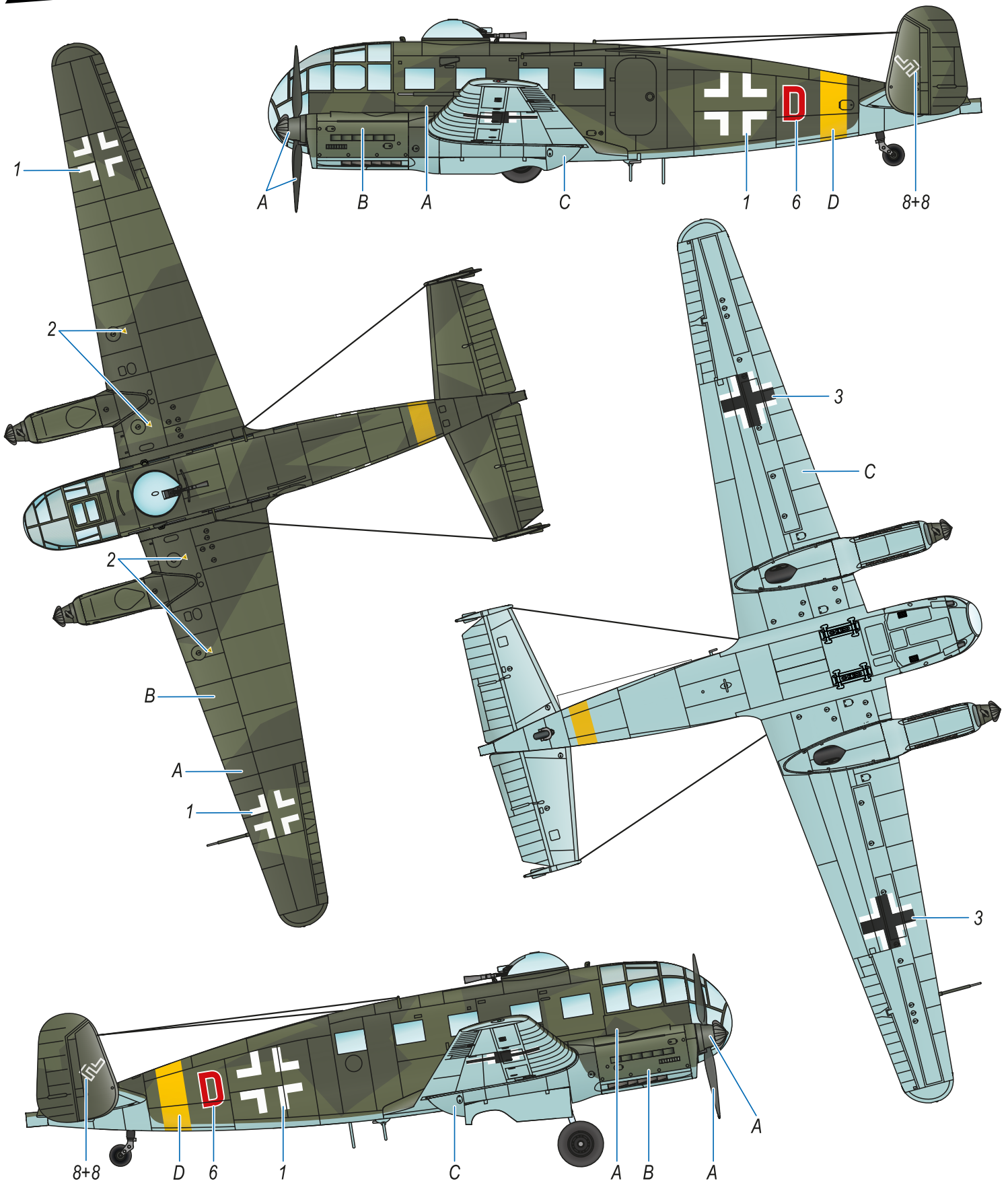

- | | | | |
|---|--|---|---|
| <p>A Black Green
Schwarzgrün
Černozelená
H65/C18/RLM70</p> | <p>B Dark Green
Dunkelgrün
Tmavě zelená
H64/C17/RLM71</p> | <p>C Light Blue
Hellblau
Světle modrá
H67/C115/RLM65</p> | <p>D Yellow
Gelb
Žlutá
H413/C113/RLM04</p> |
|---|--|---|---|