

BRÜCKENKRAN

GANTRY CRANE

GRUE DE PONT

BRUGKRAAN



Art. Nr. 120163

D

Machen Sie sich bitte vor Beginn des Bastelns mit dem Bausatzinhalt und der Anleitung vertraut und prüfen Sie die Vollständigkeit. Im Reklamationsfall gilt die gesetzliche Gewährleistungspflicht. Sollte ein Teil fehlen, übersenden Sie bitte den Teilwunsch und den Kaufbeleg an: Gebr. FALLER GmbH, Kundendienst, Kreuzstraße 9, D-78148 Gütenbach, kundendienst@faller.de. Sollten Sie einmal weitere Ersatzteile benötigen, senden wir Ihnen den benötigten Spritzling, bei Verfügbarkeit, gerne kostenpflichtig zu. Bitte beachten Sie, dass produktionsbedingt Einzelteile übrig bleiben können.

GB

Before building your model, please familiarize yourself with the contents of the kit and the instructions for use, also checking whether the set of parts is complete. In case of any complaint, the legal guarantee obligation shall apply. Should a part be missing, please send the designation of the part required and the receipt documenting your purchase to: Gebr. FALLER GmbH, Kundendienst, Kreuzstraße 9, D-78148 Gütenbach, kundendienst@faller.de. Should you require further spare parts one day, we shall be pleased to send you, with costs, the required sprue, if it is available. Please note that, on grounds of the production process, some single injection molded parts may be superfluous.

F

Avant de commencer votre modèle, veuillez vous familiariser avec le contenu du kit et la notice d'emploi, et contrôlez que le lot de pièces est complet. En cas de réclamation, il s'appliquera l'obligation de garantie légale. Au cas où une pièce manquerait, veuillez envoyer la désignation de la pièce souhaitée et le bon d'achat à: Gebr. FALLER GmbH, Kundendienst, Kreuzstraße 9, D-78148 Gütenbach, kundendienst@faller.de. Au cas où vous auriez besoin un jour d'autres pièces détachées, nous vous enverrons volontiers la grappe requise, si elle est disponible, contre paiement. Veuillez noter que, pour des raisons de production, il se peut que des pièces détachées soient superflues.

NL

Maak uzelf vóór het bouwen vertrouwd met de inhoud van het bouwpakket en met de handleiding en controleer de volledigheid. In geval van reclamatie geldt de wettelijke garantieverplichting. Mocht er een onderdeel ontbreken, stuur het verzoek om het gewenste onderdeel en het aankoopbewijs dan naar: Gebr. FALLER GmbH, klantenservice, Kreuzstraße 9, D-78148 Gütenbach, kundendienst@faller.de. Als u ooit meer reserveonderdelen nodig hebt, sturen wij het benodigde gietstuk, indien beschikbaar, graag tegen betaling naar u op. Let op: om productieredenen kunnen losse onderdelen overblijven.

Für den Zusammenbau des Modells empfehlen wir folgende FALLER-Artikel (sind nicht im Bausatz enthalten):
For the assembly of the kit we recommend following FALLER products (not included in the kit):
Pour l'assemblage du modèle, nous vous recommandons les articles FALLER suivants (non inclus dans le kit):
Om dit model te bouwen adviseren wij de volgende FALLER producten (maken geen deel uit van deze bouwset):

Art. Nr. 170490 | 170492 | 170494
FALLER SUPER-EXPERT | EXPERT | LASERCUT



Art. Nr. 170688
SPEZIAL-SEITENSCHNEIDER



Art. Nr. 170687
FALLER-BASTELMESSER

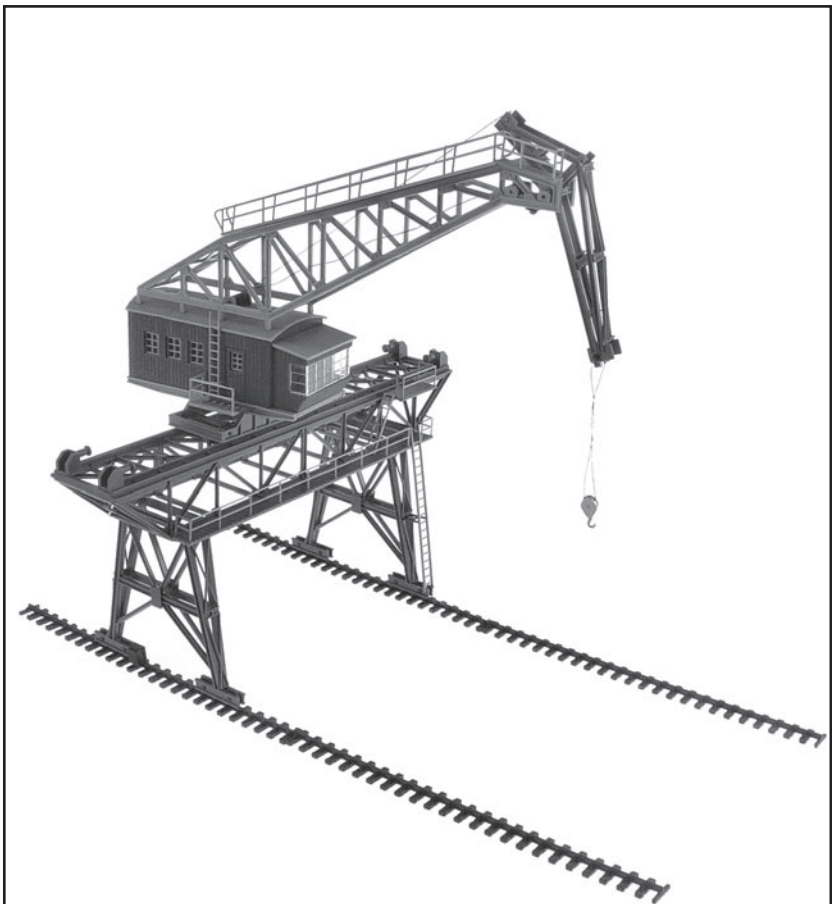

Inhalt	Spritzlinge	1	1 x	4	1 x	11	1 x
Contents	Sprues	2	1 x	5	1 x	13	1 x
Contenu	Moulages	3	1 x	6	1 x	14	1 x
Inhoud	Gietstukken	3	1 x	6	1 x	14	1 x

Sa. Nr. 120 163 1

Vor Beginn des Bastelns sollten Sie sich mit den Variationsmöglichkeiten des Modells vertraut machen (siehe Seite 9).

Before starting the assembly you should familiarize yourselves with the variations of the kit(see page 9).

Avant de commencer l'assemblage, il faut vous familiariser avec les configurations proposées (on pp. 9).

Voor dat u begint met het bouwen adviseren wij u de variatiemogelijkheden van dit bouwmodel te bestuderen (blz. 9).

Variante I



Variante II



Variante III



Variante IV

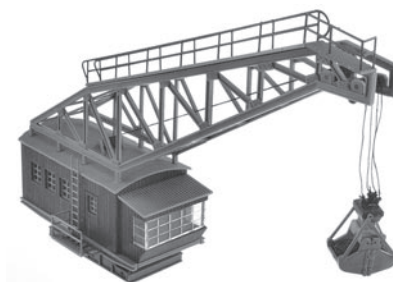

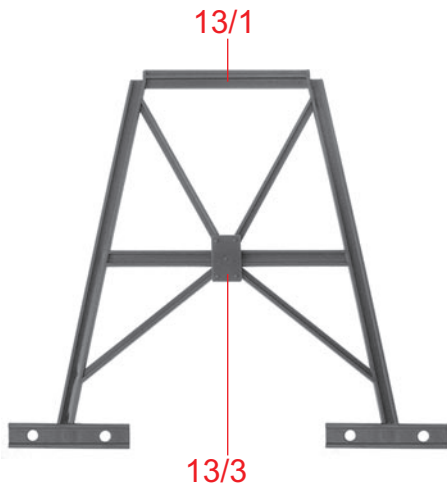

A 4 x



C

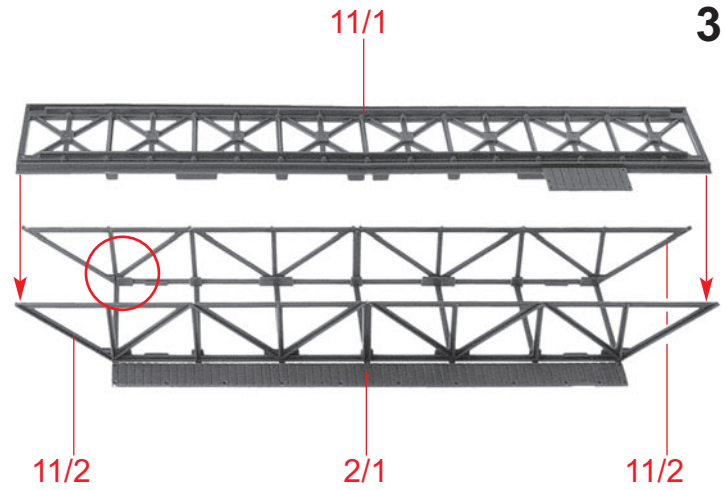

3

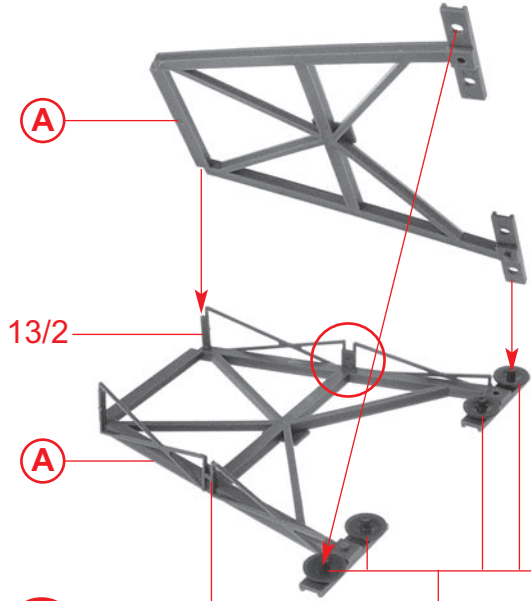

B 2 x 13/2

14/15

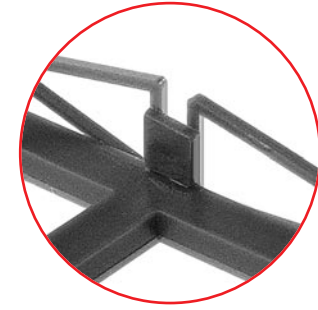

nicht kleben
do not glue
ne pas coller
niet lijmen

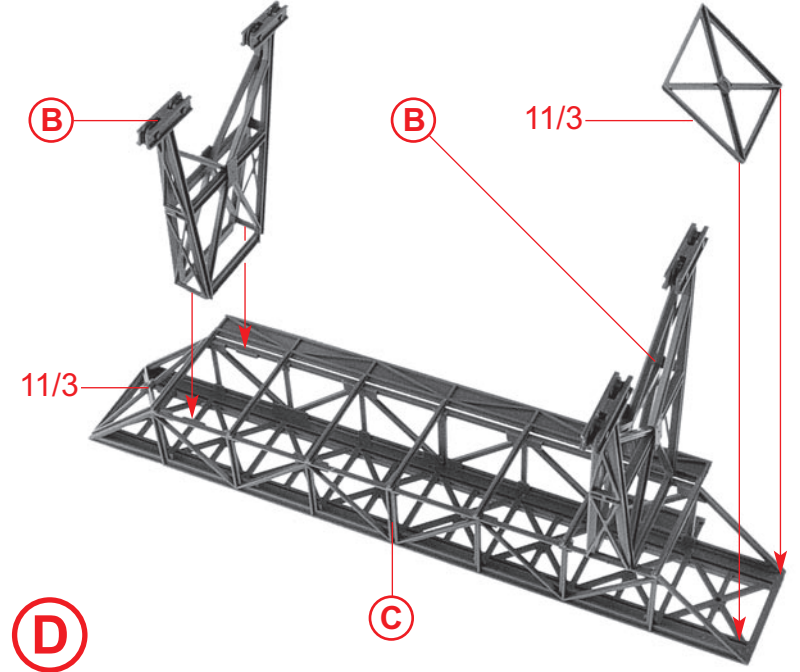

D

C

4

11/4

14/9

14/8

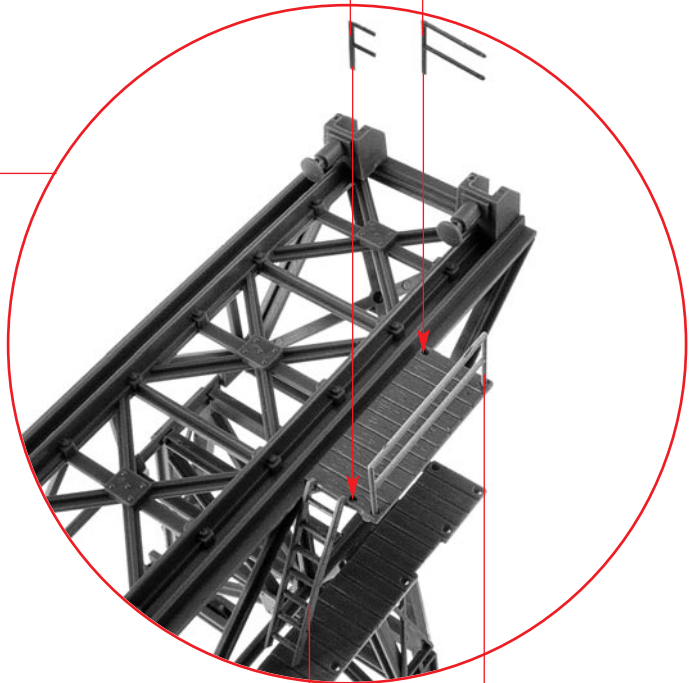
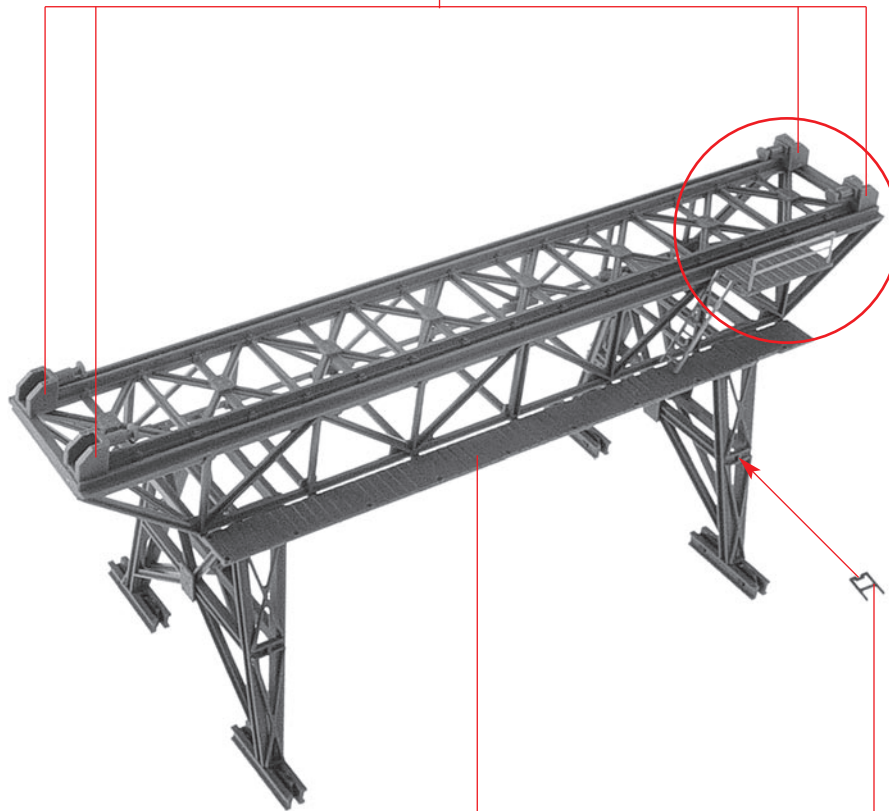

E

D

14/2

14/6

14/7

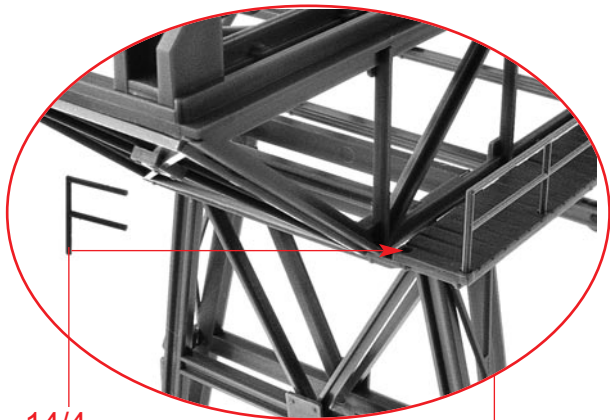

14/4

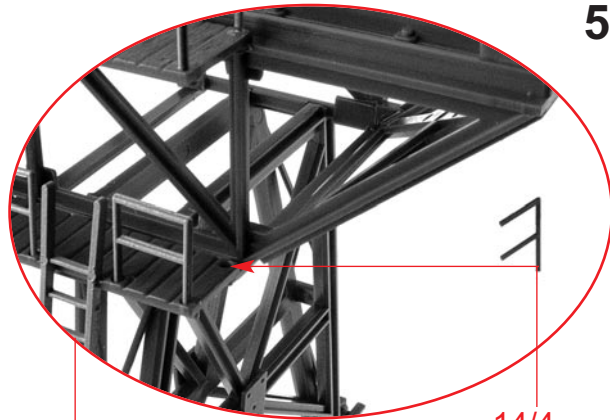

14/4

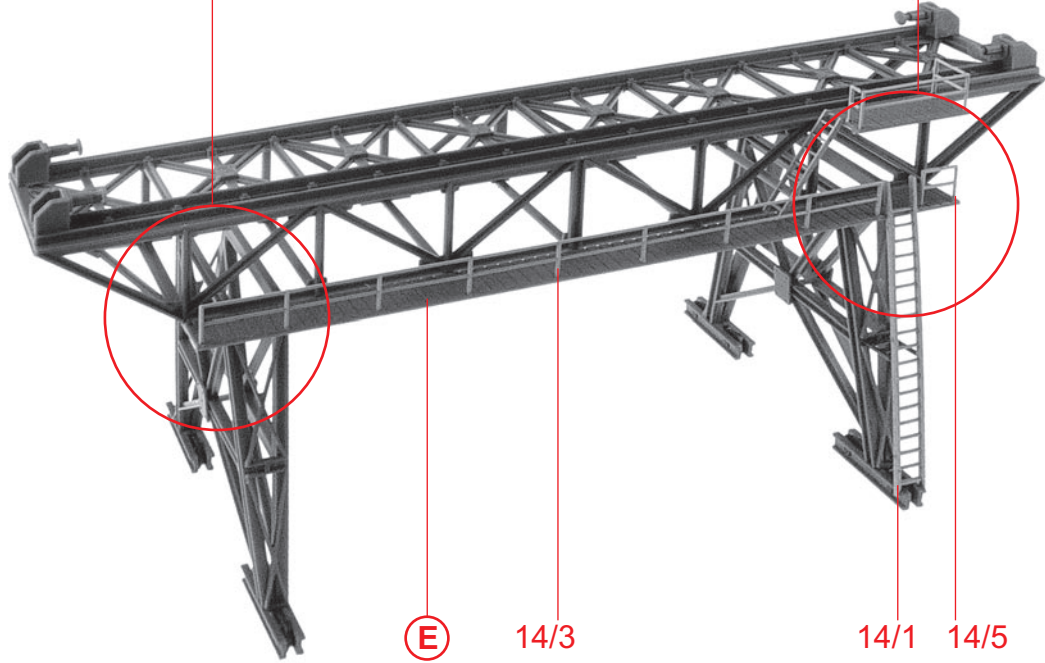

F

E

14/3

14/1

14/5

6

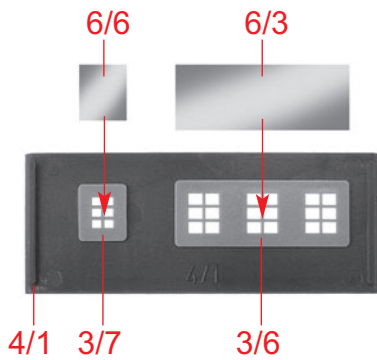

G

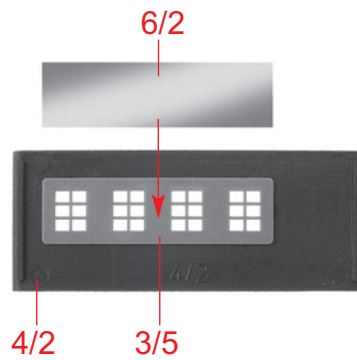

H

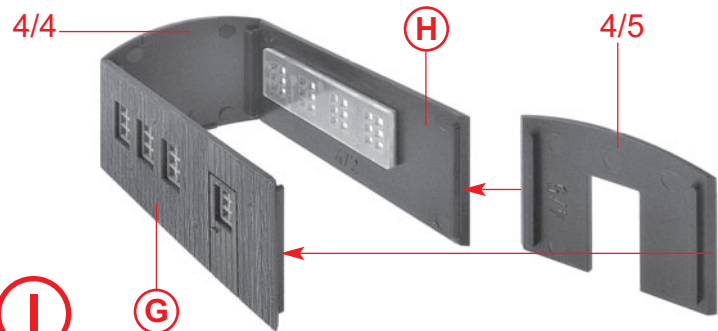

I

G

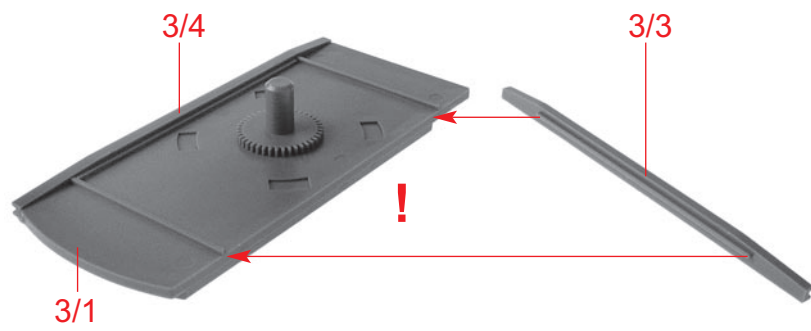

J

3/1

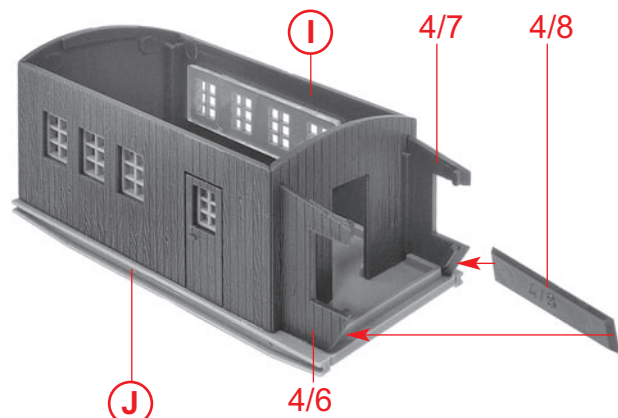

K

J

4/6

L

3/12

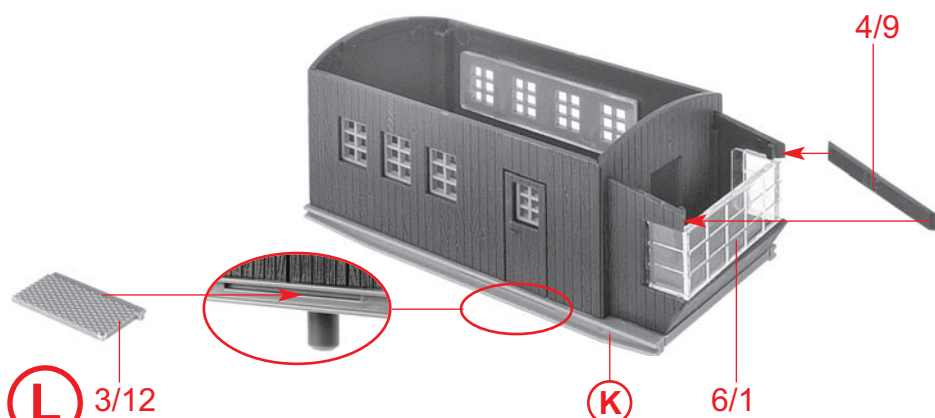

K

6/1

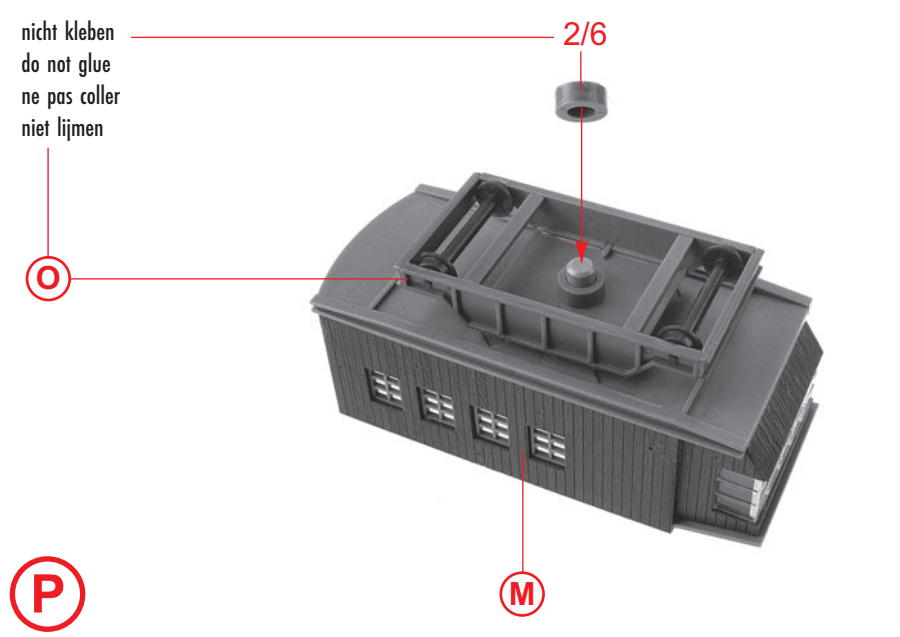
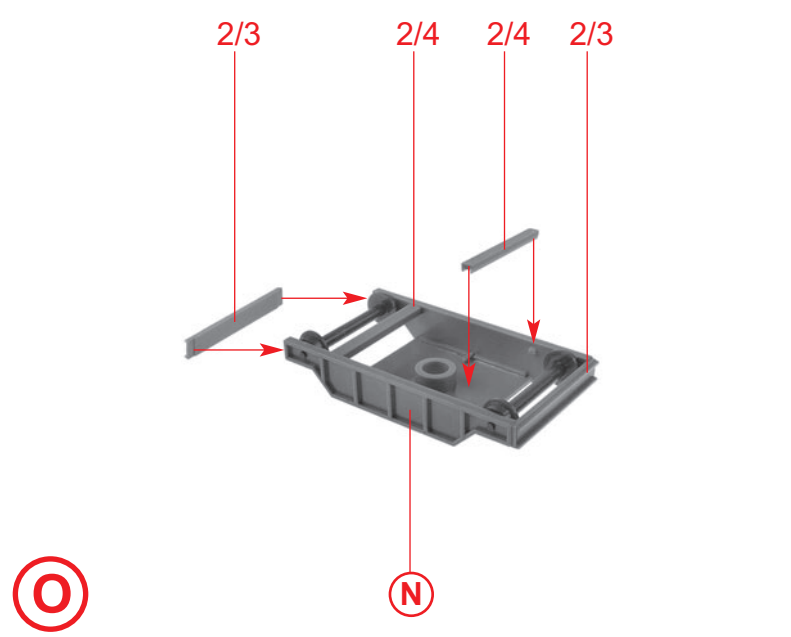
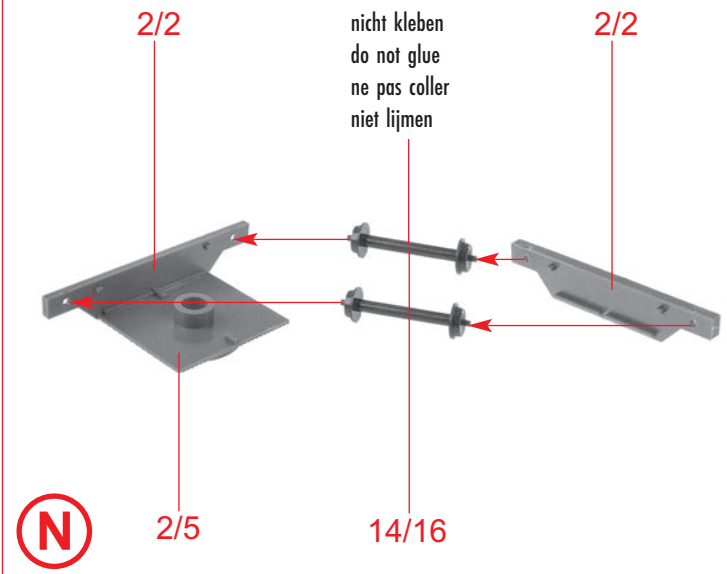
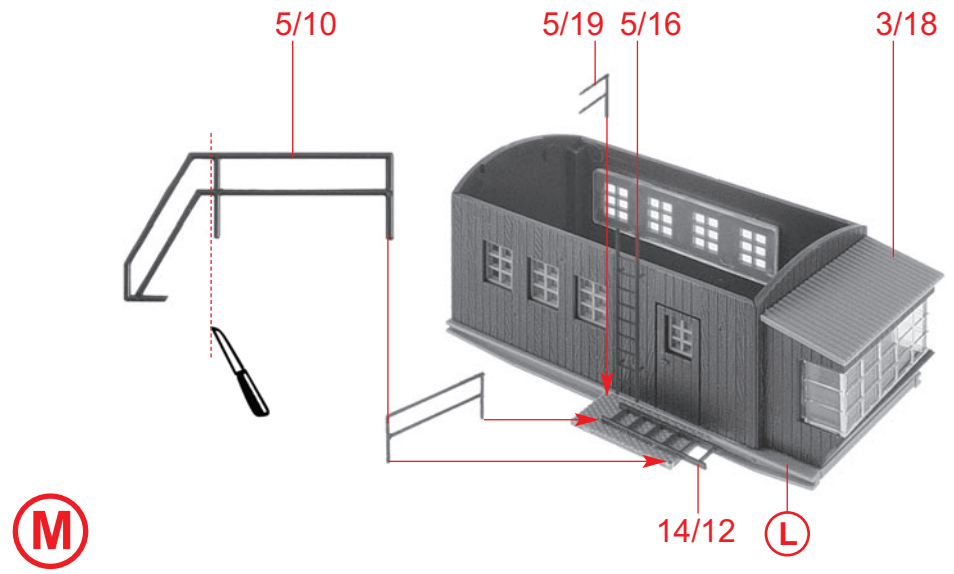

Durch den zusätzlichen Hafenkran-Ausleger erhöht sich das Kippmoment und bei rechtwinkliger Stellung der Brücke kippt der obere Aufbau von der Kranbrücke. Soll der Aufbau auf der Brücke frei verschiebbar sein, muss beim Bauabschnitt Q im hinteren Teil des Führerhauses ein Ballastgewicht (Steinchen, Sand, Blei etc.) gelegt werden. Bekommt der Kran eine feste Position, kann dieser auf die Schiene geklebt werden.

By the addition of the harbour crane jib, then the increased balance when set at right angles to the gantry, can cause the upper part of the crane to tip over. If the gantry be so constructed as to be freely moved along, then during construction of part Q a balance weight (small stones, sand, lead, etc.) should be inserted. If the crane is to be in a fixed position, then it can be glued to the rails.

Si vous désirez conserver sa mobilité à la partie supérieure de la grue, il convient lester l'arrière de l'abrie avec un poids: cailloux, sable, plomb, pour stabiliser l'installation. On aura intérêt à coller la grue au ballast, pour le cas où on ne prévoit pas de la déplacer.

Door de extra kraanarm kiept de bovenbouw vlug om, vooral wanner deze een haakse stand ten opzichte van de kraanbrug heft. Als de bovenbouw over de brug moet kunnen bewegen, moet bij bouwfase Q ballast (steentjes, zand, lood enz.) in het achterste deel van de cabine worden aangebracht. Indien de kraan permanent wordt opgesteld, kan deze op de rails worden gelijmd.

nicht kleben
do not glue
ne pas coller
niet lijmen

P

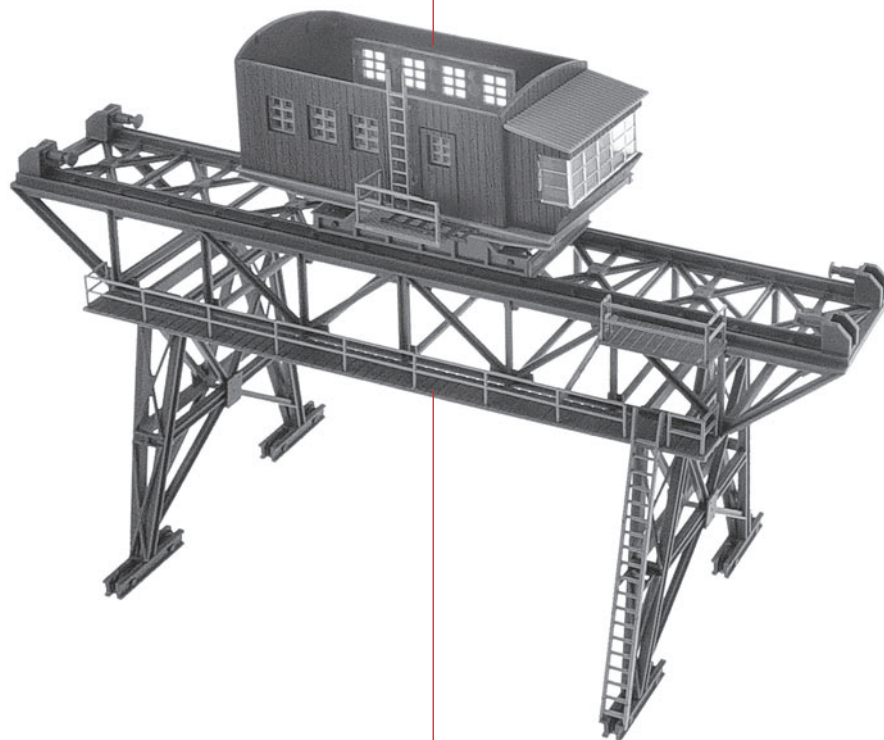

F

Q

R

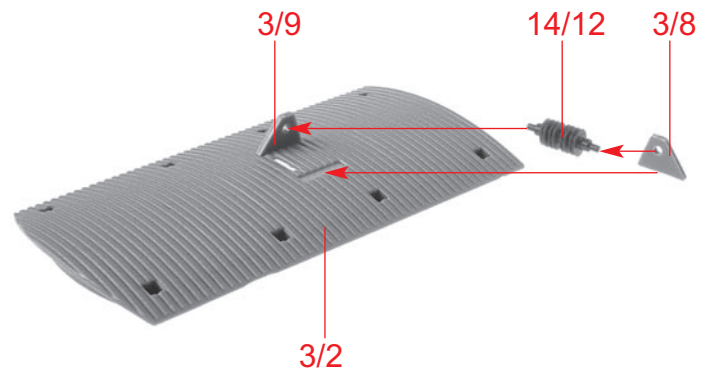

S

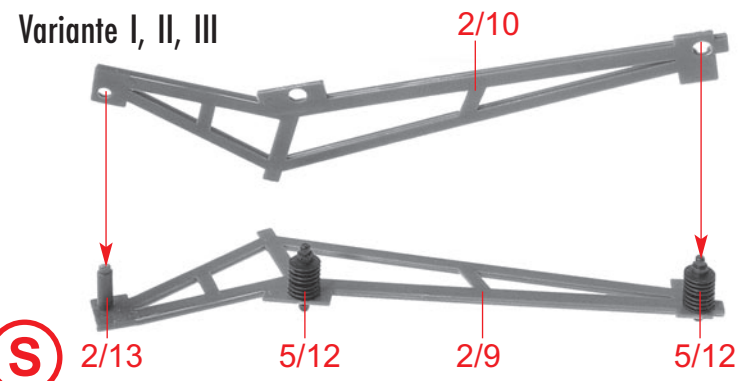

Variante I, II, III

T

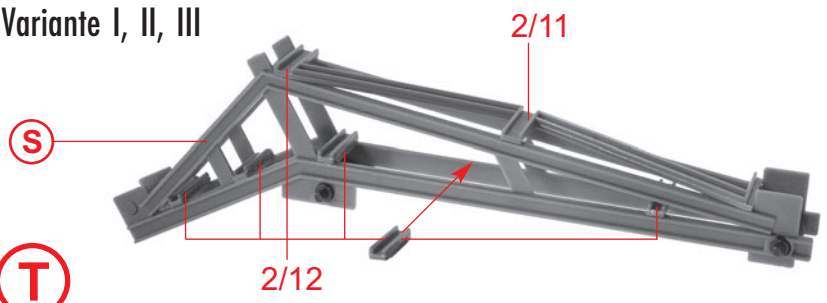

U

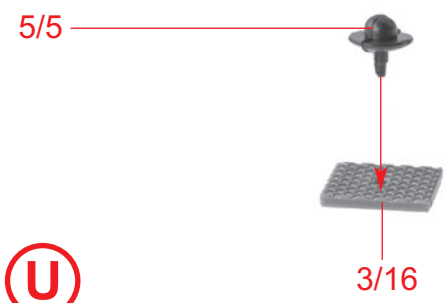

V

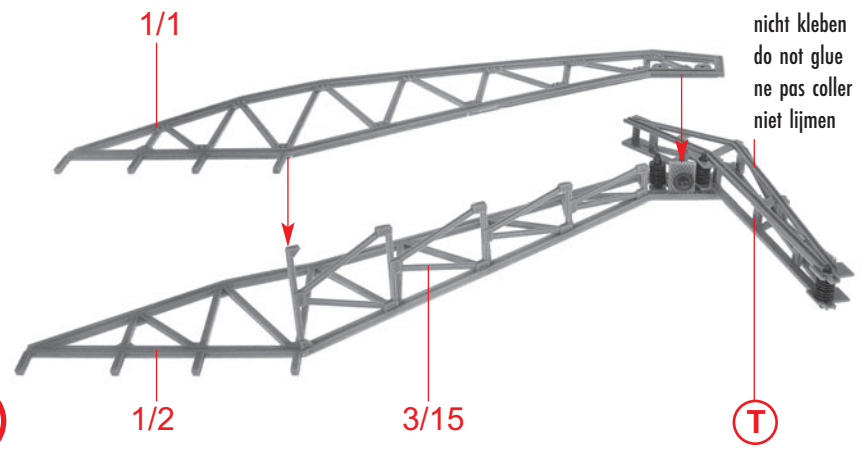

Variante I, II, III



Variante IV

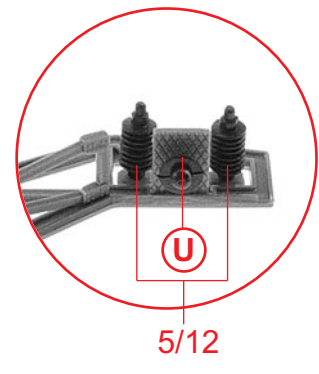

10 Variante I

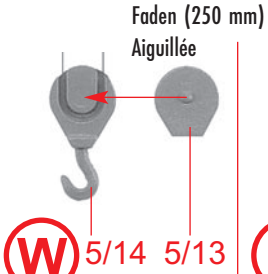

Variante II

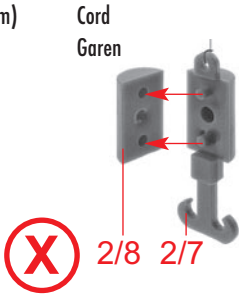

Variante III + IV

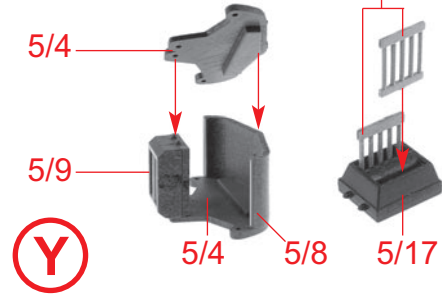

Faden (4 x 250 mm)
Aiguillée

Cord
Garen

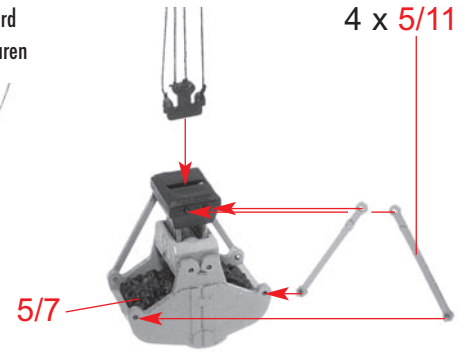
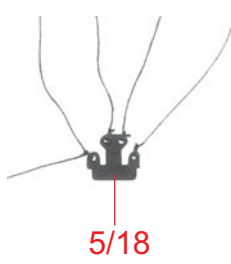

Variante I

Faden (200 mm)
Aiguillée

Cord
Garen



Variante II

Faden (200 mm)
Aiguillée

Cord
Garen



Variante III

Faden (200 mm)
Aiguillée

Cord
Garen

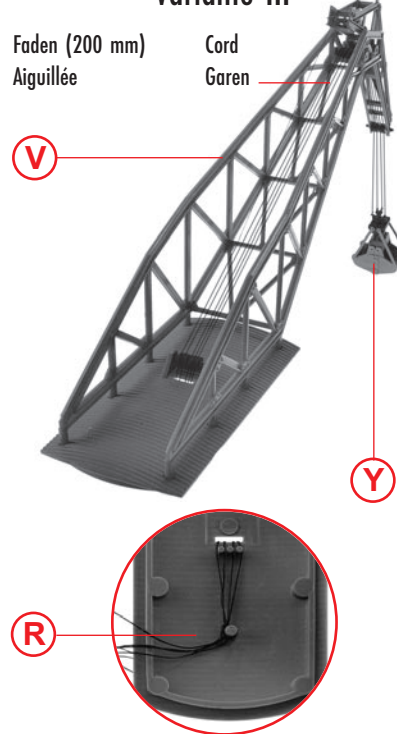

Variante IV



Z

Faden verknoten und den Knoten mit Sekundenkleber fixieren!
Nouer le fil et renforcer le noeud avec une goutte de colle rapide!

Knot the thread and fix the thread with instand cement!
Draad vastknopen en de knoop met secondenlijm fixeren!

Variante I, II, III

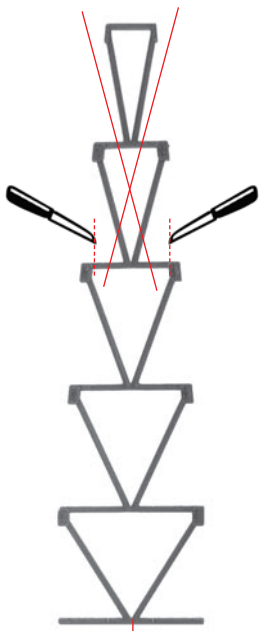

a 3/13

Variante I, II, III

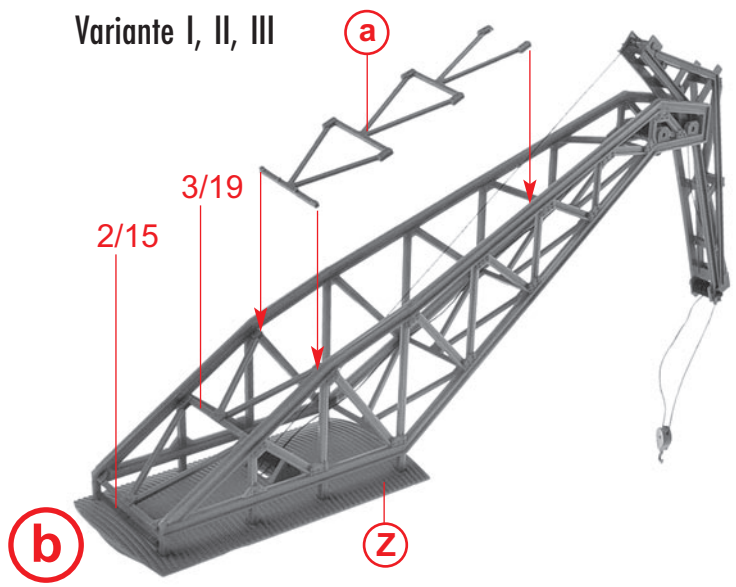

b

Variante IV

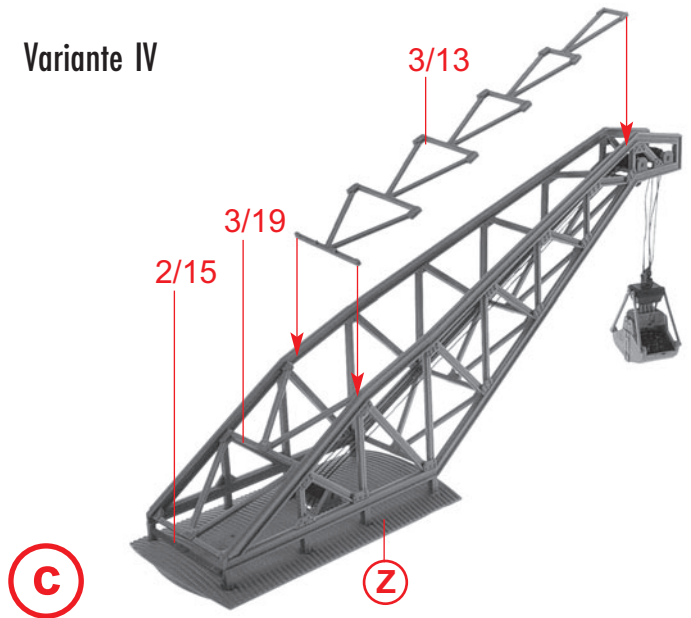

c

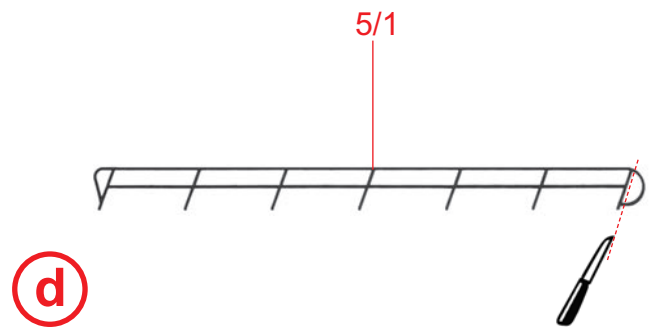

d

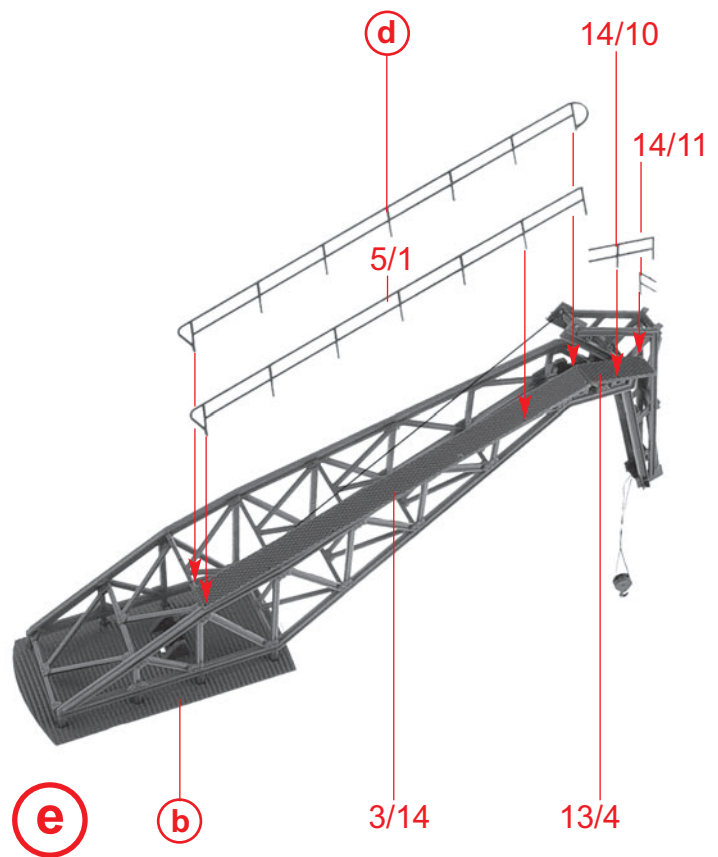

e

12

Q

e

14/13

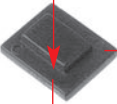
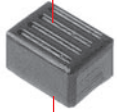

14/14

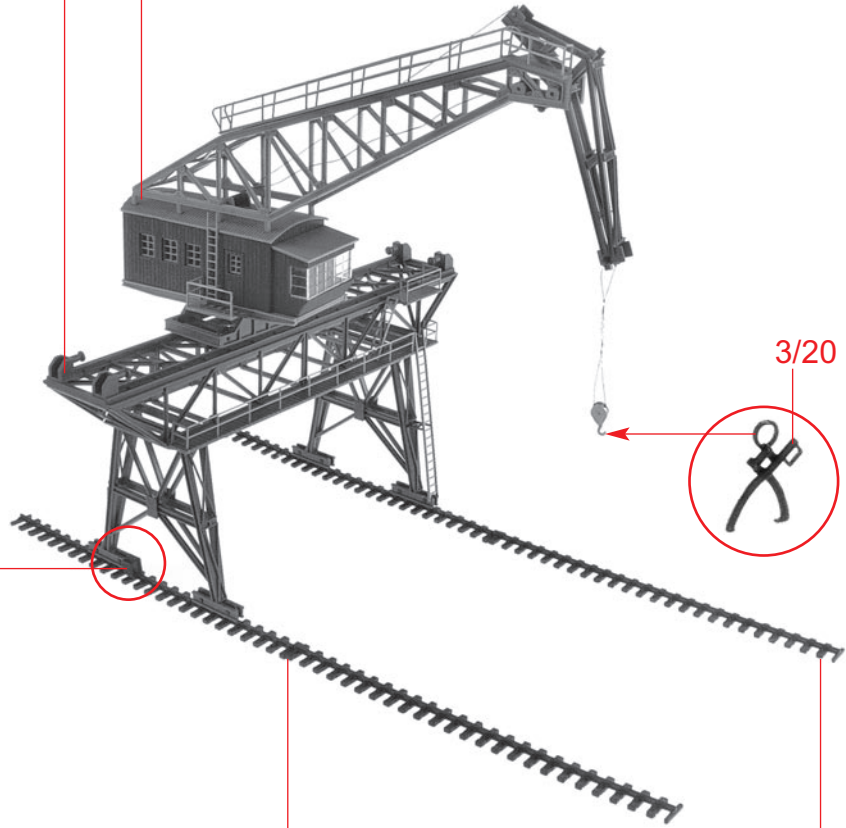

3/20

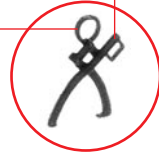

4/3

4/3

f